

# **KING COBRA/CALIBER GRASS COLLECTION SYSTEM**

## **PARTS & OPERATORS MANUAL**

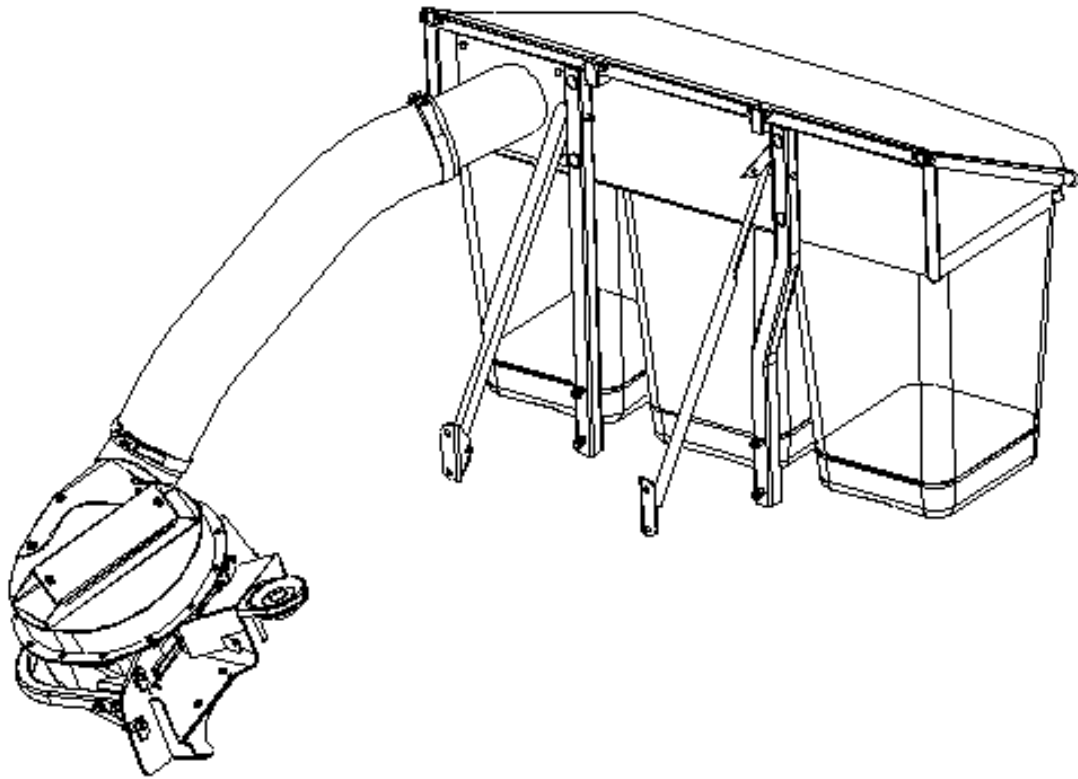

### **GRASS CATCHER W/WEIGHTS:**

**52" 542128**

**60" 542129**

### **TUBE KITS:**

**52" – 542119**

**60" – 542120**

### **BLOWER KITS:**

**5101002**

**5101003**



---

**WORLDLAWN POWER EQUIPMENT**

**401 COMMERCE STREET**

**BEATRICE, NE 68310**

**800-267-4255**

**FAX – 402-223-4103**

---

## OPERATORS MANUAL

Before operating the catcher assembly, read this manual in its entirety.

Keep this Owner's Manual when lent or transferred.

If this Operator's Manual is lost, damaged or illegible, replace it immediately. Replacements may be ordered through our sales department or our dealers. If additional information is needed, contact our sales department or a dealer. Always give the model number and serial number for the mower and the bagger. To improve the quality, performance and security we may make changes to our products.

### **WARNING**

#### **POTENTIAL HAZARD**

- This product is a piece of power equipment.

#### **WHAT CAN HAPPEN**

- Failure to follow safe operating practices can result in serious operator injury or even death.

#### **HOW TO AVOID THE HAZARD**

- Keep all shields, guards and safety devices (especially the grass discharge system) in place and in proper working condition.
- Stop machine and wait for all moving parts to stop, remove spark plug wires or remove key before adjusting, servicing, or performing maintenance.
- If mower deck becomes clogged, stop machine and wait for all moving parts to stop. Remove spark plug wire or remove key before cleaning blockage.
- Keep hands, feet, and clothing away from power driven parts.
- Keep others off mower.

---

---

## Contents

<b>SAFETY</b> .....	6
<b>SAFETY ALERT SYMBOL</b> .....	6
<b>SAFETY AND INSTRUCTION DECALS</b> .....	6
<b>INSTALLING GRASS COLLECTION SYSTEM</b> .....	7
Unpacking .....	7
Install Drive Pulley.....	7
Install the grass discharging system.....	8
Install Grass Catching System .....	8
Bag Position.....	10
Installing Belt Cover .....	10
Install Blower Tube.....	10
Install Weights .....	10
<b>OPERATION</b> .....	11
Controls.....	11
Emptying the Grass Bags .....	11
Cleaning Obstruction from the Bagger System.....	12
Transporting Machines .....	12
Operating Tips .....	12
<b>MAINTENANCE &amp; ADJUSTMENT</b> .....	13
Recommended Maintenance Schedule .....	13
Clean the debris.....	13
Replace the belt .....	13
Replace the bag .....	13
<b>ADJUSTMENT</b> .....	14
<b>TROUBLESHOOTING</b> .....	15
<b>PARTS CATALOG</b> .....	16
<b>CATCHER</b> .....	16
<b>BLOWER ASSEMBLY</b> .....	18
<b>DISCHARGE CHUTE ASSEMBLY</b> .....	21
<b>GRASS BAG ASSEMBLY</b> .....	24
<b>HOOD ASSEMBLY</b> .....	25

---

## SAFETY

The following list contains safety information specific to **WORL DLAWN** products and other safety information you must know.

- a) Read the instructions carefully. Become familiar with the safe operation of the equipment, operator controls, and safety signs.
- b) All operators need to be trained before operating this unit.
- c) Never let children or untrained people operate the equipment without proper instruction.
- d) Keep everyone, especially children and pets, away from the area of operation. Remember that the operator or user is responsible for accidents or hazards occurring to other people or their property.
- e) Do not use a grass catcher on steep slopes. A heavy grass catcher could cause loss of control or overturn the machine.
- f) Keep all movement on slopes slow and gradual. Do not make sudden changes in speed, direction or turning.
- g) The grass catcher can obstruct the view to the rear. Use extra care when operating in reverse.
- h) Keep hands and feet away from moving parts. Do not make adjustments with the engine running.
- i) Do not leave grass in grass catcher for extended periods of time.
- j) Grass catcher components are subject to wear, damage and deterioration, which could expose moving parts or allow object to be thrown. Frequently check components and replace with manufacturer's recommended parts, when necessary.
- k) Stop the engine before removing the grass catcher or unclogging the chute.

## SAFETY AND INSTRUCTION DECALS

## SAFETY ALERT SYMBOL

This symbol means: **ATTENTION! BECOME ALERT! YOUR SAFETY IS INVOLVED!**



The safety alert symbol appears above information which alerts you to unsafe actions or situations and will be followed by the word **DANGER, WARNING, or CAUTION.**

 **DANGER:** White lettering/Red background.

Indicates an imminently hazardous situation which, if not avoided, will result in death or serious injury.

 **WARNING:** Black letters on orange background.

Indicates a potentially hazardous situation which, if not avoided, could result in death or serious injury.

 **CAUTION:** Black letters on yellow background.

Indicates a potentially hazardous situation which, if not avoided, may result in minor or moderate injury. It may also be used to alert against unsafe practices

# NO STEP

8304



8045



8350

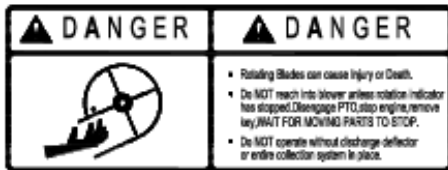

8351



8352

## INSTALLING GRASS COLLECTION SYSTEM

**Note:** The part numbers in the following assembly procedures are consistent with those in the parts catalog.

### Unpacking

- Open Crate.
- Remove loose parts (i.e., Operator's manual, etc.) from crate.
- Remove unit from crate, check crate thoroughly for loose parts.

### Install Drive Pulley

- a) Remove the side discharge chute, bushing, and belt cover (FIG 1) from the mower deck. **Note:** Keep the parts shown in broken line in a bag for later use.

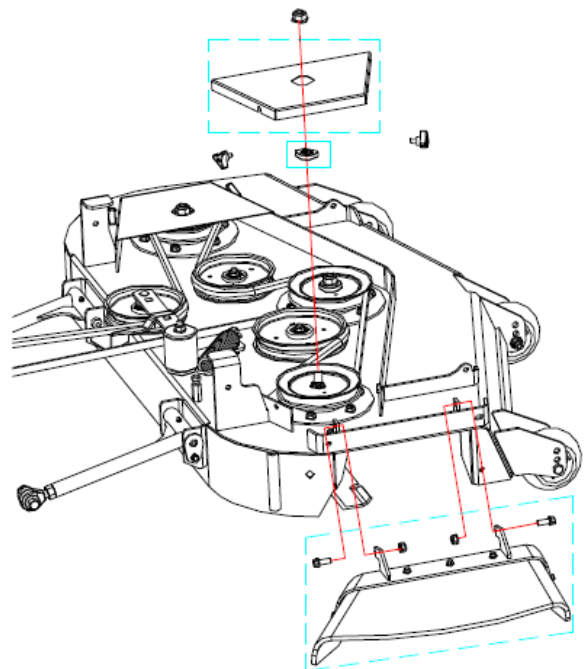

FIG 1

b) Install Drive Pulley (FIG 2) using existing hardware

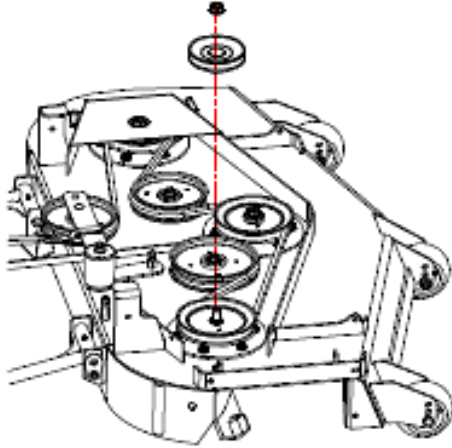

FIG 2

Note: Part no. 6 is equipped with the ZTR mower. Torque no. 6 to 156-163N m

**Install the grass discharging system**

a) Install the grass discharging system

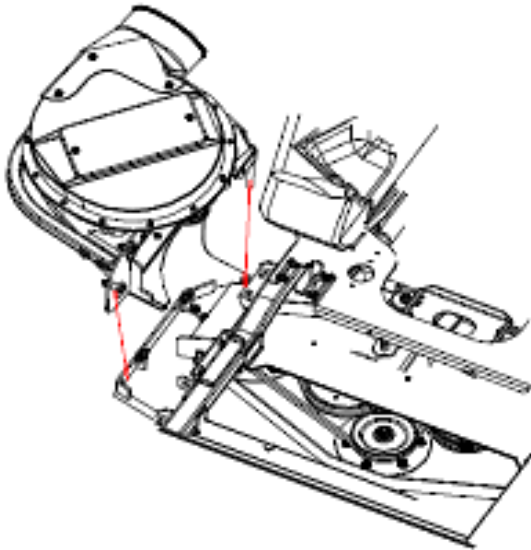

FIG 3

b) Install the tension assembly arm and belt

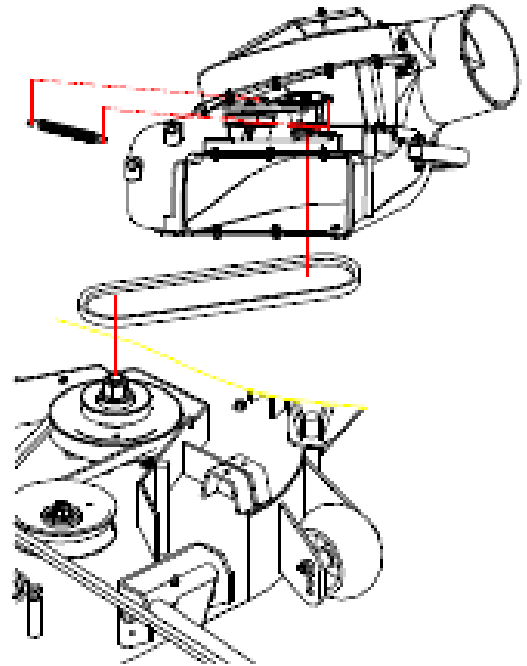
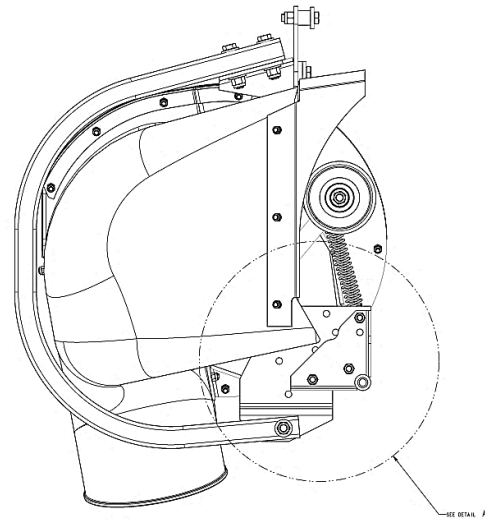
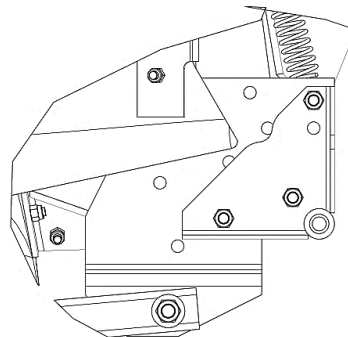

Fig 4

a) Proper Axle Pin attachment locations:



48" Bolt Pattern:





52" Bolt Pattern:

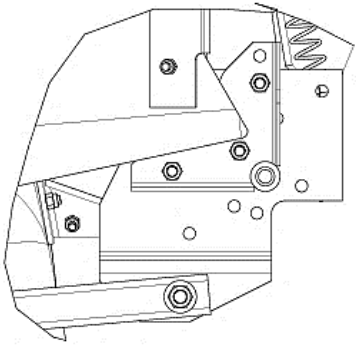

60" Bolt Pattern:

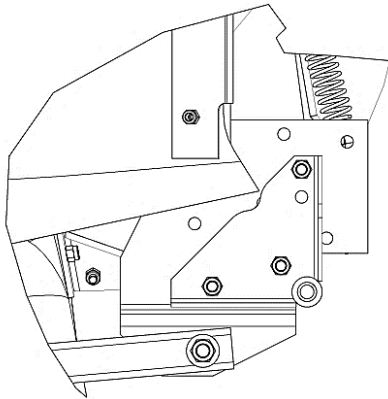

Install Grass Catcher System

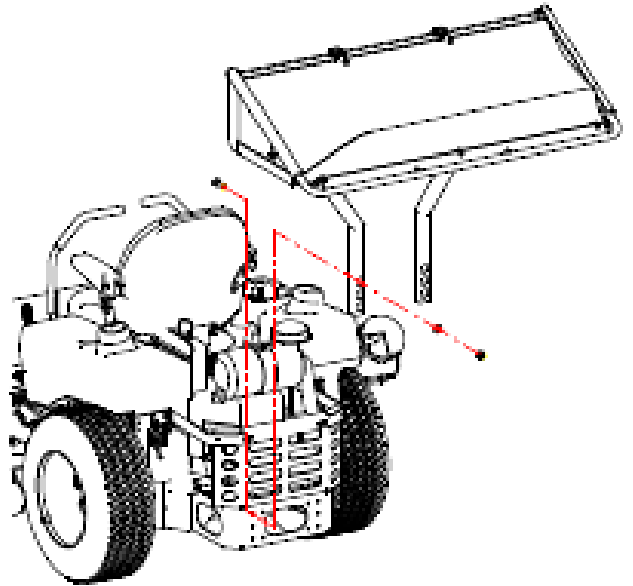

FIG 6

### Install Grass Catching System

a) Install the RH and LH frame

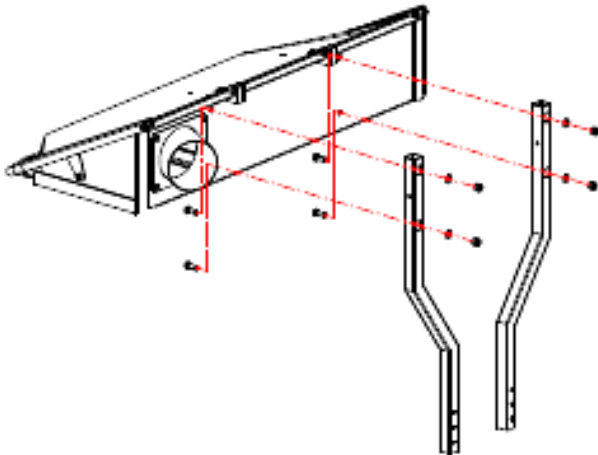
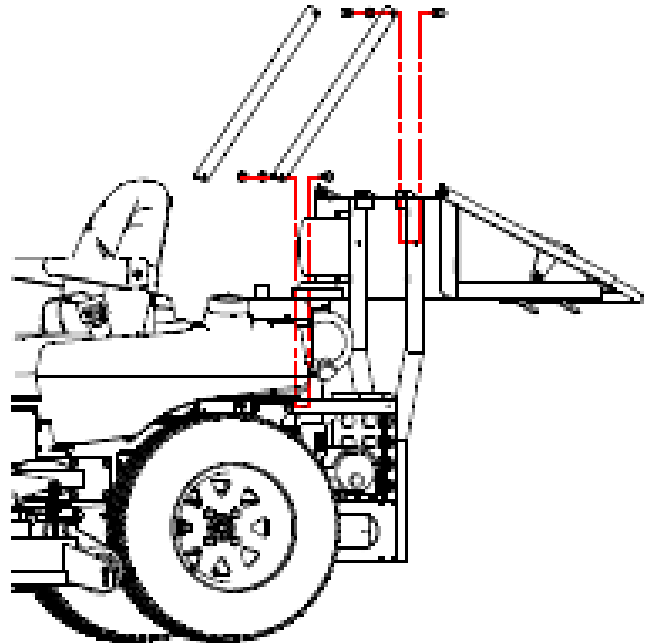

FIG 5

Install grass catcher tubes as shown above  
Spacer (A) may need to be placed inside of  
frame to increase clearance between tube &  
ROPS pocket.

b) Install the Frame Support Angle



## Bag Position

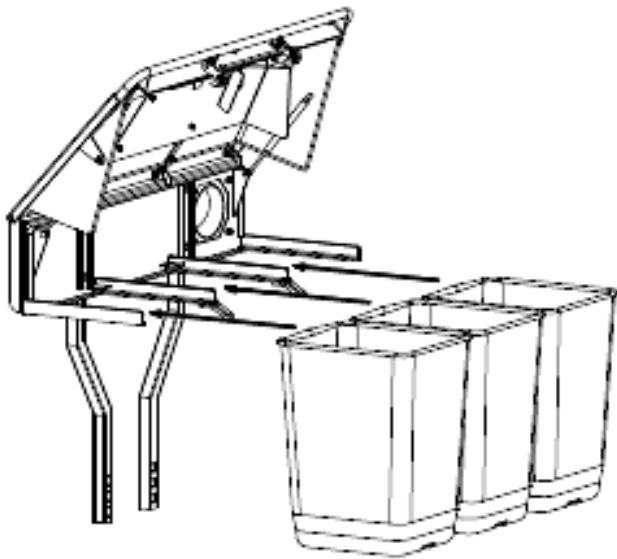

FIG 8

## Installing Belt Cover

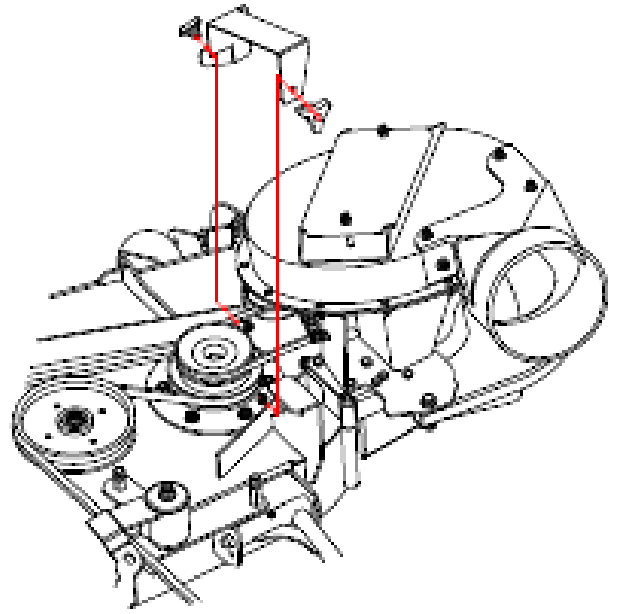

FIG 9

## Install Blower Tube

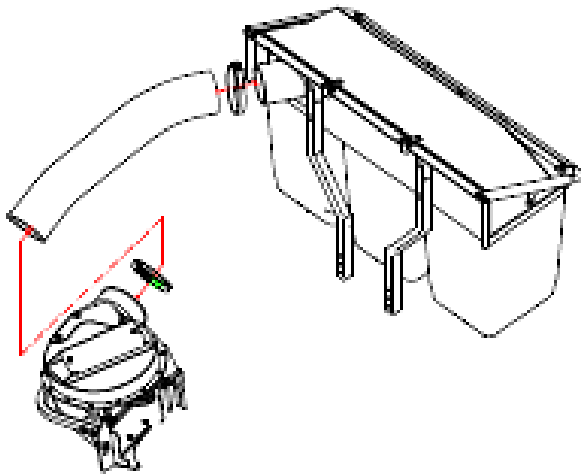

FIG 10

## Install Weights

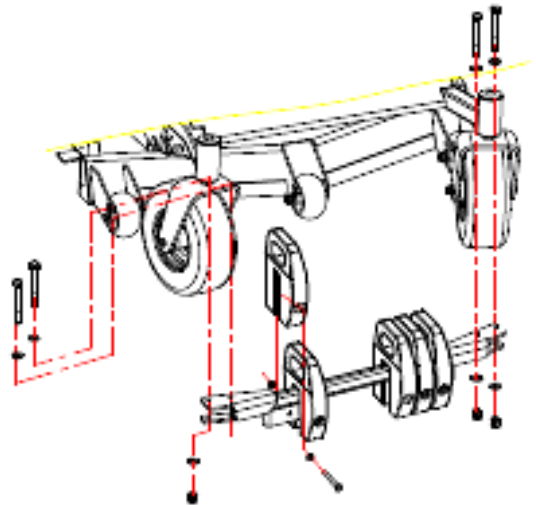

FIG 11

## OPERATION

### Controls

- 1) Familiarize yourself with all controls before operating the mower.
- 2) Keep a safe working area.
- 3) Always remove the ignition key and set the parking brake when leaving the machine unattended, even if just for a few minutes.
- 4) Children or bystanders may be injured if they move or attempt to operate the mower when it is unattended.

#### **WARNING**

##### **POTENTIAL HAZARD**

- Not being aware of working area.
- Not shutting off engine and setting the parking brake while it is unattended.
- Children or bystanders attempt to operate the mower.

##### **WHAT CAN HAPPEN**

- Bystanders may be injured while moving forward, backward or turning around.
- Children or bystanders may be injured if they move or attempt to operate the mower while it is unattended.

##### **HOW TO AVOID THE HAZARD**

- Keep a safe working area.
- Always remove the ignition key and set the parking brake when leaving the machine unattended, even if just for a few minutes.
- Children or bystanders are not allowed to operate.

### Emptying the Grass Bags

**Grass bags are heavy when full. Be careful when lifting or handling a grass bag that is full.**

- 1) Disengage the PTO, set the parking brake, and chock or block the tires if on a slope.
- 2) Unlatch the bagger latch, and open the bagger hood.
- 3) Compress the debris into the bags. With both hands, lift up on the bag and unhook it from the bagger bracket.
- 4) Grasp the handle on the bottom of the bag and tip it over to empty the bag.
- 5) Clean off the grass from the bracket, especially the notch in the bracket.
- 6) Replace bag by sliding it completely into proper position.

#### **WARNING**

##### **POTENTIAL HAZARD**

- Opening the hood as engine is running
- Dumping grass on a slope.
- Grass bag is heavy when full
- Grass buildup in the notch of the bagger bracket.

##### **WHAT CAN HAPPEN**

- Opening the hood while engine is running, may cause injury due to flying debris.
- Even with park brake set unit may slip on slope due to weight of full bags
- You will be hurt when lifting the fully loaded bag.
- The bag is not fully in position and the hood cannot be latched

##### **HOW TO AVOID THE HAZARD**

- Turn off the engine, waiting for all moving parts to stop before leaving the operating position.
- Using a stick or similar object to obstruct the wheel on a slope.
- Lift the bag using both hands
- Clean grass from the bracket, especially the notch in the bagger bracket.

## Cleaning Obstruction from the Bagger System

- 1) Disengage the PTO and set the parking brake.
- 2) Turn off the engine, remove the key, and wait for all moving parts to stop.
- 3) Empty the bags.
- 4) Unlatch the lower tube.
- 5) Use a long object, not your hands, to remove an obstruction.

### CAUTION

#### POTENTIAL HAZARD

· Raising the rear of the unit relying solely on jacks could be dangerous.

#### WHAT CAN HAPPEN

· The jacks may not be enough support or may malfunction allowing the unit to fall, which could cause injury.

#### HOW TO AVOID THE HAZARD

· DO NOT rely solely on the jacks for support. Use adequate jack stands or equivalent support.

## Transporting Machines

Do not leave grass or debris in the bagger while transporting the machine

### WARNING

#### POTENTIAL HAZARD

· Leave grass or debris in the bagger while transporting the machine.

#### WHAT CAN HAPPEN

· Transporting the machine with grass or debris in the bagger can damage the machine.

#### HOW TO AVOID THE HAZARD

· Do not leave grass or debris in the bagger while transporting the machine.

## Operating Tips

- 1) Remember that the machine is longer and wider with this attachment installed. By turning too sharply in confined places you may damage the attachment or the other property.
- 2) Always trim with the left side of the mower
- 3) Cut the grass often, especially when it grows rapidly. For best cutting appearance,

be sure to slightly overlap the mower into the previously cut area. This helps reduce the load on the engine and reduce the chance of plugging the blower assembly and tubes.

### CAUTION

#### POTENTIAL HAZARD

· Cutting tall grass, and moving forward too fast.

#### WHAT CAN HAPPEN

· Plug the blower assembly

#### HOW TO AVOID THE HAZARD

· When the grass is too long, be sure cut it several times and move slowly.

- 4) If the grass is ever allowed to grow longer than normal or if it contains a high degree of moisture raise the cutting height higher than usual and cut and bag the grass at that setting. Then cut and bag the grass again, using the lower normal setting. Excessively long grass is heavy and may not be propelled completely into the bagger.
- 5) If possible, always try to cut grass when it is dry. Wet grass can cause plugging.
- 6) To avoid plugging the bagging system, reduce ground speed and mow the grass at a high height of cut, then lower the mower to your normal cutting height and repeat the bagging process.
- 7) As you are bagging, small amounts of grass clipping normally blow out the front of the mower. An excessive amount of clipping blow-out indicates that the bagger is full or the tube is plugged.
- 8) Always lift the deck to the highest position when loading the machine on trailer or ascending/descending a curb.

## MAINTENANCE & ADJUSTMENT

### **WARNING**

#### POTENTIAL HAZARD

- Engine is started when making the adjustment.

#### WHAT CAN HAPPEN

- May result in serious injury, death.

#### HOW TO AVOID THE HAZARD

- Before adjustment, remove the key.

### **WARNING**

#### POTENTIAL HAZARD

- Engine is overheating.

#### WHAT CAN HAPPEN

- Severe burns can occur on contact.

#### HOW TO AVOID THE HAZARD

- Allow engine parts, especially the muffler, to cool before touching.

### Recommended Maintenance Schedule

Maintenance Service Interval	Maintenance Schedule Interval
After the first 6 operating hours	<ul style="list-style-type: none"> <li>Inspect the belt</li> </ul>
Before each use or daily	<ul style="list-style-type: none"> <li>Clean the blower assembly</li> <li>Clean the bagger system</li> <li>Clean the bags</li> </ul>
Every 25 hours	<ul style="list-style-type: none"> <li>Inspect the belt</li> </ul>

### Clean the debris

Maintenance interval: Daily

Turn off the engine, remove the key, and wait for all moving parts to stop

- 1) Raise the front of the unit and support it with jack stands or equivalent support to the transportation position

### **CAUTION**

#### POTENTIAL HAZARD

- Raising the front of the unit relying solely on jacks could be dangerous.

#### WHAT CAN HAPPEN

- The jacks may not be enough support or may malfunction allowing the unit to fall, which could cause injury.

#### HOW TO AVOID THE HAZARD

- DO NOT rely solely on the jacks for support. Use adequate jack stands or equivalent support.

- 2) Clean the debris from underside of the mower and in the blower assembly.
- 3) Wash the inside and outside of the bagger hood, bags, tube and the underside of the mower.
- 4) After washing all the parts, let them dry thoroughly and re-install.
- 5) With all parts installed, start and run the machine for a minute to assist in drying.

### Replace the belt

- 1) Disengage to PTO, move the motion control levers to the neutral locked position, and set the parking brake.
- 2) Stop the engine, remove the key and wait for all moving parts to stop before leaving the operating position.
- 3) Remove the belt cover and relieve the belt tension
- 4) Replace the new belt.
- 5) Adjust the belt pulley and the reinstall the belt cover.

### Replace the bag

- 1) Disengage the PTO, move the motion control levers to the neutral locked position and set the parking brake.
- 2) Stop the engine, remove the key and wait for all moving parts to stop before leaving the operating position.
- 3) Unlock the bagger frame
- 4) Slide out the bag along the bagger frame locking position.
- 5) Replace with new bag.

---

## ADJUSTMENT

### Deflector Adjustment

**Deflector can fill the three bags evenly if adjusted properly.**

- 1) Empty the three bags
- 2) Cut grass for approximately three minutes
- 3) Disengage the PTO, move the motion control levers to the neutral locked position and set the parking brake.
- 4) Stop the engine, remove the key and wait for all moving parts to stop before leaving the operating position.
- 5) Open the hood, check the level of fill in the three bags
- 6) Adjust the deflector position according to the grass levels in the bag.
- 7) Repeat procedure 2-6 times until the grass level in the three bags are even.

NOTE: The catcher fill of the three bags can't be 100% the same.

## STORAGE

- a) Clean the bagger attachment. Refer to cleaning the bagger
- b) Inspect the bagger attachment for damage.
- c) Make sure the bags are empty and thoroughly dry.
- d) Store the machine in a clean, dry place, out of direct sunlight. If you must store the machine outside, cover it with a weatherproof cover. This protects the plastic parts and extends the life of the machine.

## TROUBLESHOOTING

Problem	Possible Cause	Corrective Action
Abnormal vibration	<ul style="list-style-type: none"> <li>• Cutting blades are bent or unbalanced</li> <li>• Loose blower pulley or pulley assembly</li> </ul>	<ul style="list-style-type: none"> <li>• Install new cutting blade</li> <li>• Tighten the pulley</li> </ul>
Reduced bagging performance	<ul style="list-style-type: none"> <li>• Low engine speed</li> <li>• Plugged screen in bagger hood</li> <li>• Loose bagger belt</li> <li>• Full bags</li> </ul>	<ul style="list-style-type: none"> <li>• Always operate the bagger at full throttle</li> <li>• Remove debris, leaves or grass clippings from the screen</li> <li>• Replace the bagger belt</li> <li>• Empty the hopper</li> </ul>
Blower and tubes plug too frequently	<ul style="list-style-type: none"> <li>• Bags are too full</li> <li>• Low engine speed</li> <li>• Grass is too wet</li> <li>• Grass is too long</li> <li>• Ground speed is too fast</li> <li>• Worn bagger belt</li> <li>• Loose bagger belt</li> </ul>	<ul style="list-style-type: none"> <li>• Dump more frequently</li> <li>• Always operate the bagger at full throttle</li> <li>• Cut grass when it is dry</li> <li>• Cut the grass several times</li> <li>• Drive slower at full throttle</li> <li>• Replace belt</li> <li>• Adjust the pulley, tighten belts</li> </ul>
Debris blowout	<ul style="list-style-type: none"> <li>• Bags are too full</li> <li>• Plug in the bagger system</li> <li>• Ground speed is too fast</li> </ul>	<ul style="list-style-type: none"> <li>• Dump more frequently</li> <li>• Clean the bagger system</li> <li>• Drive slower at full throttle</li> </ul>
Impeller can't rotate freely	<ul style="list-style-type: none"> <li>• Plug in the blower system</li> <li>• Worn impeller</li> </ul>	<ul style="list-style-type: none"> <li>• Clean the blower system</li> <li>• Contact dealer to replace</li> </ul>



# PARTS CATALOG

## CATCHER

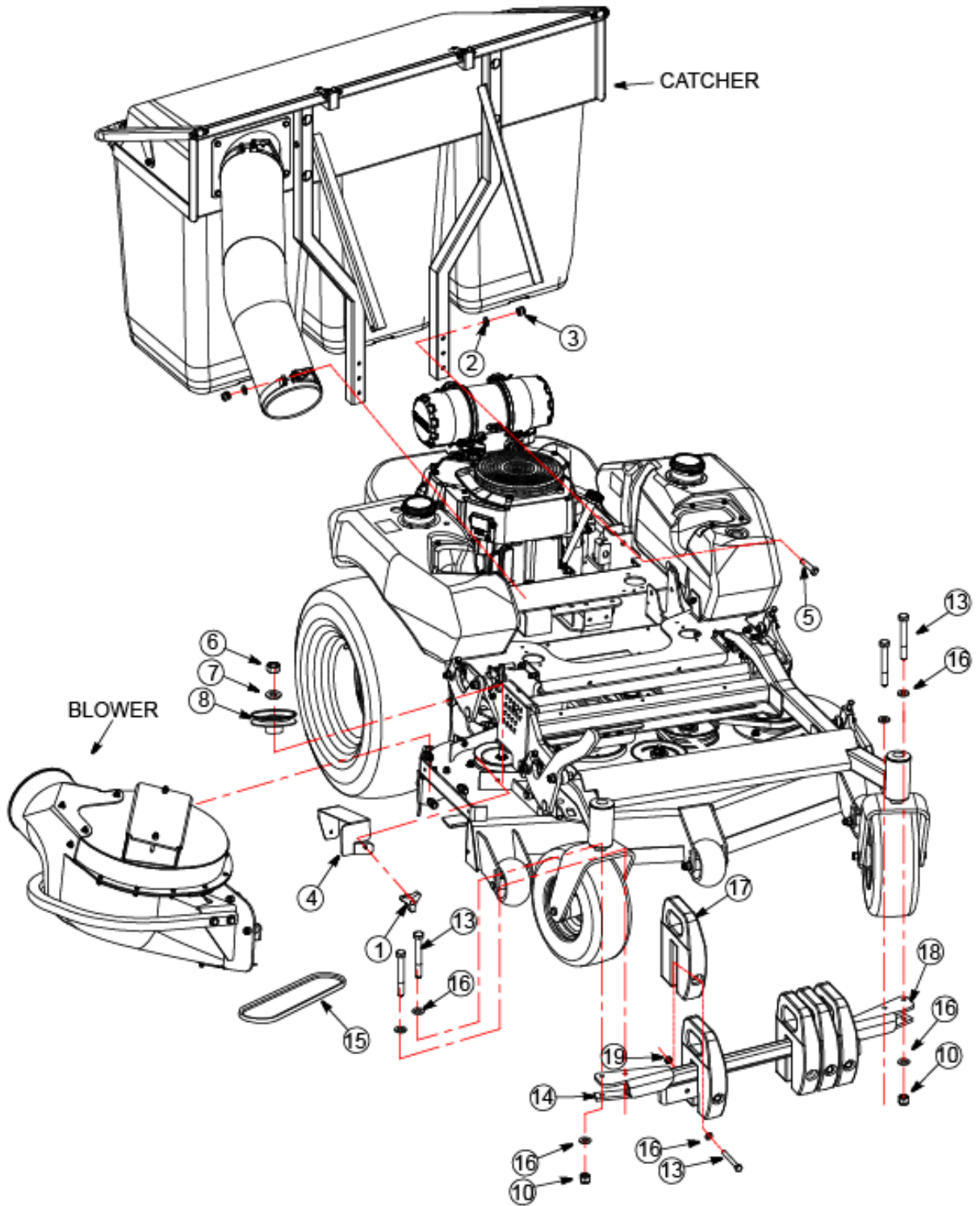



**CATCHER**

<b>ITEM</b>	<b>PART NO.</b>	<b>DESCRIPTION</b>
1	3302190	KNOB, 3-PRONGED W/STUD
2	B97.1-8	WASHER 8
3	B6182-8	NUT, NYLOC M8
4	5101012	52 BELT SHIELD
	5101013	60 BELT SHIELD
5	B5783-820	HEX HD BOLT M8 X 20
6	B6171-20	NUT M20 X 1.5
7	5201048	WASHER
8	5101106	52" BLOWER DRIVE PULLEY
	5101110	60" BLOWER DRIVE PULLEY
9	B5787-1025	HEX HD BOLT M10- X 25
10	B6183.1-10	LOCKNUT M10
11	B5787-825	HEX HD BOLT M8 X 25
12	B93-8	SPLIT LOCK WASHER M8
13	B5782-1090	BOLT M10 X 90
14	5101252	MOUNTING PLATE
15	543451	52" BELT
	543452	60" BELT
16	B97.1-10	FLAT WASHER M10
17	5101251	WEIGHTS
18	5101255	WEIGHT FRAME WELDMENT 52"
	5101265	WEIGHT FRAME WELDMENT 60"
19	B13687-10	HEX HD BOLT M10

# BLOWER ASSEMBLY

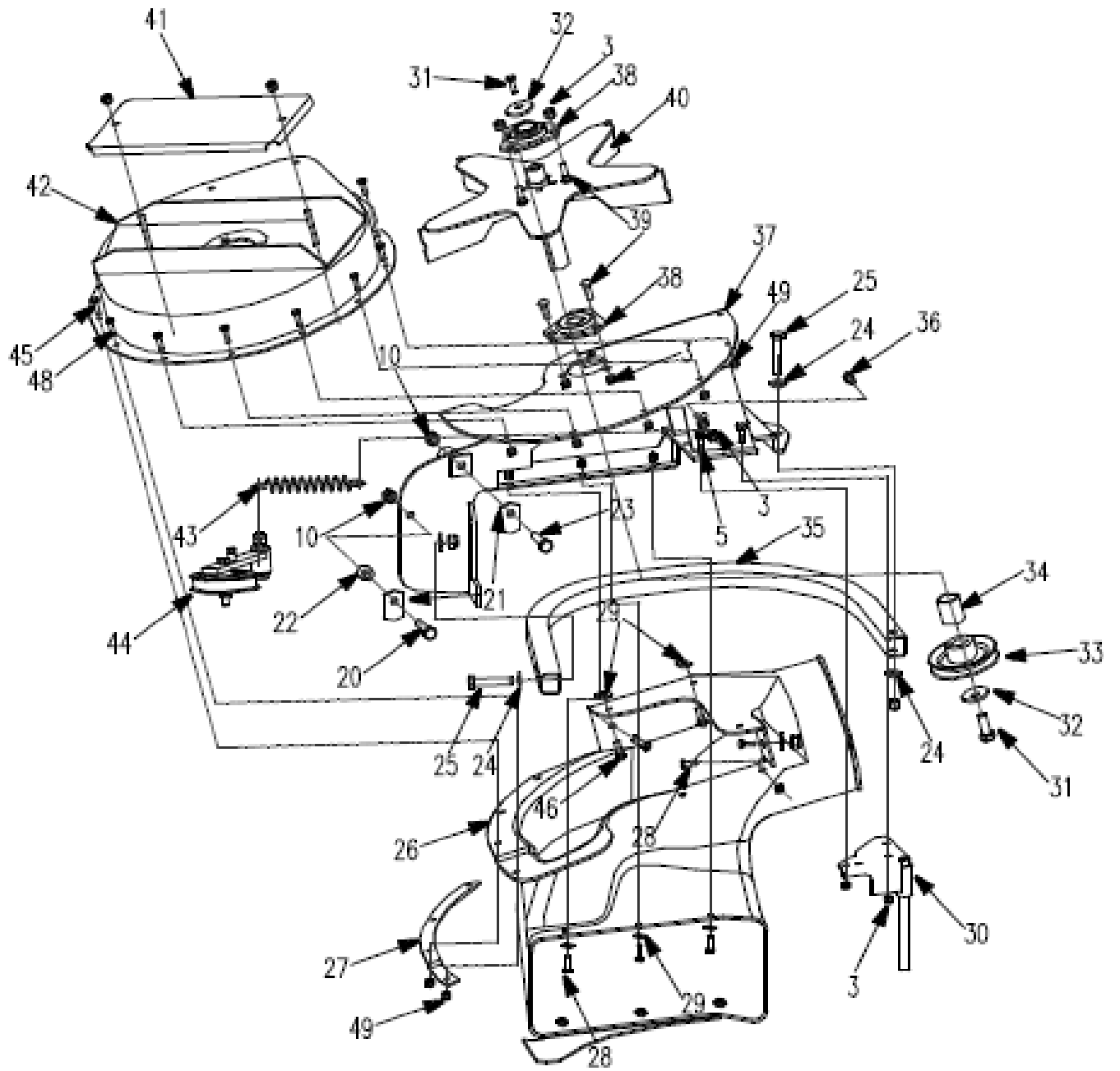

**BLOWER ASSEMBLY**

<b>ITEM</b>	<b>PART NO.</b>	<b>DESCRIPTION</b>
10	B6182-10	NUT M10
3	B6182-8	NUT M8
5	B5783-820	BOLT M8 X 20
20	B5783-1045	BOLT M10 X 45
21	5101025	PANEL
22	5101026	BUSHING
23	B5783-1035	BOLT M10 X 35
24	3302058	WASHER 10
25	B5783-1055	BOLT M10 X 55
26	5101155	52" DISCHARGE CHUTE ASSEMBLY
	5101165	60" DISCHARGE CHUTE ASSEMBLY
27	5101027	MULCHING PLATE
28	B2672-620	SCREW M6 X 20
29	B96-6	WASHER 6
30	5101160	AXLE PIN WELDMENT
31	B5783-1230	BOLT M12 X 30
32	3302008	BELLEVILLE SPRING
33	5101135	BLADE PULLEY
34	5101023	BUSHING
35	5101022	BUMPER
36	B5783-830	BOLT M8 X 30
37	5101140	FAN COVER
38	B7810-UBPFT205	BEARING
39	B12-825	SQUARE BOLT M8 X 25
40	5101130	IMPELLER WELDING
41	5101024	COVER
42	5101120	UPPER COVER
43	5210417	TENSION SPRING
44	5101170	ASM, IDLER ARM
45	B5783-620	BOLT M6 X 20
46	B801-620	BOLT M6 X 20
48	B5783-625	BOLT M6 X 25
49	B6182-6	NUT M6

## TENSION PULLEY ASSEMBLY DRIVE BELT

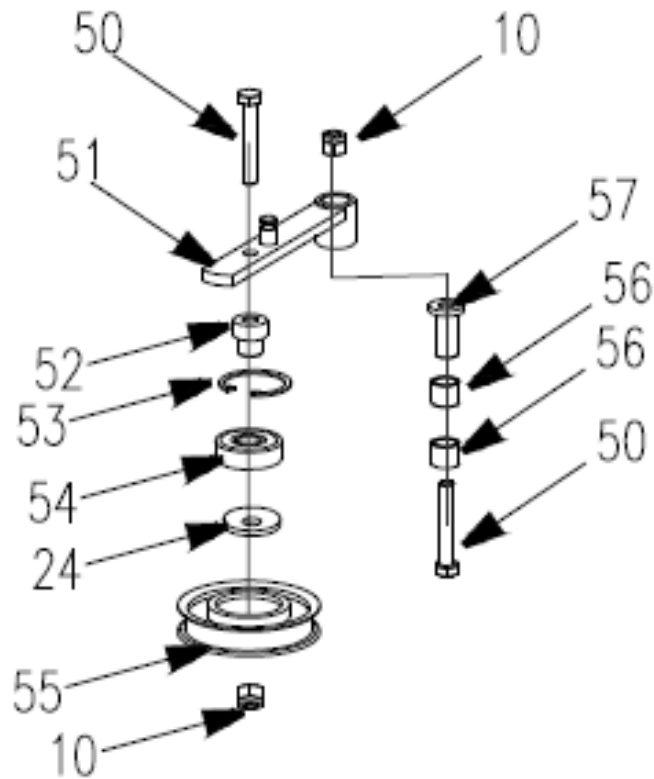

ITEM	PART NO.	DESCRIPTION
10	B6182-10	NUT M10
24	3302058	WASHER 10
50	B5783-1060	BOLT M10 X 60
51	5101175	TENSION ARM WELDMENT
52	5002161	TENSION PULLEY SPACER
53	B893.2-47	SPACER 47
54	B276-6303RS	BEARING 6303-2RS
55	5002175	IDLER PULLEY WELDMENT
56	B2685-162016	BEARING 16 X 20 X 16
57	5101171	BUSHING

## DISCHARGE CHUTE ASSEMBLY

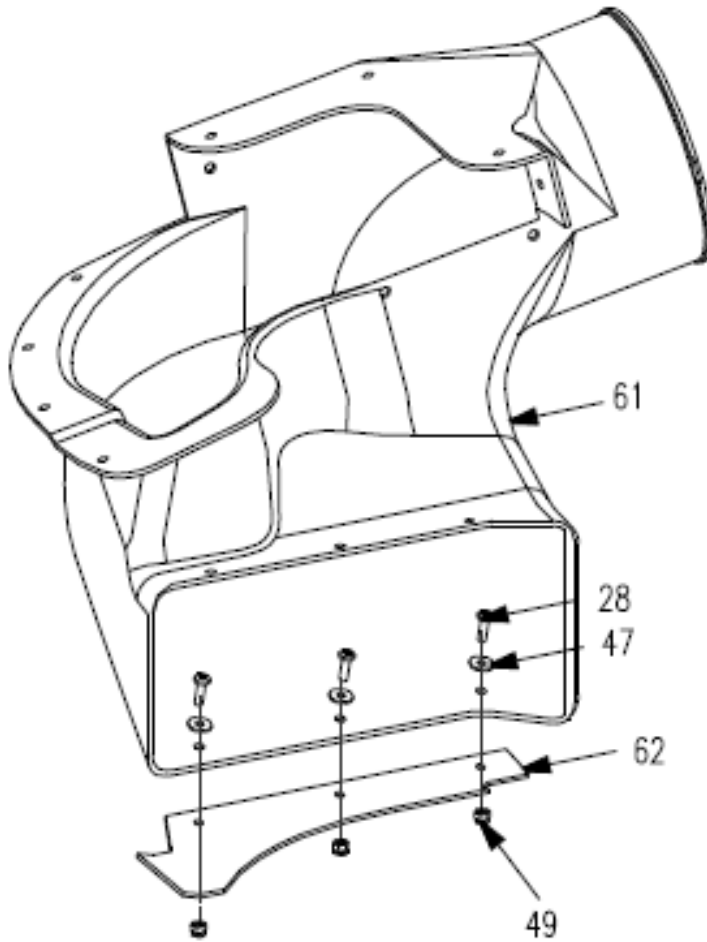

ITEM	PART NO.	DESCRIPTION
28	B2672-620	Bolt M6 x 20
29	B96-6	Washer 6
49	B6182-6	NUT M6
61	5101157	52" Discharge Chute
	5101167	60" Discharge Chute
62	5101156	Mulching Plate

# GRASS CATCHER ASSEMBLY

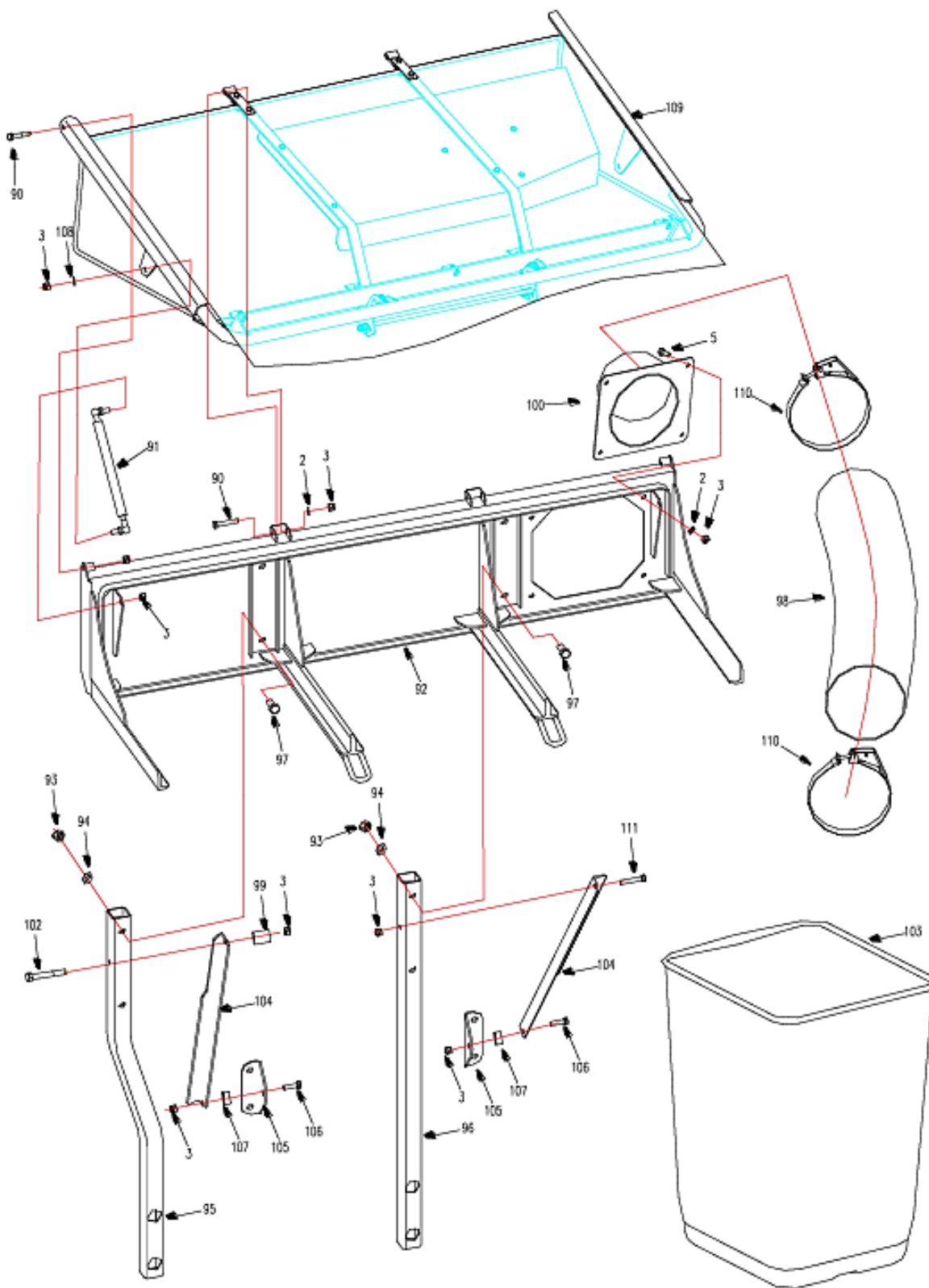

**GRASS CATCHER ASSEMBLY**

<b>ITEM</b>	<b>PART NO.</b>	<b>DESCRIPTION</b>
2	B97.1-8	WASHER 8
3	B6182-8	NUT M8
5	B5783-820	BOLT M8x20
90	B5782-845	BOLT M8x45
91	5210107	DAMPER
92	5101230	HOOD FRAME ASSEMBLY
93	B6182-12	NUT M12
94	B97.1-12	WASHER 12
95	5101202	SECURITY BAR RH FRAME
96	5101201	SECURITY BAR LH FRAME
97	B5783-1230	BOLT M12x30
98	543453	GRASS TUBE
99	5101204	SPACER
100	5101235	HOOD INLET ADAPTOR
102	B5782-890	BOLT M8x90
103	5210170	GRASS BAG
104	5101203	SHIFT ROD
105	5101206	MOUNTING PLATE
106	B5782-830	BOLT M8 X 30
107	5101205	SPACER 2
108	B96-8	WASHER 8
109	5101220	GRASS BAG PLATE
110	153048	TUBE CLAMP
111	B5782-860	BOLT M8 X 60

## GRASS BAG ASSEMBLY

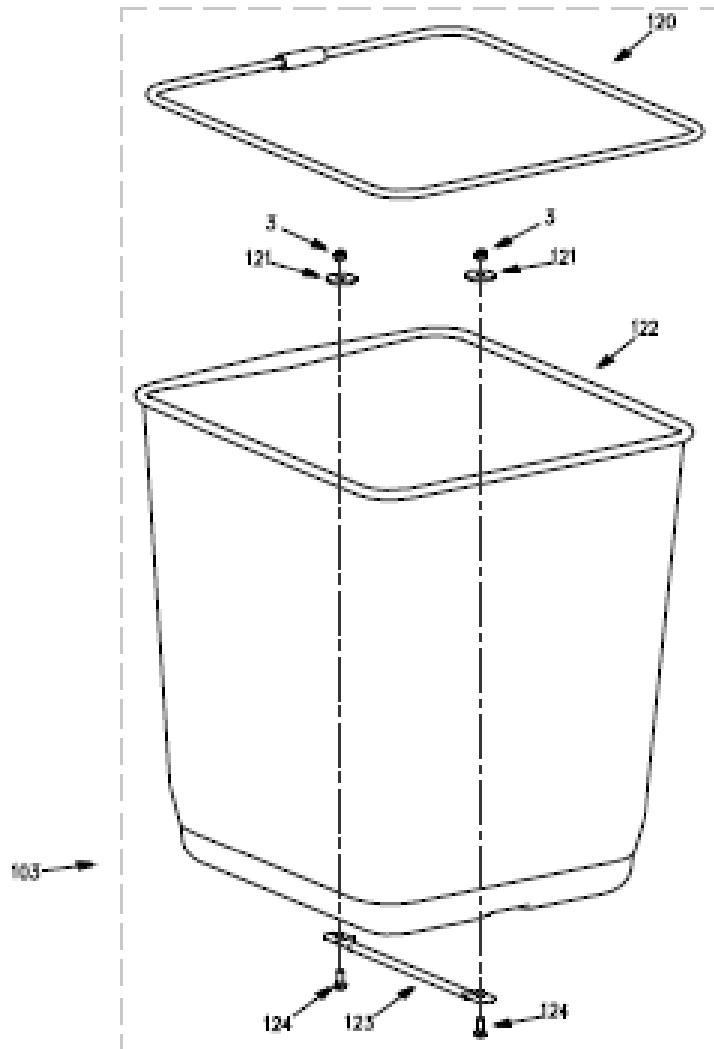

ITEM	PART NO.	DESCRIPTION
3	B6182-8	Nut M8
103	5210170	Bag Asm.
120	5210174	Bag Frame
121	5210177	Washer
122	5210178	Bag
123	5210176	Handle
124	B12-620	Bolt M6×20



## HOOD ASSEMBLY

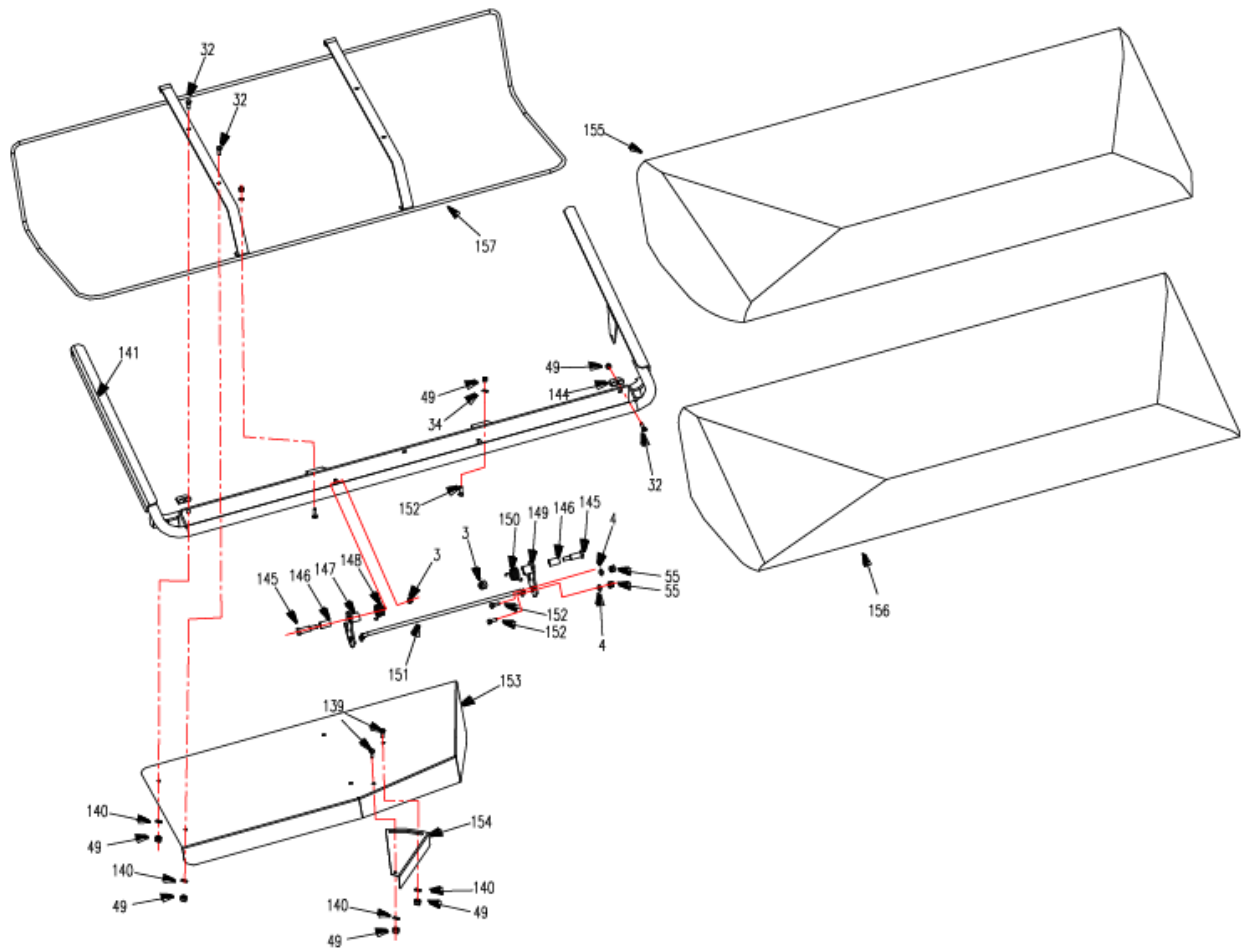

ITEM	PART NO.	DESCRIPTION
3	B6182-8	NUT M8
49	B6182-6	NUT M6
139	B5783-616	BOLT M6 X 16
140	B97.1-6	WASHER 6
141	5101221	HOOD FRAME ASSEMBLY
144	5210106	COVER HOLD-DOWN PLATE
145	2806055	PLATE
146	5210188	CLEVIS PIN
147	5210182	NYLON BUSHING
148	5210184	DECK HOOK WELDMENT – RH
149	5210180	TORSION SPRING, RH
150	5210183	LATCH – RH
151	5210187	TORSION SPRING – LH
152	B5783-618	HANDLE
153	5210210	BOLT M6 X 18
154	5210212	FIXED DEFLECTOR PLATE
155	5210154	DUST COVER
156	5101210	INNER DUST COVER
157	5101225	BAG FRAME W/LATCH





