

# Operator's Manual



**WORLDLAWN®**

**WYZ 52/60**

**Zero Turn Mower**



Worldlawn Power Equipment, Inc.

422 Turnbull Canyon Road, City of Industry, CA 91744

Toll Free Number: 1-866-9-Mowers (1-866-966-9377)



## OPERATOR'S MANUAL

This manual contains assembly, operating, maintenance, adjustment and safety instructions for your WYZ52/ WYZ60 lawn mower.

Before operating your mower, carefully read this manual in its entirety.

By following the operating, maintenance, adjustment and safety instructions, you will prolong the life of your mower, maintain its maximum efficiency and promote safe operation.

Keep this mower Owner's Manual when lent or transferred.

Should this mower Operator's Manual become lost, damaged or illegible, replace immediately, replacements may be ordered through our sales department. If additional information is needed, contact our sales department or a dealer. Always give the model number and serial number.

To improve the quality, maneuverability and security of our products, we may make changes of our products. Sorry for the inconvenience if you find the products in hand a bit different from the manual.



### **POTENTIAL HAZARD**

- This product is a piece of power equipment

### **WHAT CAN HAPPEN**

- Failure to follow safe operating practices can result in serious operator injury or even death

### **HOW TO AVIOD THE HAZARD**

- Keep all shields, guards and safety devices (especially the grass discharge system) in place and in proper working condition.
- Stop machine and wait for all moving parts to stop ,remove spark plug wires or remove key before adjusting ,servicing, or performing maintenance.,
- If mower deck becomes clogged, stop machine and wait for all moving parts to stop. Remove spark plug wire or remove key before cleaning blockage .
- Keep hands ,feet ,and clothing away from power driven parts ,
- Keep others off mower.



### **POTENTIAL HAZARD**

- Gasoline is harmful or fatal if swallowed.Long-term exposure to vapors have been known to caused cancer in laboratory animals .

### **WHAT CAN HAPPEN**

- Failure to use caution may cause serious injury or illness,

### **HOW TO AVIOD THE HAZARD**

- Avoid prolonged breathing of vapors .
- Keep face away from nozzle and gas tank opening
- Keep away from eyes and skin.
- Never siphon by mouth .





---

## TABLE OF CONTENTS

<b>1. SAFETY</b> .....	1
1.1 Safety Alert Symbol.....	1
1.2 Training.....	1
1.3 Preparation.....	1
1.4 Operation.....	2
1.5 Maintenance & Storage.....	5
1.6 Safety Signs.....	6
<b>2. SPECIFICATIONS</b> .....	9
2.1 Model Number.....	9
2.2 Engine.....	9
2.3 Fuel System.....	9
2.4 Electrical System.....	9
2.5. Operator Controls.....	9
2.6. Seat.....	10
2.7 Hydrostatic Ground Drive System.....	10
2.8. Tires And Wheels.....	10
2.9. Cutting Deck.....	11
2.10. Dimension.....	11
2.11. Torque Requirements.....	12
<b>3. ASSEMBLY INSTRUCTIONS</b> .....	12
3.1 Uncrate Mower.....	12
3.2 Initial Instructions .....	12
3.3 Service Battery.....	14
3.4 CHECK TIRE PRESSURE.....	15
3.5 INSTALL SEAT.....	15
3.6 INSTALL MOTION CONTROL LEVERS.....	16
3.7 Position Discharge Chute.....	16
3.8 Service Engine.....	16
3.9. Service Hydraulic Oil.....	17
<b>4. OPERATION INSTRUCTIONS</b> .....	17
4.1 Controls.....	17



---

4.2	Pre-Start.....	19
4.3	Mowing.....	20
4.4	Transporting.....	21
<b>5.</b>	<b>MAINTENANCE &amp; ADJUSTMENTS.....</b>	<b>22</b>
5.1	Periodic Maintenance.....	22
5.2	ADJUSTMENTS.....	29
<b>6.</b>	<b>TROUBLE SHOOTING.....</b>	<b>33</b>
<b>7.</b>	<b>HYDRAULIC DIAGRAM.....</b>	<b>36</b>
<b>8.</b>	<b>ELECTRICAL DIAGRAM.....</b>	<b>37</b>
	WARRANTY.....	38



# 1. SAFETY

## 1.1 SAFETY ALERT SYMBOL

This **SAFETY ALERT SYMBOL**  is used both in this manual and on the machine to identify important safety messages which must be followed to avoid accidents. This symbol means:

### **ATTENTION! BECOME ALERT! YOUR SAFETY IS INVOLVED!**

The safety alert symbol appears above information which alerts you to unsafe actions or situations and will be followed by the word **DANGER, WARNING, or CAUTION.**

 **DANGER**: White lettering/Red background.

Indicates an imminently hazardous situation which, if not avoided, **WILL** result in death or serious injury.

 **WARNING**: Black lettering/Orange background.

Indicates a potentially hazardous situation which, if not avoided, **COULD** result in death or serious injury.

 **CAUTION**: Black lettering/Yellow background.

Indicates a potentially hazardous situation which, if not avoided, **MAY** result in minor or moderate injury.

## 1.2 TRAINING

1.2.1 Regard the Mower as a piece of power equipment and teach this regard to all who operate this unit.

1.2.2 Read the instructions carefully. Familiarize yourself with the controls and the proper use of the equipment.

1.2.3 Do not allow operation of this machine by untrained personnel. Never allow children, teenagers, or anyone unfamiliar with these instructions to use the mower.

1.2.4 Avoid mowing while people, especially children, or pets, are nearby. Keep in mind that the

operator or user is responsible for accidents or hazards occurring to other people or their property.

## 1.3 PREPARATION

1.3.1 Evaluate the terrain to determine what accessories and attachments are needed to properly and safely perform the job. Only use accessories and attachments approved by

### **Worldlawn Power Equipment, Inc.**

1.3.2 The use of personal protective equipments, such as (but not limited to) protection for the eyes, ears, feet, and head is recommended.



<b>POTENTIAL HAZARD</b>
· This machine produces sound levels in excess of 85 dBA at the operator's ear when in operation.
<b>WHAT CAN HAPPEN</b>
· Exposure to sound levels of 85dBA or above for extended periods of time can cause hearing loss.
<b>HOW TO AVOID THE HAZARD</b>
· Wear hearing protection when operating this machine.

1.3.3 While mowing, always wear substantial footwear and long trousers. Do not operate equipment when barefoot or when wearing open sandals.

1.3.4 Thoroughly inspect the area where the equipment is to be used and remove all stones, sticks, wires, bones, and other foreign objects which may damage the equipment or cause personal injury to operator or bystanders.

<b>POTENTIAL HAZARD</b>
· Engine exhaust contains carbon monoxide, which is an odorless deadly poison.
<b>WHAT CAN HAPPEN</b>
· Carbon monoxide can kill you.
<b>HOW TO AVOID THE HAZARD</b>
· Do not run engine indoors or in a small confined area where dangerous carbon monoxide fumes can collect.

<p><b>POTENTIAL HAZARD</b></p> <ul style="list-style-type: none"> <li>· In certain conditions gasoline is extremely flammable and highly explosive.</li> </ul>
<p><b>WHAT CAN HAPPEN</b></p> <ul style="list-style-type: none"> <li>· A fire or explosion from gasoline can burn you, others, and cause property damage.</li> </ul>
<p><b>HOW TO AVOID THE HAZARD</b></p> <ul style="list-style-type: none"> <li>· Do not smoke while refueling, and stay away from an open flame or where gasoline fumes may be ignited by spark.</li> <li>· Refuel only outdoors.</li> <li>· Store gasoline in an approved container and keep it out of the reach of children.</li> <li>· Add fuel before starting the engine. Never remove the cap of the fuel tank or add fuel when engine is running or when the engine is hot.</li> <li>· Never fill the fuel tank so that gasoline level rises above a level that is 10(mm) below the bottom of the filler neck to allow for gasoline expansion and prevent fuel spillage.</li> <li>· If fuel is spilled, <b>DO NOT</b> attempt to start the engine. Move away from the area of the spill and avoid creating any source of ignition fuel until vapors have dissipated.</li> <li>· Do not operate without entire exhaust system in place and in proper working condition.</li> </ul>

<p><b>POTENTIAL HAZARD</b></p> <ul style="list-style-type: none"> <li>· In certain conditions gasoline is extremely flammable and highly explosive.</li> </ul>
<p><b>WHAT CAN HAPPEN</b></p> <ul style="list-style-type: none"> <li>· A static charge can ignite gasoline vapors. A fire or explosion from gasoline can burn you, others, and cause property damage.</li> </ul>
<p><b>HOW TO AVOID THE HAZARD</b></p> <ul style="list-style-type: none"> <li>· Purchase and store gasoline only in an approved container.</li> </ul>

<ul style="list-style-type: none"> <li>· Always place gasoline containers on the ground away from your vehicle while filling.</li> <li>· Do not fill gasoline containers inside a vehicle or on a truck or trailer bed because interior carpets or plastic truck bed liners may insulate the container and slow the loss of any static charge.</li> <li>· When practical, remove gas-powered equipment from the truck or trailer and refuel the equipment with its wheels on the ground.</li> <li>· If this is not possible, then refuel such equipment on a truck or trailer from a portable container, rather than from a gasoline dispenser nozzle.</li> <li>· If a gasoline dispenser nozzle must be used, keep the nozzle in contact with rim of the fuel tank or container opening at all times until fueling is complete.</li> </ul>
---

<p><b>POTENTIAL HAZARD</b></p> <ul style="list-style-type: none"> <li>· Gasoline vapor can collect inside enclosed trailers and may be ignited by electrical sparks or hot engine/exhaust components.</li> </ul>
<p><b>WHAT CAN HAPPEN</b></p> <ul style="list-style-type: none"> <li>· Explosion and fire may occur, resulting in property damage, personal injury, and/or death.</li> </ul>
<p><b>HOW TO AVOID THE HAZARD</b></p> <ul style="list-style-type: none"> <li>· Provide adequate ventilation of any enclosed trailer to prevent build up of gasoline vapors, especially at floor level.</li> <li>· Refuel only outdoors, never inside an enclosed trailer.</li> <li>· Be sure all fuel tanks and gasoline storage containers have proper caps installed to prevent spillage and minimize vapor escaping into the trailer.</li> <li>· Do not place any equipment that is leaking gasoline in an enclosed trailer.</li> </ul>

## 1.4 OPERATION

Although hazard control and accident prevention partially are dependent upon the design and



configuration of the equipment, these factors are also dependent upon the awareness, concern, prudence, and proper training of the personnel involved in the operation, transport, maintenance and the storage of the equipment. It is essential that all Operator Safety Mechanisms be connected and in operating condition prior to use for mowing.

<b>POTENTIAL HAZARD</b>
· Operating engine parts, especially the muffler, becomes extremely hot.
<b>WHAT CAN HAPPEN</b>
· Severs burns can occur on contact. · Debris, such as leaves, grass, bush, etc. can catch fire.
<b>HOW TO AVOID THE HAZARD</b>
· Allow engine parts, especially the muffler, to cool before touching. · Remove accumulated debris from muffler and engine area. · Install and maintain in working order a spark arrester before using equipment on forest-covered, grass-covered, or brush-covered unimproved land.

<b>POTENTIALHAZARD</b>
· Hands, feet, hair, clothing, or accessories can become entangled in rotating parts.
<b>WHAT CAN HAPPEN</b>
· Contact with rotating parts can cause traumatic amputation or severe lacerations.
<b>HOW TO AVOID THE HAZARD</b>
· Do not operate the machine without guards, shields, and safety devices in place and working properly. · Keep hands, feet, hair, jewelry, or clothing away from rotating parts.

1.4.1 Give complete, undivided attention to the job at hand.

1.4.2 Mow only in daylight or good artificial light, keeping away from holes and hidden hazards.

**NEVER** carry passengers. **DO** not operate the mower when children or others are in the area!

1.4.3 When feasible, avoid operating the equipment in wet grass.

1.4.4 Use mower caution when mowing and/or turning on slopes as loss of traction and/or tip-over could occur. The operator is responsible for safe operation on slopes.

<b>POTENTIAL HAZARD</b>
· Mowing on wet grass or steep slopes can cause sliding and loss of control.
<b>WHAT CAN HAPPEN</b>
· Wheels dropping over edges, ditches, steep banks, or water can cause rollovers, which may result in serious injury, death or drowning.
<b>HOW TO AVOID THE HAZARD</b>
· Do not mow on slopes when grass is wet. · Do not mow near drop-offs or near water. · Do not mow on slopes greater than 15 degrees. · Reduce speed and use extreme caution on slopes. · Avoid sudden turns or rapid speed changes.

- See inside the back cover to determine the approximate slope angle of the area to be mowed.
- Use a walk behind mower /or a hand trimmer near drop-offs, ditches, steep banks or water. This area can be dangerous, see Figure1.
- Progressively greater care is needed as the slope increases.
- Always avoid sudden starting or stopping on a slope. If tires lose traction, disengage the blades and proceed slowly off the slope.
- Avoid sudden starts when mowing uphill. Mower may tip backwards.
- Be aware that loss of traction may occur going downhill. Weight transfer to the front wheels may cause drive wheels to slip and cause loss of braking and steering.
- Watch for ditches. Holes, rocks, dips, and rises that change the operating angle, as rough terrain could overturn the machine.



- Use extreme care with grass catchers or attachments. These can change the stability of the machine and cause loss of control.

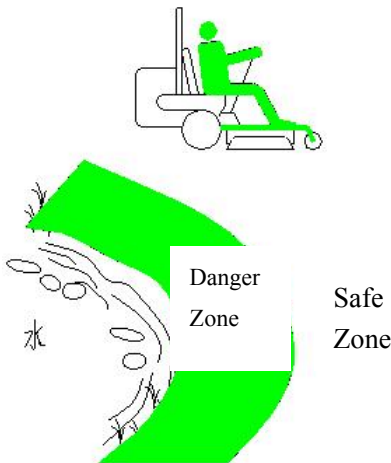



FIG 1

SAFE ZONE FOR MOWING

1.4.5 A Rollover Protection System (roll bar) is installed on the unit.

 <b>WARNING</b>
<p><b>POTENTIAL HAZARD</b></p> <ul style="list-style-type: none"> <li>· There is no rollover protection when the roll bar is down.</li> </ul>
<p><b>WHAT CAN HAPPEN</b></p> <ul style="list-style-type: none"> <li>· Wheels dropping over edges, ditches, steep banks, or water can cause rollovers, which may result in serious injury, death or drowning.</li> </ul>
<p><b>HOW TO AVOID THE HAZARD</b></p> <ul style="list-style-type: none"> <li>· Keep the roll bar in the raised and locked position and use seat belt.</li> <li>· lower the roll bar only when absolutely necessary.</li> <li>· Do not wear seat belt when the roll bar is down.</li> <li>· Drive slowly and carefully.</li> <li>· Raise the roll bar as soon as clearance permits.</li> </ul>

- Be certain that the seat belt can be released quickly if the machine is driven or rolls into ponds of water.
- Check carefully for overhead clearance. (i.e. branches, doorways, and electrical wires) before driving under any objects and do not contact them.

1.4.6 Use caution when backing up.

LOOK BEHIND YOU!!

1.4.7 Stop the blades when transporting the mower to and from the area to be mowed.

1.4.8. Never operate the mower with defective guards, shields, or covers. Always have safety shields, guards, switches, and other devices in place and in proper working condition.

1.4.9. DO NOT change the engine governor setting or overspend the engine. Operating an engine at excessive speed may increase the hazard of personal injury.

1.4.10 Disengage PTO before starting engine.

1.4.11 Start the engine carefully with feet well away from the blades.

1.4.12 Keep hands, feet, and clothing away from rotating parts while the mower is being operated.

1.4.13 Stop engine, wait for all mowing parts to stop , and remove key:

- Before checking, cleaning or working on the mower.
- After striking a foreign object (inspect mower for damage and make repairs before restarting and operating the mower).
- Before clearing blockages.
- When ever you leave the mower.

Stop the engine and wait for all moving parts to stop:

- Before refueling.
- Before dumping the grass catcher.

1.4.14. Before stopping the engine, place the throttle control **midway** between the “slow” and “fast” positions. Allow the engine to run a minimum of 15 seconds, then stop the engine.

1.4.15 The fuel system is provided with a shut-off valve, CLOSE VALVE:

- When the machine will not be used for a few days.
- During transport to and from the job.
- When parked inside a building.
- TO remove the fuel tank.

1.4.16 This mower was designed for one operator only. Keep all others away from mower during operation.



1.4.17 DO NOT mow with the discharge deflector raised, removed, or altered unless there is a grass collection system or mulch kit in place and working properly.

1.4.18 Be aware of the mower discharge and direct discharge away from others.

1.4.19. DO NOT operate the mower under the influence of alcohol and / or drugs.

1.4.20 Use extra care when approaching blind corners, shrubs, trees, or other objects that may obscure vision.

1.4.21 If jump starting is required:

a) Connect the positive (+) power cable to the positive terminal post on the starter solenoid switch

b) Connect the negative (-) power cable to any engine deck ground, preferably the engine block as far away from the battery as possible.

c) Disconnect battery cables in the reverse order after starting.

## 1.5 MAINTENANCE AND STORAGE

1.5.1 For engine maintenance, follow the engine manufacture's recommendations precisely as stated in the engine manual.

1.5.2 Disconnect the battery cable from the negative battery post when the unit will be allowed to sit for more than 30 days without use.

1.5.3 Allowing batteries to stand for an extended period of time without recharging them will result in reduced performance and service life. To preserve optimum battery performance and life, recharge batteries in storage when the open circuit voltage drops to 12.4 volts.

1.5.4 Keep engine, engine area, free from accumulation of grass, leaves, excessive grease, or oil and other debris, which can accumulate in this areas. These materials can become combustible and may result in a fire.

1.5.5. Store fuel in a container specifically designed for this purpose in a cool, dry place.

1.5.6. Keep the mower and fuel container in locked storage to prevent children from playing or tampering with them.

1.5.7. Gasoline powered equipment or fuel containers should not be stored in a basement or any enclosed area where open pilot lights or heat appliances are present.

1.5.8. Maximum mowing results and safety can only be achieved if the mower is properly maintained and operated correctly.

1.5.9. Check all bolts frequently to maintain proper tightness.

1.5.10. Keep all guard, shields and all safety devices in place and in safe working condition.

1.5.11. Frequently check for worn or deteriorating components that could create a hazard.

1.5.12. All replacement parts must be the same as or equivalent to the parts supplied on original equipment.



### POTENTIAL HAZARD

- Hydraulic fluid escaping under pressure can penetrate skin and cause injury.

### WHAT CAN HAPPEN

- Fluid accidentally injected into the skin must be surgically removed within a few hours by a doctor familiar with this form of injury or gangrene may result.

### HOW TO AVOID THE HAZARD

- Make sure all hydraulic fluid hoses and lines are in good condition and all hydraulic connections and fitting are tight before applying pressure to hydraulic system.
- Keep body and hands always from pinhole leaks or nozzles that eject high pressure hydraulic fluid.
- Use cardboard or paper, not your hands, to find hydraulic leaks.
- Safely relieve all pressure in the hydraulic system by placing the motion control levers in neutral and shutting off the engine before performing any work on the hydraulic system.

## 1.6 SAFETY SIGNS

1.6.1 Keep all safety signs legible. Remove all grease, dirt, and debris from safety signs and instructional labels.

1.6.2 Safety signs must be replaced if they are missing or illegible.

1.6.3 When new components are installed, be sure that current safety signs are affixed to the replaced components

1.6.4 New safety signs may be obtained from your authorized equipment dealer or distributor or from

**Worldlawn Power Equipment, Inc.**

1.6.5 Safety signs may be affixed by peeling off the backing to expose the adhesive surface. Apply only to clean, dry surface. Smooth to remove any air bubbles.

1.6.6 Familiarize yourself with the following safety signs and instruction labels. They are critical to the safe operation of your machine.



5. on the mower deck, RH



6. on the mower deck, LH

# WORLDLAWN

1. on the Front Frame

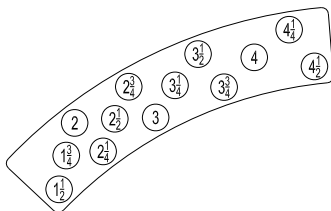

2. On the inner height adjustment plate



3. On the belt shields, LH and RH



4. under the belt shields, LH and RH

**WARNING**

To avoid serious injury or death:

- Read and understand the operator's manual before using the machine.
- Do NOT operate on slopes greater than 15°.
- Do NOT operate without shields, guards, and safety devices in place and working.
- Check the function of the operator presence control (OPC) safety system daily. Do NOT release the OPC system.
- Stop engine and remove key before adjusting, servicing, or clearing machine and leaving machine.
- Heating protection is recommended.

**WARNING**

Operation on wet grass or steep slopes can cause sliding and loss of control.

When self-cropping over edges can cause rollovers, which may result in serious injury, death or drowning.

- Do NOT operate on slopes greater than 15°.
- Do NOT operate on slopes greater than 15°.
- Reduce speed and use extreme caution on slopes.
- Avoid sudden turns or rapid speed changes.
- There is an rollover protection when the roll bar is down.
- Read and follow protection instruction and warnings.

**WARNING**

To avoid serious injury or death:

- Pick up objects that could be thrown by the blades.
- Do NOT use the grass area in the area.
- Do NOT carry passengers.
- Lock behind and to the side before changing directions.
- Before leaving operator's position:
- Disengage PTO.
- Move drive levers out to neutral lock position.
- Stop engine.
- Stop engine.

7. On the front frame

**WARNING**

**TO AVOID INJURY OR DEATH FROM ROLLOVER:**

Keep roll bar in the raised and locked position and use seat belt.

**THERE IS NO ROLL OVER PROTECTION WHEN THE ROLL BAR IS DOWN.**

Lower the roll bar only when absolutely necessary.

Do not wear seat belt when the roll bar is down.

Drive slowly and carefully.

Raise the roll bar as soon as clearance permits.

Read and follow slope operation instructions and warnings.

8. on the lower roll bar

**CAUTION**

DO NOT OPERATE WITHOUT GUARD IN PLACE

9. Top left on the back of the front frame

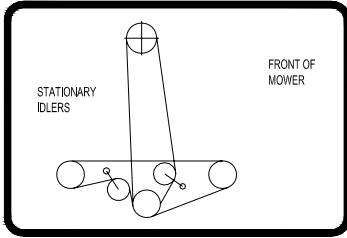

10. on the mower deck

**ANTI-SCALP ROLLER ADJUSTMENT**

FOR NORMAL OPERATING CONDITIONS, PLACE ROLLERS IN POSITIONS SHOWN FOR 3/4"(19) GROUND CLEARANCE.

CUTTING HEIGHT INCHES (mm)

- 2.0 (51)
- 2.5 (64)
- 3.0 (76)
- 3.5 (90)

FOR MAXIMUM FLOTATION, ROLLERS MAY BE POSITIONED LOWER, BUT MUST MAINTAIN A MINIMUM OF 1/4" GROUND CLEARANCE. NEVER POSITION THE ROLLERS TO SUPPORT THE MOWER DECK.

11. on the mower deck, LH

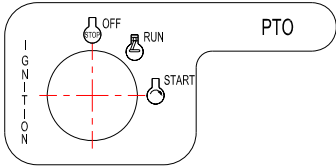

12. On the switch panel



13. On the switch panel

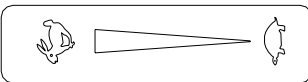

14. On the switch panel

HYDRAULIC OIL-USE ONLY  
MOBIL 1 SAE 15W-50  
SYNTHETIC ENGINE OIL  
FILL TO 4/5 OF HEIGHT OF HYDRAULIC RESERVOIR

**CAUTION**

HOT SURFACE

15. on the back of the fuel tank

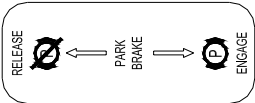

16. On the front of the console, LH

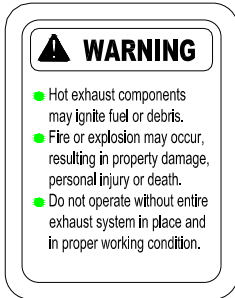

17. on the back of the fuel tank



18. Rear of the engine deck, top right hand

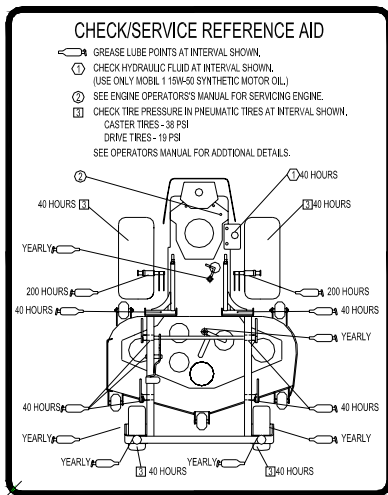

19. Front of the mower deck

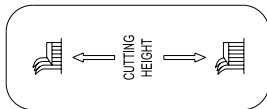

20. on the mower deck, RH

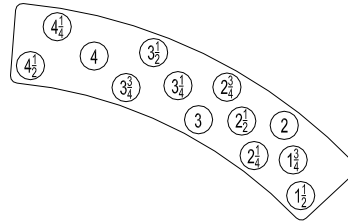

21. On the outer height adjustment plate

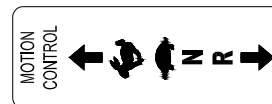

22. Top of the console, LH and RH

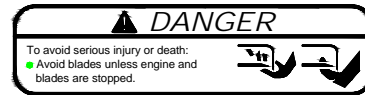

23. On of the console, LH and RH



24. Front of the 52" mower deck



25. Front of the 60" mower deck

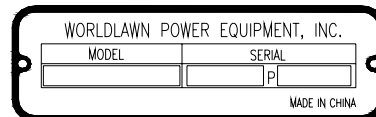

26. on the console, RH

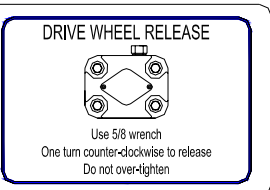
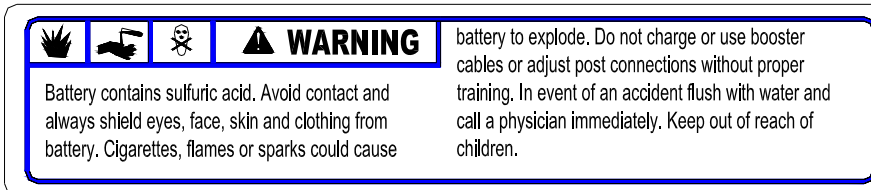

27. Center of the console



## 2.SPECIFICATIONS

### 2.1 MODEL NUMBER:

WYZ5222KW-H

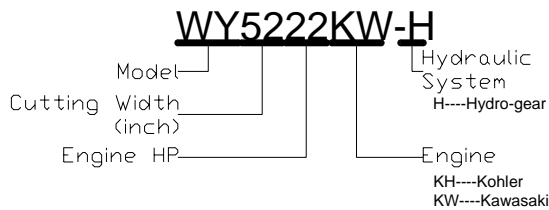

### 2.2 ENGINE:

- 2.2.1 Engine specifications: See Your Engine Owner's Manual
- 2.2.2 RPM: Full Speed:3600RPM(No Load) Idle:1500RPM

### 2.3 FUEL SYSTEM

- 2.3.1 Capacity: 10.5 gal(40L)
- 2.3.2 Type of Fuel: Regular unleaded gasoline, 87 octane or higher.
- 2.3.3. Fuel Shut-Off Valve: left tank, & right tank

### 2.4 ELECTRICAL SYSTEM

- 2.4.1 Charging System: Flywheel Alternator
- 2.4.2 Charging Capacity: 15 amps
- 2.4.3 Battery Type:12V/33AH
- 2.4.4 Polarity: Negative Ground
- 2.4.6 Fuses: Two 20 amp blade type
- 2.4.7 Safety Interlock System:
  - ◆ PTO must disengaged, brake engaged, and motion control levers out (neutral lock) to start engine. (It is necessary for the operator to be in the seat to start the engine.)
  - ◆ Operator must be in the seat when PTO is engaged, brake is disengaged, or motion control levers are moved in ,or engine will stop.
  - ◆ Engine will stop if the left, the right, or both levers are moved from neutral lock position while brake is engaged.

### 2.5 OPERATOR CONTROLS

- 2.5.1 Steering and Motion Control:



- . Separate levers, on each side of the console, control speed and direction of travel of the respective drive wheels.
- .Steering is controlled by varying the position of the levers relative to each other.
- .Moving motion control levers outward (in slots) lock the drive system in neutral.
- 2.5.2 PTO Switch: Engine electric clutch ( to drive belt)which engages mower blades.
- 2.5.3 Parking Brake Lever: Engages parking brakes.
- 2.5.4 Deck Height Adjustment Lever: Sets cutting height to desired position.
- Foot pedal that assists in raising the deck.

**2.6 SEAT**

- 2.6.1 Type: Standard seat: high back, foam padded(internal spring suspension) with arm rests.
- 2.6.2 Armrests: Standard seat: foam padded flip-up armrests with height adjustment.
- 2.6.3 Seat Safety Switch: Incorporated into the Safety Interlock System..
- Time delay seat switch eliminates rough ground cut-outs.

**2.7 HYDROSTATIC GROUND DRIVE SYSTEM**

**2.7.1 Hydraulic System Specification**

	<b>Hydro Gear</b>
Hydraulic pump	<b>Two 100cc</b> Displacement pumps.
Hydraulic Motors	<b>Two 250cc displacement</b> With 31.75mm tapered shafts
Hydrostatic Oil Type	Synthetic Mobil 1 SAE 15W-50
Hydrostatic Oil Capacity	3.2qt.(3.0L.)
Hydraulic Filter	Replaceable cartridge type. Flow: 7L/min, Precision: 25µm
Speeds	0-14.5(km/hr)forward 0-8.1(km/hr)reverse

**2.7.2.** Drive wheel release valves allow machine to be moved when the engine is not running.

**2.8 TIRES AND WHEELS**

Tires	Size(inch)	Qty (Units)	Tread	Ply	Inflation
Drive Tires	23*10.5-12	2	Turf	4	20psi(138kPa)



Caster Tires	13*5.00-6	2	Smooth	4	40psi(276kPa)
-----------------	-----------	---	--------	---	---------------

## 2.9 CUTTING DECK

### 2.9.1 Cutting Width:

WYZ52 deck	WYZ60 deck
52.8in(1342mm)	60.9in(1546mm)

### 2.9.2 Discharge: Side

### 2.9.3 Blade Size:(3ea.)

WYZ52 deck	WYZ60 deck
18in(457mm)	20.5in(520mm)

**2.9.4** Blade Spindles: Solid steel spindles with 25mm bearings.

**2.9.5** Deck Drive: Electric clutch mounted on vertical engine shaft. Blades are driven by one “B” Section belt (w/self-tensioning idler)direct from the engine.

**2.9.6** Deck: Full floating deck is attached to out-front support frame.

Maximum turf protection is provided by five anti-scalp rollers on deck.

Deck design allows for bagging, mulching, and side discharge.

**2.9.7** Cutting Height Adjustment: an extra-long cushioned lever (a foot operated deck lift assist lever to aid in raising the deck) used to adjust the cutting height from 1.5” (38mm) to 4.5”(114mm)in 0.25”(6.4mm)increments.

The cutting height adjustment handle has a transport position and all adjustments can be made while the operator remains seated.

**2.9.8 Mulching Kit:** Optional.

**2.9.9 Catching Kit:** Optional.

## 2.10 DIMENSIONS

### 2.10.1 Overall Width:

	Without deck (With Hydro Gear motors)	Discharge Chute Up	Discharge Chute Down
WYZ52 Deck	44.4in. (1128mm)	52.8in (1342mm)	62.7in. (1592mm)
WYZ60 Deck		60.9in. (1546mm)	70.7in. (1796mm)





**2.10.2 Overall Length:** Roll Bar-up: :62.7in.(1952mm)

Roll Bar-back: :84.3in.(2141mm)

**2.10.3 Overall Height:** Roll Bar-up: 70.7in.(1796mm)

Roll-Bar-down: 51.7in.(1313mm)

2.10.4 Tread Width : Drive Wheels(center of center of tires):39in.(992mm)

Front Casters (center of center of tires):37in.(940mm)

2.10.5 Wheel Base: 48.6in.(1235mm)

2.10.6 Overall Weight: WYZ52 is 1025Lbs (465 Kg)

WYZ60 is 1080Lbs (490Kg)

## 2.11 TORQUE REQUIREMENTS

<u>Bolt Location</u>	<u>Torque</u>
Cutter Housing Spindle Nut	190-197N-m
Blade Mounting Bolt	156-163N-m
Engine deck/front frame mount bolts:	41-47 N-.m
Nylon rollover bolts:	54-61 N-m
Hydraulic motor mount bolts	98-104N-m
Wheel hub slotted nut:	169 N-m
Rollover protection system (roll bar) mounting bolts:	41-47 N-m
Drive Wheel Mount Bolts:	128N-m

## 3. ASSEMBLY INSTRUCTIONS

### 3.1 UNCRATE MOWER

### 3.2 INSTALL ROLLER PROTECTION SYSTEM (ROLL BAR)

#### 3.2.1 Disassemble roll bar from the crate.

Loosen Rollover protection system (roll bar) mounting bolts in the crate. Take the roll bar with its bolts out.

#### 3.2.2 Raise the rear of the unit and support it with jack stands or equivalent support.

 CAUTION
<b>POTENTIAL HAZARD</b> · Raising the rear of the unit for assembly relying solely on mechanical or hydraulic jacks could be dangerous.
<b>WHAT CAN HAPPEN</b> ·The mechanical or hydraulic jacks may not be enough support or may malfunction allowing the

unit to fall, which could cause injury.

#### HOW TO AVOID THE HAZARD

· DO NOT rely solely on the mechanical or hydraulic jacks for support. Use adequate jack stands or equivalent support.

3.2.3 Remove the drive wheels from both sides of the unit.

3.2.4 Install the two lower roll bar tubes.

- a) Locate the left and right lower roll bar tubes.
- b) Align lower roll bar tubes along wheel motor channels as show in Figure 2.
- c) LOOSELY install lower roll bar hardware.

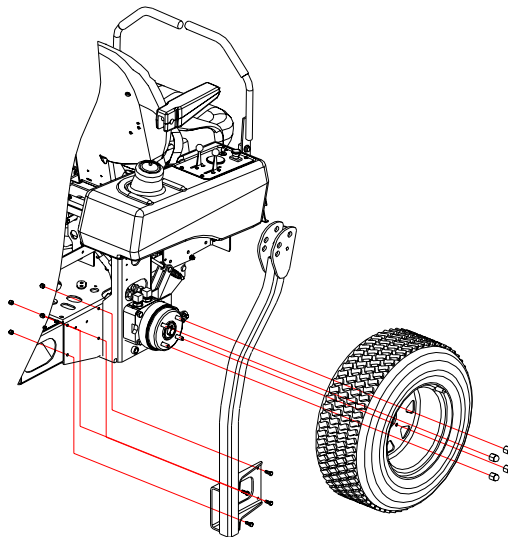

**FIG 2. Lower Roll Bar Installation**

3.2.5 Install the upper u-shaped section of the roll bar. (As show in Figure 3)

- a) Locate the latch pin assemblies(pin and hairpin connected with a lanyard)
- b) Locate the upper u-shaped section of the roll bar. Install the upper roller section using the bolts and lock nuts. Do not over tighten .Make sure upper roll bar can pivot freely.
- c) Torque all lower roll bar hardware attached to the machine frame to 41-47 N-m.
- d) Assembly the diver wheels on both sides, Torque all the nuts attached to the drive wheel to 128N.m.

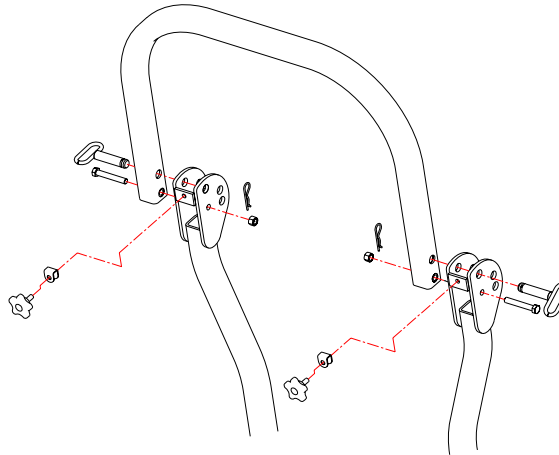

**FIG3. U – Shaped Bar Installation**

### 3.3 SERVICE BATTERY.



Battery posts, terminals, and related accessories contain lead compounds, chemicals known to cause cancer and reproductive harm.

**The machine is shipped with a filled lead acid battery without protection.**

3.3.1 Unhook seat latch and tilt seat to gain access to the battery.



#### **POTENTIAL HAZARD**

·Charging the battery may produce explosive gasses.

#### **WHAT CAN HAPPEN**

·Battery gasses can explode causing serious injury.

#### **HOW TO AVOID THE HAZARD**

·Keep sparks, flames, or cigarettes away from battery.

Ventilate when charging or using battery in an enclosed space.

3.3.2 Check the voltage of the battery with a digital voltmeter, Locate the voltage of the battery in the table below and charge the battery for the recommended time interval to bring the charge up to a full charge of 12.6Volts or greater.

**IMPORTANT:** Make sure the negative & positive battery cables are connected rightly, and the battery charger used for charging the battery has an output of 16 volts and 7 amps or less to avoid damaging the battery.



Voltage Reading	Percent Charge	Maximum Charger settings	Charging Interval
12.6 or greater	100%	16Volts/7 amps	No charging Required
12.4-12.6	75%-100%	16Volts/7 amps	30 Minutes
12.2-12.4	50%-75%	16Volts/7 amps	1 Hour
12.0-12.2	25%-50%	14.4Volts/4 amps	2 Hours
11.7-12.0	0-25%	14.4Volts/4 amps	3 Hours
11.7 or less	0%	14.4Volts/4 amps	6 Hours or more

! CAUTION
<p><b>POTENTIAL HAZARD</b></p> <ul style="list-style-type: none"> <li>·If the ignition is in the “ON” position, there is potential for sparks and engagement of components.</li> </ul>
<p><b>WHAT CAN HAPPEN</b></p> <ul style="list-style-type: none"> <li>·Sparks could cause an explosion or moving parts could accidently engage causing personal injury.</li> </ul>
<p><b>HOW TO AVOID THE HAZARD</b></p> <ul style="list-style-type: none"> <li>· Be sure ignition switch is in the “OFF” position before charging the battery.</li> </ul>

**3.3.3Connecting the negative battery cables:**

Note: If the positive cable is also disconnected, connect the positive (red) cable to the positive battery terminal first, then the negative (black) cable to the negative battery terminal. Slip insulator boot over the positive terminal.

Note: If time does not permit charging the battery, or if charging equipment is not available, connect the negative battery cables and run the vehicle continuously for 20 to 30 minutes to sufficiently charge the battery.

! CAUTION
<ul style="list-style-type: none"> <li>· Battery contains sulfuric acid, avoid contact and always shield eyes, face, skin and clothing from battery ,cigarettes, flames or sparks could cause battery to explode</li> <li>·Do not charge or use booster cables or adjust post connection without proper training;</li> <li>·If battery acid comes in contact with skin or eyes then flush with water and call a physician immediately.</li> <li>· Keep out of reach of children.</li> </ul>

**3.4 CHECK TIRE PRESSURE**

3.4.1 Check tire pressure in drive tires. Proper inflation for tires is20 psi (138kpa)

Check tire pressure in front tires. Proper inflation for tires is 40 psi (276kpa)

**3.5 INSTALL SEAT**

3.5.1 a) Remove seat assembly from the crate

- b) Remove four M8 nuts from the bottom of the seat. Retain for use later.
- c) Align the bolts on the bottom of the seat with the holes in the seat frame .Place seat on the top of the frame and secure with four nuts remove in step b.

### 3.6 INSTALL MOTION CONTROL LEVERS

- a) Loosen and remove the two bolts and washers which attach the motion control levers to the control arm shafts for shipping and the two bolts and washers which are screwed into the control arms shafts.
- b) Install the motion control lever onto the control arm shaft (see Figure 4)
  - Place the lever on the outside of the control arm shaft and secure with bolts and washers .Position the lever so the bolts are in the center of the slots on the lever mounting plate and tighten until snug. Repeat on opposite side of unit.

**NOTE: There are two lever height options available. Place the levers in the first and the third hole (from the top) to increase height of the levers, or in the first and the third hole(from the bottom) to decrease the height of the levers.**

- c) If the levers do not align with each other, when in the neutral position, loosen the hardware and make the appropriate adjustment by sliding the lever forward or backward until properly aligned and tighten hardware.
- d) If the ends of the levers hit against each other, while in the drive position, make adjustment by moving the lever outwards to the neutral lock position and carefully bending them outward. Move them back to the drive position and check for clearance, repeat if necessary.

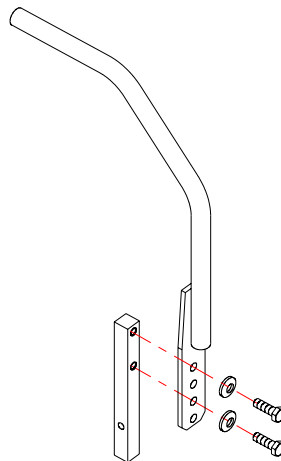

**FIG4. MOTION CONTROL LEVER ASSEMBLY**

### 3.7 POSITION DISCHARGE CHUTE

Loose two nuts M8 attaching discharge chute. Lower the discharge chute into position. Retighten nuts until chute is snug but can pivot freely.

### 3.8 SERVICE ENGINE

Engine is shipped with oil, check oil lever and if necessary fill to the appropriate lever with 10W-40



### 3.9. SERVICE HYDRAULIC OIL

The machine is shipped with hydraulic oil in the reservoir. Run the machine for approximately 15 minutes to allow any extra air to purge out of the hydraulic system. Check hydraulic reservoir and if necessary fill the reservoir to the appropriate level with Mobil 1 SAE 15W-50 synthetic motor oil. Replace hydraulic reservoir cap and tighten until snug. Do not over tighten.

## 4. OPERATION INSTRUCTIONS

### 4.1 CONTROLS

4.1.1 Familiarize yourself with all controls before operating the mower.

4.1.2 Motion Control Levers: Located on each side of the console.

The left lever controls the flow of hydraulic oil from the left hydrostatic pump to the left drive wheel motor.

The right lever controls the flow of hydraulic oil from the right hydrostatic pump to the right drive wheel motor.

**IMPORTANT: To begin movement (forward or backward), the operator must be in the seat, the brake lever must be disengaged before the motion control levers can be moved in or the engine will kill.**

When the levers are centered in the T-slot the drive system is in the neutral position. With levers moved out in the T-slot the drive system is in the **neutral lock** position. See Figure 5.

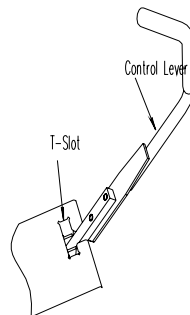

**FIG 5**  
**NEUTRAL LOCK POSITION**

By moving both levers an **equal** amount forward or back from the neutral position, the machine can be caused to move forward or backward in a straight line.

Movement of **the left lever forward** will cause the **left drive wheel** to rotate in a forward direction.

Movement of the **right lever forward** will cause the **right drive wheel** to rotate in a forward direction. To stop forward travel, pull the lever back to the neutral position.

To **turn left** while moving forward, move the **left lever** back toward neutral to slow the left drive wheel.

To **turn right** while moving forward, move the **right lever** back toward neutral to slow the right drive wheel.

To make a **zero turn** to the **left**, pull the left lever back beyond neutral while holding the right lever slightly ahead of neutral.

To make a **zero turn** to the **right**, pull the right lever back beyond neutral while holding the left lever

slightly ahead of neutral.

Pulling the **levers back** from the neutral position will cause the respective drive wheels to rotate in a reverse direction (when tension can be felt when moving into reverse from neutral).

To turn to the left while backing, move the left lever forward toward neutral. To turn to the right while backing, move the right lever forward toward neutral.

<p><b>POTENTIAL HAZARD</b></p> <ul style="list-style-type: none"> <li>· Machine can spin very rapidly by positioning one lever too much ahead of the other.</li> </ul>
<p><b>WHAT CAN HAPPEN</b></p> <ul style="list-style-type: none"> <li>· Operator may lose control of the machine, which may cause damage to the machine or injury.</li> </ul>
<p><b>HOW TO AVOID THE HAZARD</b></p> <ul style="list-style-type: none"> <li>· Use caution when making turns.</li> <li>· Slow the machine down before making sharp turns.</li> </ul>

4.1.3 Tracking Adjustment Knob: Located under the seat on the LH pump control link. See FIG 11

Rotating this knob allows fine turning adjustments so that the machine tracks straight with the drive levers in the full forward position.

Stop machine and wait for all moving parts to stop. Engage park brake. Unhook seat latch and tilt seat forward to gain access to the tracking knob .Rotate the knob counterclockwise (as viewed from the rear of the machine) to cause the machine to track more to the right and clockwise to cause the machine to track more to the left. Adjust in quarter-turn increments until the machine tracks straight. Check that the machine does not creep when in neutral with the park brakes disengaged.

**NOTE : Do not rotate the knob too far, as this may cause the creep in neutral; Refer to section 5.2.11 for control linkage adjustment.**

4.1.4 PTO Engagement Switch : \_ Locate on the right fuel tank.

Switch must be **pulled out** to the “**ROTATE**” position to engage the blades.

Switch is pushed in to the” **STOP**” position to stop the blades.

4.1.5 Choke Control: Located on the right fuel tank.

Choke is used to aid in starting a cold engine. Moving the choke lever **forward** will put the choke in the “**ON**” position and moving the choke lever **to the rear** will put the choke in the” **OFF**” position. DO NOT run a warm engine with choke in the “**ON**” position.

4.1.6 Throttle Control: Located on the right fuel tank.

Throttle is used to control engine speed. Moving throttle lever **forward** will increase engine speed and moving throttle lever **to the rear** will decrease engine speed..

4.1.7 Brake Lever: Located on left side of the console. The brake lever engages a parking brake on the drive wheels.

**Pull** the lever up and **rearward** to **engage** the brake.

**Push** the lever **forward** and **down** to disengage the brake.

4.1.8 Ignition Switch: Located on the right fuel tank.

Ignition Switch is used to start and stop the engine. The switch has three positions “**OFF**”,”**ON**” and



“START” .Insert the key into switch and rotate clockwise to the “ON” position.

Rotate clockwise to the next position to engage the starter (key must be held against spring pressure in this position)

**Brake must be engaged, motion control levers out (neutral lock position) and PTO switch “OFF” to start engine.**(It is not necessary for the operator to be in the seat to start the engine)

4.1.9 Hour Meter: Locate on the right fuel tank.

The hour meter is connected to a pressure switch installed in the engine block and it records the number of hours that the engine has run .If ignition switch is left on without engine running, hour meter will not run.

**NOTE: This switch is not a low oil sensor and will not alert the operator if the engine oil is low.**

4.1.10 Fuel Shut-Off Valve: Locate directly below center of console.

The fuel shut-off valve is used to shut off the fuel when the machine will not be used for a few days, during transport to and from the jobsite, and when parked inside a building.

- a) ROTATE The fuel shut-off valve counter-clockwise is to open the valve.
- b) ROTATE The fuel shut-off valve clockwise is to close the valve.
- c) The fuel shut-off valve on both side keep open, the fuel can flow through both tanks without restriction.

4.1.11. Drive Wheel Release Valves:

Release valves are used to release the hydrostatic drive system to allow the machine to be pushed without the engine running. Unhook seat latch and tilt seat up to gain access to pumps.

Hydra-Gear : Located on the right front corner of the hydrostatic pumps .

With a 5/8 wrench, turn both valves one turn counter-clockwise to release drive system.

Turn clockwise to reset system. **DO NOT over tighten. DO NOT tow machine.**

White: Located on the right front corner of the hydrostatic pumps .

With a 11/16wrench, turn counter-clockwise to loosen the nuts, then With a 5/16 wrench,. turn the valve counter-clockwise to release drive system.

Turn clockwise to reset system. **DO NOT over tighten. DO NOT tow machine.**

4.2 PRE-START

4.2.1 Fill fuel tanks .For best results use only clean, fresh regular grade unleaded gasoline with an octane rating of 87 or higher. Regular grade leaded gasoline may also be used; however, combustion chamber and cylinder head will require more frequent service; see Engine Owner’s Manual, **DO NOT** add engine oil to gasoline.

**Do Not** overfill fuel tank.

4.2.2 Make sure you understand the controls, their locations, their functions, and their safety requirements.

4.2.3 Refer to Maintenance. Section 5, and perform all necessary inspection and maintenance steps.

4.2.4 Check the tire inflation:

wheels	Inflation
Drive wheels	20psi(138kPa)
Caster wheels	40psi(276kPa)





### 4.3 MOWING

4.3.1 Operate units with all roll bars in the raised and locked position and use seat belt; there is no rollover protection when the roll bar is down. If it is necessary to lower roll bar do not wear seat belt. Raise the roll bar as soon as clearance permits.

4.3.2 Open fuel shut-off Valve (left or right tank).

#### 4.3.3 Starting Engine

**Brake must be engaged, the PTO switch disengaged, and the motion control levers out (neutral lock position).** (The operator does not need to be in the seat to start the engine)

On a cold **engine**, place the **throttle midway** between the “SLOW” and “FAST” positions and push **choke** lever forward to the “ON” position. Turn ignition switch to the “start” position. Release the switch as soon as engine starts.

**IMPORTANT: DO NOT crank the engine continuously for more than 10 seconds at a time. If the engine does not start, allow a 60 seconds cool-down period between starting attempts. Failure to follow these guidelines can burn out the starter motor.**

After starting a cold engine, gradually return choke to the “OFF” position as the engine warm up.

On a **warm** engine, place the **throttle midway** between the “SLOW” and “FAST” positions and leave the **choke** in the “OFF” position.

#### 4.3.4 Engage PTO

 <b>DANGER</b>
<b>POTENTIAL HAZARD</b> · The rotating blades under the mower deck are dangerous.
<b>WHAT CAN HAPPEN</b> · Blade contact can cause serious injury or kill you.
<b>HOW TO AVOID THE HAZARD</b> · DO NOT put hands or feet under the mower or mower deck when the blades are engaged.

 <b>DANGER</b>
<b>POTENTIAL HAZARD</b> · An uncovered discharge opening will allow objects to be thrown in an operator’s or bystanders’ direction. Also contact with the blade could occur.
<b>WHAT CAN HAPPEN.</b> · Thrown objects or blade contact can cause serious injury or death.
<b>HOW TO AVOID THE HAZARD</b> · Never operate the mower with the discharge deflector raised, removed, or altered unless there is a grass collection system or mulch kit in place and working properly.



The PTO clutch push-pull switch engages the cutting blades. Be sure that all persons are clear of mower deck and discharge area **before engaging PTO**.

**IMPORTANT: Operator must be in seat before the PTO can be engaged.**

Set throttle to “midway” position. Pull outward on the switch to the “ROTATE” position. Accelerate to full throttle to begin mowing.

4.3.5 Stopping PTO: Set the throttle to the “midway” position, push in on the switch to the “STOP” position and stopping the PTO.

4.3.6 Stopping engine: Bring unit to a full stop .Disengage the PTO, move motion control levers to the neutral lock position and engage parking brake.

Rotate ignition switch to “OFF” position. Remove the key to prevent children or other unauthorized persons from starting the engine.

Close fuel shut-off valve when the machine will not be used for a few days, when transporting, and when the unit is parked inside a building.

4.4 TRANSPORTING

4.4.1 Transporting a unit: Use a heavy-duty trailer or truck to transport the machine.

Lock brake and block wheels. Securely fasten the machine to the trailer or track with straps, chains, cable, or ropes .Be sure that the trailer or track has all necessary lighting and marking as required by law.

<b>POTENTIAL HAZARD</b>
· This unit does not have proper turn signals, lights, reflective markings, or a slow moving vehicle emblem. These items are required to drive on a public street or roadway.
<b>WHAT CAN HAPPEN</b>
· Driving on a street or roadway without such equipment is dangerous and can lead to accidents causing personal injury. · Driving on a street or roadway without such equipment may also be a violation of state laws and the operator may be subject to traffic tickets and /or fines.
<b>HOW TO AVOID THE HAZARD</b>
· Do not drive a unit on a public street or roadway.

<b>POTENTIAL HAZARD</b>
· Loading a unit on a trailer or truck increases the possibility of backward tip-over.
<b>WHAT CAN HAPPEN</b>
·Backward tip-over of the unit could cause serious injury or death.



## HOW TO AVOID THE HAZARD

- Use extreme caution when operating a unit on a ramp.
- Use only a single, full width ramp: DO NOT use individual ramps for each side of the unit.
- If individual ramps must be used, use enough ramps to create an unbroken ramp surface wider than the unit.
- DO NOT exceed a 15° angle between ramp and ground or between ramp and trailer or truck.
- Avoid sudden acceleration while driving unit up a ramp to avoid tipping backward.
- Avoid sudden deceleration while backing unit down a ramp to avoid tipping backward.

4.4.2 Loading a Unit: Use extreme caution when loading units on trailer or trucks.

One full width ramp that is wide enough to extend beyond the rear tire is recommended instead of individual ramps for each side of the unit. The lower rear section of the tractor frame extends back between the rear wheels and serves as a stop for tipping backward. Having a full width ramp provides a surface for the frame members to contact if the unit starts to tip backward. If it is not possible to use one full width ramp, use enough individual ramps to simulate a full width continuous ramp.

Ramp should be long enough so that the angles between the ramp and the ground and the ramp and the trailer or truck do not exceed 15°.

DO NOT attempt to turn the unit while on the ramp, you may lose control and drive off the side.

Avoid sudden acceleration when driving up a ramp and sudden deceleration when backing down a ramp. Both maneuvers can cause the unit to tip backward.

## 5. MAINTENANCE & ADJUSTMENTS

### 5.1 PERIODIC MAINTENANCE

#### 5.1.1 Check the engine oil level:

##### Service Interval: Daily

- a) Stop engine, wait for all moving parts to stop and make sure unit is on a level surface.
- b) Check with engine cold.
- c) Clean area around dipstick. Remove dipstick and wipe oil off. Reinsert the dipstick. Do not screw into place. Remove the dipstick and read the oil level.
- d) If the oil level is low, add oil to bring the oil level up to the “FULL” mark on the dipstick. Use oil as specified in the Engine Owner’s Manual.

**Do not overfill.**

**IMPORTANT: DO NOT operate the engine with the oil level below the “LOW”( or “ADD” ) mark on the dipstick, or over the “FULL” mark.**

#### 5.1.2 Clean engine cooling system:

Service Interval: Daily or more often in dry conditions



<b>POTENTIAL HAZARD</b> ·Excessive debris can cause the engine and hydraulic system to overheat.
<b>WHAT CAN HAPPEN</b> ·Excessive debris around the engine cooling air intake and inside of the pump compartment can create a fire hazard.
<b>HOW TO AVOID THE HAZARD</b> · Clean all debris from around the engine and hydraulic pumps daily.

- a) Stop engine, wait for all moving parts to stop, and remove the key.
- b) Clean all debris from rotating engine air intake screen and from around engine shrouding

### 5.1.3 Check battery charge:

Service Interval: Monthly

Allowing batteries to stand for an extended period without recharging them will result in reduced performance and service life. To preserve optimum battery performance and life, recharge them in storage when the open circuit voltage drops to 12 Volts.

Note: To prevent damage due to freezing, battery should be fully charged before putting away for winter storage.

- a) Check the voltage of the battery with a digital voltmeter. Locate the voltage reading of the battery in the table(See chart 3.3.2 ) and charge the batter for the recommended time interval to bring the charge up to a full charge of 12.6 Volts or greater.

**IMPORTANT:** Make sure the negative & positive battery cables are connected rightly, and the battery charger used for charging the battery has an output of 16 volts and 7 amps or less to avoid damaging the battery.(see chart 3.3.2 for recommended charger settings.)

### 5.1.4 Clean grass build-up under deck.

Service Interval: Daily

- a) Stop engine, wait for all moving parts to stop, and remove key.
- b) Raise deck to the transport position. Lift the front of unit and support unit using jack stands or equivalent support.



**POTENTIAL HAZARD**

· Raising the mower deck for service or maintenance relying solely on mechanical or hydraulic jacks could be dangerous.

**WHAT CAN HAPPEN**

· The mechanical or hydraulic jacks may not be enough support or may malfunction allowing the unit to fall, which could cause injury.

**HOW TO AVOID THE HAZARD**

· DO NOT rely solely on mechanical or hydraulic jacks for support. Use adequate jack stands or equivalent support.

c) Clean out any grass build-up from underside of deck and in discharge chute.

**5.1.5 Check mower blades**

**Service Interval: Daily**

- a) Stop engine, wait for all moving parts to stop, and remove the key.
- b) Lift deck and secure in raised position as stated in Section 5.1.4.
- c) Inspect blades and sharpen or replace as required.
- d) Re-install the blades(if they were removed)by placing a block of wood between the front or rear baffles and the blade then torque the blade bolts to 115-120ft.lbs(156-163 N-M).Be sure the spring disk washer cone is installed toward the bolt head.(See Figure 6).

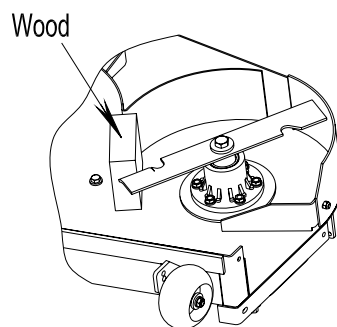

**FIG6  
BLADE INSTALLATION**



**POTENTIAL HAZARD**

· Operating a mower deck with loose or weakened blade bolts can be dangerous.

**WHAT CAN HAPPEN**

· A loose or weakened blade could allow a blade rotating at a high speed to come out from under the deck, causing serious injury or property damage.

**HOW TO AVOID THE HAZARD**

- DO NOT lubricate the threads of the bolt or spindle before assembly.
- Torque the blade bolt to 115-120ft.lbs (156-163 N-M).

**5.1.6 Check safety interlock system.**

Service Interval: Daily

- a) Check starting circuit.

Starter **should** crank with parking brake **Engaged**, PTO **Disengaged** and motion control levers moved out in the **Neutral Lock** position .The operator does not need to be in the seat to start the engine.

Try to start with **Operator In Seat**, parking brake **Engaged**, PTO **Engaged** and motion control levers in the **Neutral Lock position-starter Must Not Crank**.

Try to start with **Operator In Seat** , parking brake **Engaged**, PTO **Disengaged**, and the **Left Motion Control Lever In** , **start must not crank** , repeat again with **the right lever in** , **then with both levers in starter must not crank**.

- c) Check kill circuit.

Run engine at one-third throttle, **Disengaged** parking brake and **Raise Off** of seat (but not get off machine) Engine Must Stop after approx. 1.5 second has elapsed (seat has time delay kill switch to prevent cut-outs on rough terrain).

Run engine at one-third throttle, **Engaged** parking brake, **Engage** PTO and Raise Off seat (but do not get off machine) Engine Must Stop after 1.5 second has elapsed.

Run engine at one-third throttle, with brake engaged, move levers in ----Engine must stop.

Again, run engine at one-third throttle, **brake Engaged**, and move **Left Motion Control Lever In-engine Must Stop**.

Repeat again moving the **Right Lever In**, then moving **Both Levers In-Engine Must Stop** whether operator is **On Seat or Not**.

**NOTE: If machine does not pass any of these tests, do not operate. Contact your authorized WORLDLAWN POWER EQUIPMENT SERVICE DEALER.**

IMPORTANT: It is essential that operator safety mechanisms be connected and in proper operating condition prior to use for mowing.

**5.1.7 Check rollover protections systems (roll bar)**

Service Interval: Daily

- a) Make sure latch pin and hair pin are fully installed and lanyard is in good condition.



#### 5.1.8 Check for loose hardware.

Service Interval: Daily

- a) Stop engine, wait for all moving parts to stop, and remove key.
- b) Visually inspect machine for any loose hardware or any other possible problem. Tighten hardware or correct the problem before operating.

#### 5.1.9 Service air cleaner.

**Service Interval: 50 hrs.**

**More often under severe conditions.**

**See Engine manual for additional information.**

- a) Stop engine, wait for all moving parts to stop, and remove the key.
- b) Loosen retaining clips and remove air cleaner compartment cover.
- c) Remove paper element. Check the condition of the paper element.  
Replace if dirty, bent or damaged.
- d) **DO NOT** wash or use pressurized air to clean paper element or inner element.

#### 5.1.10 Change engine oil.

**Service Interval: 100 hrs.**

NOTE: Change oil and filter after first five (5)hrs. of operation.

- a) Stop engine, wait for all moving parts to stop, and remove key.
- b) Drain oil while engine is warm from operation.
- c) Oil drain valve is located on left hand side of Kohler engine /on the right hand side of Kawasaki engine..  
Place pan under machine to catch oil and open valve with 10mm wrench. Allow oil to drain then close valve.
- d) Replace the oil filter **Every Other** oil change. Clean around oil filter and unscrew filter to remove. Before reinstalling new filter, apply a thin coating of oil on the surface of the rubber seal. Turn filter clockwise until rubber seal contacts the filter adapter then tighten filter an additional 2/3 to 3/4 turn.
- e) Clean around oil fill cap and remove cap .Fill to specified capacity and replace cap. Use oil recommended in engine owner's manual. **DO NOT** overfill.
- f) Start the engine and check for leaks. Stop engine and recheck oil level.

#### 5.1.11 Check hydraulic oil level:

**Service Interval: 40hrs.**

- a) Stop engine and wait for all moving parts to stop.
- b) Clean area around hydraulic reservoir cap and remove cap.
- c) Oil level should be to the 2/3 top inside the tank. If not add oil. Use only Mobil 1 SAE15w-50 synthetic motor oil. Replace hydraulic reservoir cap and tighten until snug .Do not **over tighten**.

#### 5.1.12 Check tire pressures:

**Service Interval: 40hrs.**

- a) Stop engine, wait for all moving parts to stop, and remove key.



- b) Check tire pressure in drive tires.  
Inflate drive tires to 20psi (138kPa).
- c) Check tire pressure in Caster tires.  
Inflate caster tires to 40psi (276kPa).

5.1.13 Check condition of belts:

**Service Interval: 40hrs.**

- Stop engine, wait for all moving parts to stop, and remove key.
- Check under engine deck to check pump drive belt.
- Remove left and right belt shields on deck and lift out floor pan to inspect deck drive belt.
- See Sections 5.2.3 and 5.2.4. for belt adjustment.

5.1.14 Lubricate grease fitting:

Service Interval: Refer to chart.

- Stop engine, wait for all moving parts to stop, and remove key.

LUBRICATION CHART

FITTING LOCATIONS	INITIAL PUMPS	NO. of PLACES	SERVICE INTERVAL
Front Caster wheel hubs	1	2	yearly
Front Caster Pivots	1	2	Yearly
Height adjustment Shaft Bearing	1	5	40hours
Deck Drive Belt Idler Arm	1	1	40hours
Brake Brackets	1	2	200hours
Pump Drive Belt Idler Arm	1	1	40hours
Deck Rear Struts	1	2	40hours

**5.1.15 Lubricate seat switch actuator:**

Service Interval: 160hrs.

- a) Stop engine, wait for all moving parts to stop, and remove key.
- b) Unhook seat latch and tilt seat up.
- c) Lubricate switch actuator rod with spray type lubricant or light oil.

**5.1.16. Lubricate brake handle pivot:**

Service Interval: 160hrs.

- a) Stop the engine, wait for all moving parts to stop, and remove key.
- b) Lubricate bronze bushing on brake handle pivot with a spray type lubricant or light oil.

**5.1.17 Lubricate brake rod bushings:**

Service Interval: 160hrs.

- a) Stop engine, wait for all moving parts to stop, and remove key.
- b) Unhook seat latch and tilt seat up.
- c) Lubricate bronze bushing on each end of brake rod shafts with a spray type lubricant or a light oil.





---

One shaft is located under the console .The other is below and behind the seat.

5.1.18 Lubricate motion control bronze bushing:

Service Interval: 160hrs.

- a) Stop engine, wait for all moving parts to stop, and remove key.
- b) Unhook seat latch and tilt seat up.
- c) Lubricate bronze bushings on flange bearing securing the motion control arm shafts with a light oil or a spray type lubricant.

5.1.19. Remove engine shrouds and clean cooling fins:

**Service Interval: 80hrs.**

- a) Stop engine, wait for all moving parts to stop, and remove key.
- b) Remove cooling shroud clean-out covers from engine and clean cooling fins .Also clean dust, dirt and oil from external surface of engine which can cause improper cooling.
- c) Make sure cooling shroud clean-out covers or cooling shrouds are reinstalled. Operating the engine without cooling shroud clean-out covers or cooling shrouds will cause engine damage due to overheating.

5.1.20. Check spark plugs:

Service Interval: 160hrs.

Remove spark plugs, check condition and reset gaps, or replace with new plugs.

5.1.21.Change fuel filter:

Service Interval: As Required

- a) A fuel filter is installed between the fuel tanks and the engine.

5.1.22. Change hydraulic system filter:

Service nterval: After First 250hrs.Then yearly thereafter

NOTE: Filter Oil: 25um.

- a) Stop engine, wait for all moving parts to stop, and remove key.
- b) Locate filter on the left side of the engine.
- c) Carefully clean area around filter. It is important that no dirt or contamination enter hydraulic system.
- d) Unscrew filter to remove and allow oil to drain from reservoir.

**IMPORTANT: Before reinstalling new filter, fill it with Mobil 1 SAE 15W-50 and apply a thin coat of oil on the surface of the rubber seal.**

Turn the filters clockwise until rubber seal contacts the filter adapter then tighten the filter an additional 2/3 to 3/4 turn.

- e) Fill reservoir as stated in Section 5.1.11.
- f) Raise the rear of machine up and support with jack stands (or equivalent support) just high enough to allow drive wheels to turn freely.
- g) Start engine and move throttle control ahead to full throttle position. Move the speed control levers to the full speed and run for several minutes .Shut down machine and recheck oil level.

Do not change hydraulic system oil (except for what can be drained when changing filter), unless it is felt the oil has been contaminated or been extremely hot.

**5.1.23. Wheel hub-slotted nut torque specification.**

When tightening the slotted nut on the wheel motor tapered shaft:

- a) Torque the slotted nut to 169N.m.
- b) Check distance from bottom of slot in nut to inside edge of hole. Two threads or less should be showing.
- c) If more than two threads are showing remove nut and install washer between hub and nut.
- d) Torque the slotted nut to 169N.m.
- e) Then tighten the nut until the next set of slots line up with the cross hole in the shaft.
- f) Replace cotter pin.

#### 5.1.25 Fuel Tank- mounting hardware specification.

Install the bolts on the nuts onto the fuel tank studs

### 5.2 ADJUSTMENTS

**IMPORTANT:** Disengage PTO, shut off engine, wait for all moving parts to stop, and remove key before servicing, cleaning or making adjustments to the unit.

#### 5.2.1 Cutting Height Adjustment.

- a) Stop engine, wait for all moving parts to stop, and remove key.
- b) Disengage PTO.
- c) Raise the deck lever to the transport position (the highest lock position)

**NOTE: When changing cutting height positions, always come to a complete stop and disengage the PTO.**

- d) Insert height adjustment pin into hole corresponding to desired cutting height and install hairpin cotter. See decal on deck lift plate.
- e) Tread the high adjustment pedal, push the button which is on the top of the high adjustment lever. Loosen to the selected position.
- f) To transport, move lever back up to transport position. (The highest lock position)
- g) Adjust anti-scalp rollers for Normal Operating Conditions. Stop engine, wait for all moving parts to stop, and remove key. Place rollers in one of the Position shown in Figure 7. Rollers will maintain 3/4 in. (19mm) clearance to the ground to minimize gouging and roller wear or damage.

For Maximum Deck Flotation, place rollers one hole position lower. Rollers should maintain 1/4 in. (6.4mm) minimum clearance to ground. Do Not adjust rollers to support the deck. Be sure bolt is tightened properly or loss of anti-scalp roller may result.

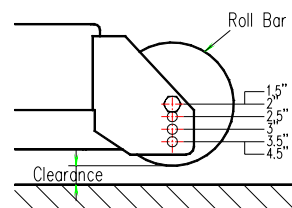
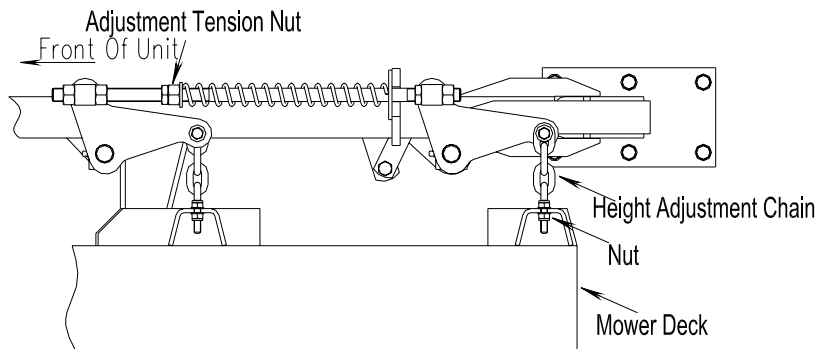

FIG 7

#### 5.2.2 Deck Leveling:

- a) Position mower on a flat surface.
- b) Stop engine, wait for all moving parts to stop, and remove key.
- c) Check tire pressure in drive tires. Proper inflation pressure for tires is 20psi (138kPa). Adjust if necessary.
- d) Check tire pressure in Caster tires. Proper inflation pressure for tires is 40psi (276kPa)

- e) Set anti-scalp rollers to top holes or remove them completely for this adjustment.
- f) Raise the deck to the highest lock position and take as much force as possible off of the two large deck lift springs by loosening the nuts at the front of each spring. See Figure 8.



**FIG 8**

- g) Lower the deck to the 1-1/2" (3.8cm) height position. Place two 1-5/16 (3.3cm) thick blocks under the rear edge of cutting deck skirt; one on each side of the cutting deck. Place a 2.7cm block under the center front edge, but not under the anti-scalp roller brackets.
- h) Recheck that blocks fit just snugly under the deck skirt and that the tension on all the chains are approximately equal. Make sure all chain attachment bolts are tight.
- i) Raise deck lift lever to the highest lock position. Adjust spring compression turning the nut at the front of each spring . **NORMALLY** the length of the spring should be adjusted to 280mm.
- j) Reposition anti-scalp rollers and tighten securely.

**NOTE: When above adjustments have been made, the front of the deck will be slightly lower than the rear of the deck, approximately 6mm.**

#### 5.2.3 Pump Drive Belt Tension.

Self-tensioning- No adjustment necessary.

#### 5.2.4 Deck Belt Tension.

Self-tensioning- No adjustment necessary.

#### 5.2.5 Adjust Seat Switch.

If necessary, adjust the seat actuator rod length to where the machine will shut off when the operator raises off the seat (with brake disengaged or PTO engaged) but will continue to run with operator in seat. Normal adjustment is when length of spring is 4.5cm.

NOTE: To prevent rough ground cut-outs the unit is equipped with a time delayed seat switch. When the operator raises off the seat with either the brake disengaged or the PTO engaged, the engine should stop after 4-5 second has elapsed.

#### 5.2.6 Brake Link Adjustment.

Check to make sure brake is adjusted properly.

- a) Disengage brake lever (lever down).

- b) Measure the length of the spring. Measurement should be 2.75" (70mm) between washers (see Figure 9).
- d) If adjustment is necessary, tighten the lock nut directly below the yoke and loosen the two nuts jammed together below the spring. Turn the nut directly below the washer until the correct measurement is obtained. Tighten the two jam nuts below the spring together and repeat on opposite side of unit.

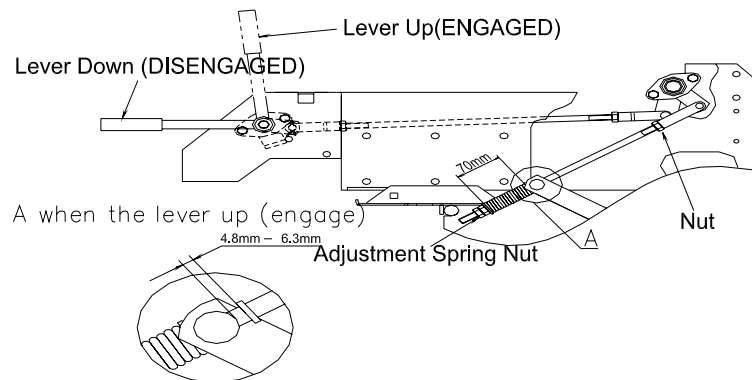

**FIG9. Brake Adjustment**

#### 5.2.7 Brake Adjustment.

- Check for brake link 2.75" (7.0cm) measurement as described
- Engine brake lever (lever up).
- Measure the distance between the trunnion roller and the rod collar as shown in Figure9. Measurement should be 5mm with shim gauge.
- If adjustment is necessary, loosen the nut directly below the yoke. Turn the bottom nut (below washer) until the correct measurement is obtained turn nut clockwise to lengthen the gap (screws rod out of yoke). Tighten nut against yoke and check opposite side of unit, repeat if necessary.

#### 5.2.8 Adjust Throttle Lever Tension.

- Stop engine wait for all moving parts to stop, and remove key.
- Tension in throttle lever can be adjusted by adjusting the tightness of the lever pivot bolt, which is located under the console.

#### 5.2.9 Electric Clutch Adjustment:

**No adjustment necessary.**

#### 5.2.10 Reverse Adjustment:

No adjustment necessary.

#### 5.2.11 Motion control linkage adjustment.



#### **POTENTIAL HAZARD**

◆ Engine must be running and drive wheels must be turning so motion control adjustment can be performed.



**WHAT CAN HAPPEN**

- ◆ Contact with moving parts or hot surface may cause personal injury.

**HOW TO AVOID THE HAZARD**

- ◆ Keep fingers, hands, and clothing clear of rotating components and surfaces.

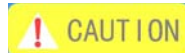

**POTENTIAL HAZARD**

- ◆ Raise the mower deck for service or maintenance relying solely on mechanical or hydraulic jacks could be dangerous.

**WHAT CAN HAPPEN**

- ◆ The mechanical or hydraulic jacks may not be enough support or may malfunction allowing the unit to fall, which could cause injury.

**HOW TO AVOID THE HAZARD**

- ◆ Do not rely solely on mechanical or hydraulic jacks for support. Use adequate jack stands or equivalent support.

- a) This adjustment must be made with the drive wheels turning. First raise the frame and block up so that drive wheels can rotate freely.
- b) Remove the electrical connection from the seat safety switch, located directly to the left of the seat switch assembly beside the hydraulic oil reservoir. **Temporarily** install a jumper wire across the terminal in connector of the wiring harness.
- c) Run the unit at least 5 minutes with the drive levers at full forward speed to bring hydraulic system oil up to operating temperature.
- d) Unhook seat latch and tilt seat forward.
- e) Start engine. **Brake must be engaged and motion control levers out to start engine .operator does not have to be in the seat because of the jumper wire being used.** Run engine at full throttle and release brake.
- f) The reverse indicator spring must be correct before the following adjustments can be made.

**NOTE: The motion control lever needs to be in neutral while making any necessary adjustments.**

The left rod assembly controls the left wheel and the right rod assembly controls the right wheel.

- g) Bring the RH motion control lever into the neutral position. Adjust RH pump control rod length by rotating the double nuts on the rod on the appropriate direction until the wheels slightly creep in reverse. Move the motion control lever to the reverse position and while applying slight pressure to the lever. The wheel must stop turning or slightly creep in reverse. When adjustment is complete, tighten lock nuts onto ball joints.

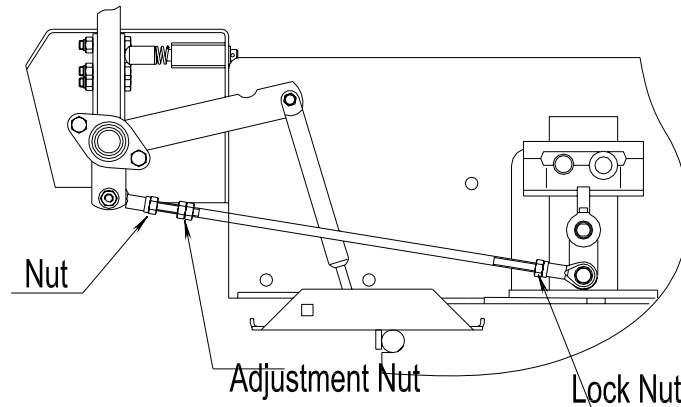

**FIG 10.RH Pump Adjustment**

- h) Bring the LH motion control lever into the neutral position. Adjust the LH pump control rod length by rotating the tracking adjustment knob in the appropriate direction until the wheels slightly creep in reverse. Move the motion control lever to the reverse position and while applying slight pressure to the lever allow the reverse indicator spring to bring the levers back to neutral. The wheel must stop turning or slightly creep in reverse.

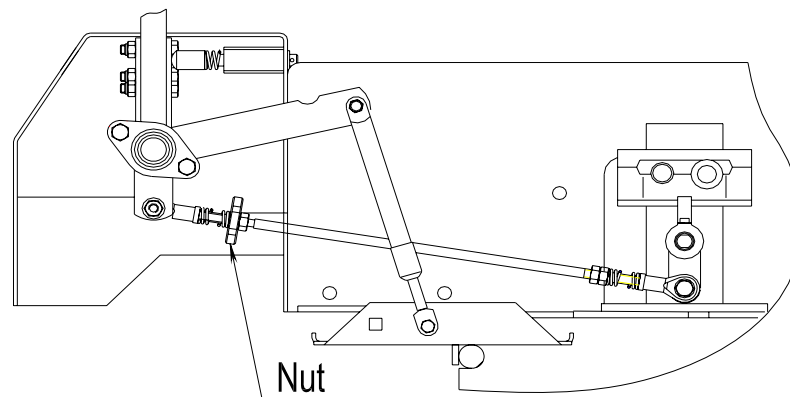

**FIG11. LH Pump Adjustment**

Remove jumper wire from wire harness connector and plug connector into seat switch.

#### 5.2.12 Caster pivot bearing pre-load adjustment.

Remove dust cap from caster and tighten nylon nut until washers are flat and back off 1/4 of a turn to properly set the preload on the bearings .If disassembled make sure the spring washers are reinstalled as shown in Figure 12.

## 6 TROUBLE SHOOTING

### 6.1 MOWER PULLS LEFT OR RIGHT (W/LEVERS FULLY FORWARD).

- a) Refer to tracking Adjustment Section 4.1. 3.
- c) Check air pressure in tires: 20psi/drive, 40psi/pneumatic casters.

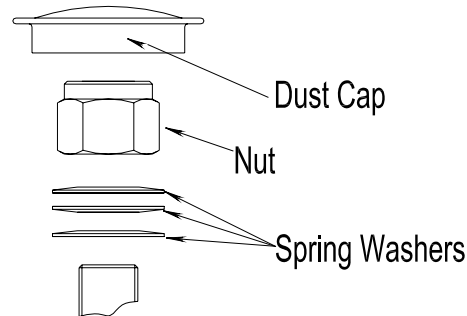

**FIG12. Caster Adjustment**

### 6.2 MOWER CUTS UNEVENLY.

- a) Check air pressure in tires; 20psi/drive, 40psi/pneumatic casters.
- b) Check deck support chains.
- c) Check deck leveling (See Adjustments Section 5.2.2)

Note: The front of the mower deck will be approximately 6 mm lower than the back of the mower deck; this is the “rake” of the deck.

- d) Check blades tip to tip for straightness

### 6.3 ENGINE WILL NOT START

- a) Make sure battery is at a full charge.
- b) Be sure the throttle control is midway between the “SLOW” and “FAST” positions, and the choke is in the “ON” position for a cold engine or the “OFF” position for a warm engine.
- c) Make sure there is fuel in the fuel tank and that the fuel valve is open.
- d) Be sure the seat switch is properly adjusted. See Section 5.2.5.
- e) Make sure the parking brake is set and motion control levers are moved out (neutral lock position).
- f) Check that the PTO is disengaged.
- g) Check that the spark plug wires are properly connected.
- h) Check for loose or faulty wiring connections.
- i) Check for corrosion at all wiring connections. Even minor corrosion may cause a faulty connection. Clean connector terminals thoroughly with electrical contact cleaner, apply dielectric grease and reconnect.

**NOTE:** After carefully checking the above steps, attempt to start the engine. If it does not start, contact your authorized machine service dealer.

**IMPORTANT:** It is essential that all operator safety mechanisms be connected and in proper operating condition prior to mower use.

When a problem occurs, do not overlook the simple causes. For example, starting problems could be caused by an empty fuel tank.

The following table lists some of the common causes of trouble. Do not attempt to service or replace major items or any items that call for special timing of adjustments procedures. Have this work done by your Engine Service Dealer.



PROBLEM	NO FUEL	IMPROPER FUEL	DIRT IN FUEL LINE	DIRTY AIR FILTER	FAULTY SPARK PLUG	ENGINE OVERLOADED	BLOCKED FUEL FILTER	INCORRECT OIL LEVEL	DIRTY AIR SCREEN
Will not Start	×		×	×	×	×	×		
Hard starting	×	×	×	×	×	×	×		
Stops suddenly	×		×	×	×	×	×	×	×
Lacks power		×	×	×	×	×	×	×	×
Operates erratically		×	×	×	×	×	×		×
Knock or pings		×				×			×
Skin or misfires		×	×	×	×				×
Backfires			×	×	×	×			×
Overheats			×	×		×		×	×
High fuel consumption				×	×	×			×



## 7、HYDRAULIC DIAGRAM

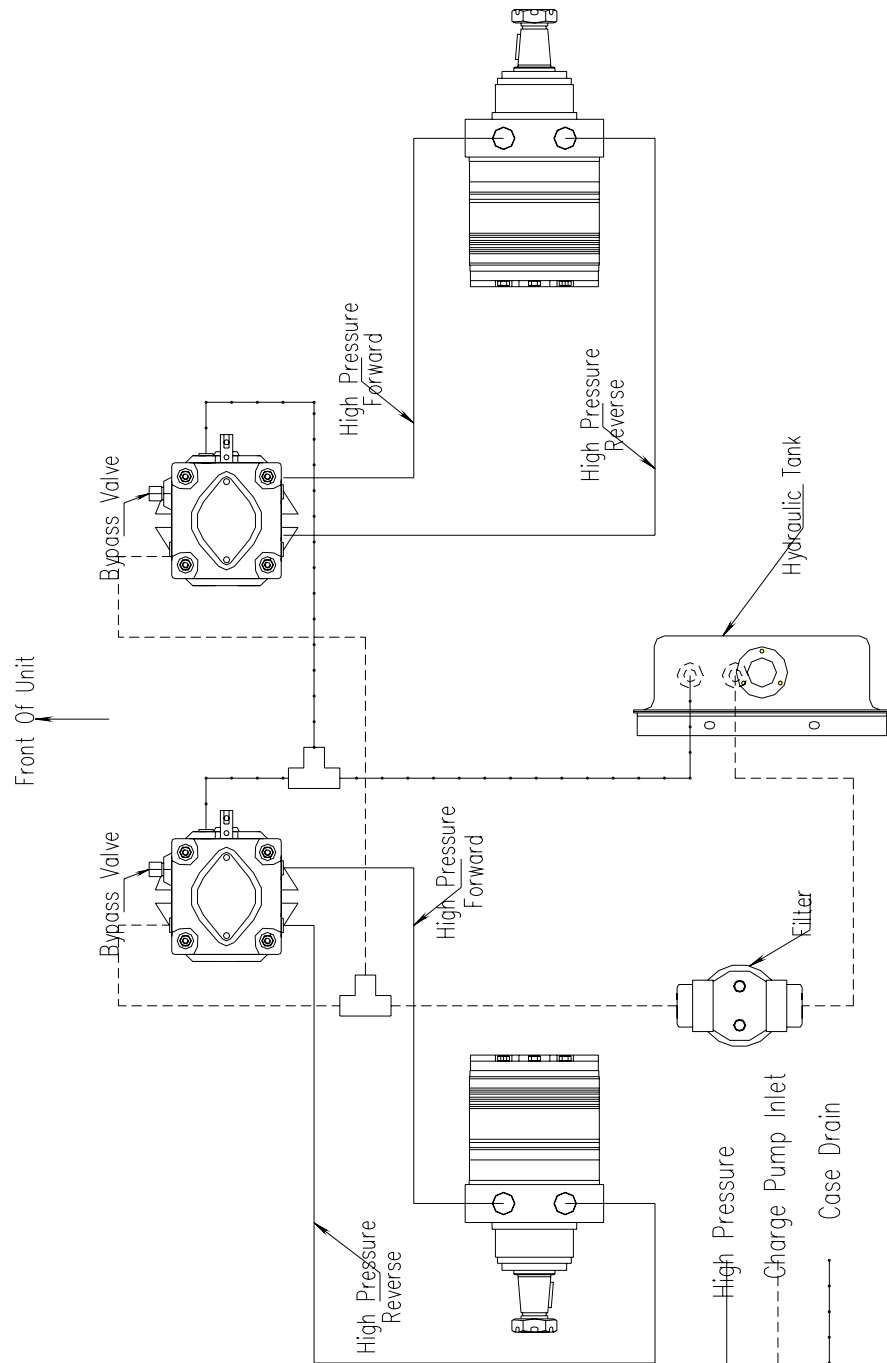

## 8. ELECTRICAL DIAGRAM

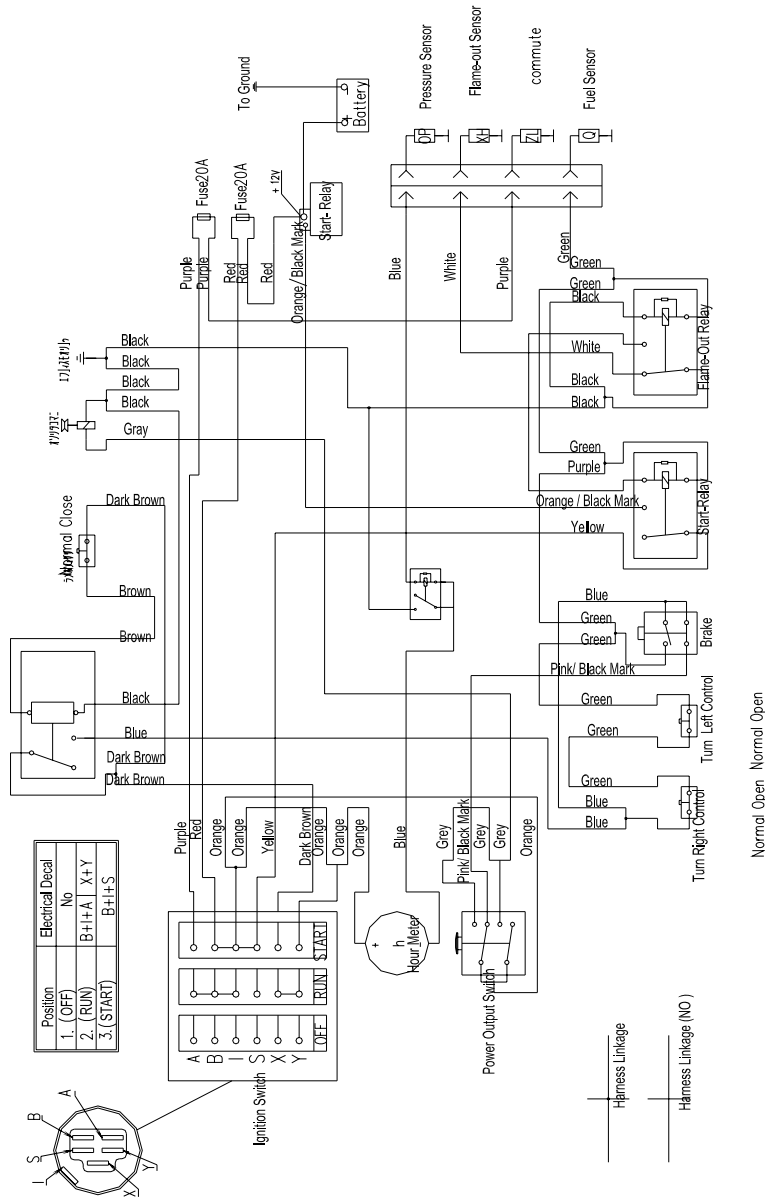



---

**LIMITED WARRANTY**  
**WORLDLAWN POWER EQUIPMENT, INC**  
**52/60" MOWER**

Worldlawn Power Equipment, Inc, ("Worldlawn") warrants that the worldlawn 52/60" Mower("Mower") will be free from defects in material and workmanship for a period of one year commercial from the original date of purchase. During the warranty period, Worldlawn will repair or replace, at its option, any Mower or part thereof which is found to be defective in material or workmanship. This warranty specifically excludes wear items, including but not limited to belts, blades and tires. This warranty also specifically excludes parts covered by another manufacturer's warranty, which parts are covered only by that manufacturer's warranty.

This limited warranty extends only to the original retail purchaser ("Owner") of a Mower. It is not transferable. This warranty extends only to those Mowers purchased for private residential and commercial use. A Mower purchased for any other reason, for example as a rental unit, shall have a ninety (90) day warranty under the same terms and conditions as set forth herein.

Proof of purchase will be required to substantiate all warranty claims. All warranty work must be performed by an authorized Worldlawn Dealer. Any work done on or to the Mower by anyone other than an authorized Worldlawn Dealer, including the original purchaser, voids all provisions of this warranty except those provisions which limit Worldlawn's liability (as set forth below).

Any Mower or part thereof which, in worldlawn's sole discretion, is deemed defective shall be repaired or replaced, at worldlawn's option, without charge for parts or labor. To take advantage of this warranty, the Mower must be returned to an authorized worldlawn Dealer within the warranty period. The cost of delivering the Mower to the authorized Dealer and return delivery shall be the responsibility of the Owner.

under this warranty is limited only to repairing or replacing the mower or a defective part thereof, and no claim of breach of warranty shall be cause for rescission, cancellation, or voiding the contract of sale of the Mower.

This warranty does not extend to any Mower or part thereof which has been misused, neglected, damaged, abused, not properly installed or maintained, altered or which has been operated in any way contrary to the operating instructions as specified in the Owner/Operator Manual. This warranty does not extend to any repair or replacement made necessary by normal use. This warranty does not extend to the engine which is warranted separately by the engine manufacturer.

THE WARRANTY EXPRESSED HEREIN IS IN LIEU OF OTHER WARRANTIES, EXPRESSED OR IMPLIED, INCLUDING, WITHOUT LIMITATION, ANY IMPLIED WARRANTY OR MERCHANTABILITY OR FITNESS FOR A PARTICULAR USE, AND IS IN LIEU OF ANY AND ALL OTHER OBLIGATIONS OR LIABILITY ON WORLDLAWN'S PART.

UNDER ANY AND ALL CIRCUMSTANCES, WORLDLAWN'S TOTAL LIABILITY TO OWNER FOR ANY AND ALL CLAIMS, LOSSES OR DAMAGES, INCLUDING LOSS OF PROFITS, ARISING OUT OF ANY CAUSE WHATSOEVER, WHETHER BASED IN CONTRACT, NEGLIGENCE OR OTHER TORT, STRICT LIABILITY, BREACH OF WARRANTY OR OTHERWISE, SHALL IN NO EVENT EXCEED THE PURCHASE PRICE OF THE MOWER. IN NO EVENT SHALL WORLDLAWN BE RESPONSIBLE FOR SPECIAL, INCIDENTAL, CONSEQUENTIAL OR EXEMPLARY DAMAGES



**WORLDLAWN®**

**Worldlawn Power Equipment, Inc.**

422 Turnbull Canyon Road, City of Industry, CA 91744

Phone:(626) 934-8552

Fax: (626) 934-8162

E-mail: [worldlawnmower@adelphia.net](mailto:worldlawnmower@adelphia.net)