

71495  
HGM-E SERIES GENERIC SERVICE SCHEMATIC

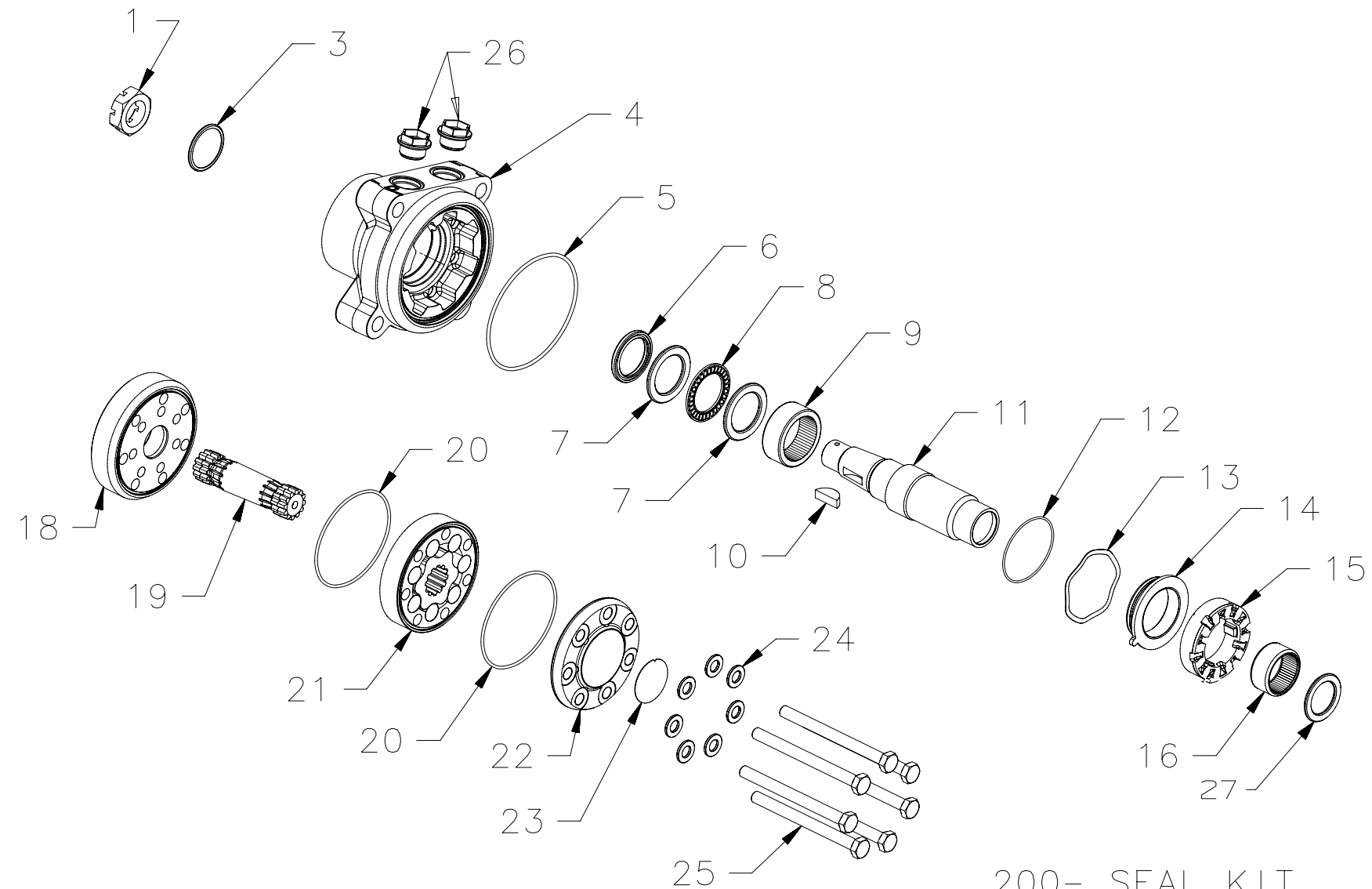

200- SEAL KIT  
201- BEARING KIT

# 71495 HGM-E SERIES GENERIC SERVICE SCHEMATIC

ITEM	PART #	QTY	DESCRIPTION
1	51821	1	NUT, CASTLE, 1-20 SLOTTED HEX
3	-----	1	DUST SEAL RING
4	-----	1	HOUSING
5	-----	1	O-RING
6	-----	1	OIL SEAL
9	-----	1	RADIAL NEEDLE BEARING 42 X 52 X 20 mm
10	51796	1	KEY, WOODRUFF 5/16 X 1
11	-----	1	SHAFT TAPERED (35 mm) 1 1/4 INCH
12	-----	1	O-RING
13	-----	1	SPRING WASHER 58 X 67 X 0.5 mm
14	-----	1	BALANCE PLATE
15	-----	1	DISC VALVE
16	-----	1	RADIAL NEEDLE BEARING 35 X 42 X 20 mm
18	-----	1	DISTRIBUTOR PLATE
19	-----	1	CARDAN SHAFT - OMEW 100-100 L= 101.4 mm
20	-----	2	O-RING
21	-----	1	GEARWHEEL SET-OMEW 100-100 W = 14.0 mm
22	-----	1	END COVER
23	-----	1	NAME PLATE
24	-----	7	WASHER
25	-----	7	SCREWS - OMEW 100 - M8 X 85 MM
26	-----	2	PLUG, G 1/2 (7/8-14UNF SAE)
200	SEE CHARTS	1	KIT, SEAL HGM E-SERIES
201	SEE CHART	1	KIT, AXIAL NEEDLE BEARING HGM E-SERIES

PRIOR TO SERIAL # 5040N10001		
HGM MODELS: HGM-10E-3058, 3059; 12E-3050, 3054; 15E-3051, 3055; 18E-3052, 3056; 24E-3053, 3057		
ITEM #	H-G P/N	DESCRIPTION
200	70602-1	SEAL KIT

CONTAINS:				
ITEM	PART #	QTY	DESCRIPTION	
3	-----	1	DUST SEAL RING	
5	-----	1	O-RING	
6	-----	1	OIL SEAL	
12	-----	1	O-RING	
20	-----	2	O-RING	
24	-----	7	WASHER	

AFTER SERIAL # 5040N10001 OR SERIAL # BEGINNING WITH "L"		
HGM MODELS: HGM-10E-3058, 3059; 12E-3050, 3054; 15E-3051, 3055; 18E-3052, 3056; 24E-3053, 3057		
ITEM #	H-G P/N	DESCRIPTION
200	70602-2	SEAL KIT

CONTAINS:				
ITEM	PART #	QTY	DESCRIPTION	
3	-----	1	DUST SEAL RING	
5	-----	1	O-RING	
6	-----	1	OIL SEAL	
12	-----	1	O-RING	
20	-----	2	O-RING	
24	-----	7	WASHER	

ALL HGM MODELS		
ITEM #	H-G P/N	DESCRIPTION
201	71494	KIT, AXIAL NEEDLE BEARING HGM E-SERIES

CONTAINS:				
ITEM	PART #	QTY	DESCRIPTION	
7	-----	2	BEARING RACE 35 X 52 X 3.5mm	
8	-----	1	BEARING, AXIAL NEEDLE 35 X 52 X 3mm	
9	-----	1	RADIAL NEEDLE BEARING 42 X 52 X 20mm	
16	-----	1	RADIAL NEEDLE BEARING 35 X 42 X 20mm	
27	-----	1	BEARING, GLACIER WASHER 29 X 42 X 1.5mm	

HGM MODELS: HGM-12E-3131; 15E-3132 AND 15E-3138		
ITEM #	H-G P/N	DESCRIPTION
200	70602-3	SEAL KIT

CONTAINS:				
ITEM	PART #	QTY	DESCRIPTION	
3	-----	1	DUST SEAL RING	
5	-----	1	O-RING	
6	-----	1	OIL SEAL	
12	-----	1	O-RING	
20	-----	2	O-RING	
24	-----	7	WASHER	

