

DIAMONDBACK/EDGE

GRASS COLLECTION SYSTEM

PARTS & OPERATORS MANUAL

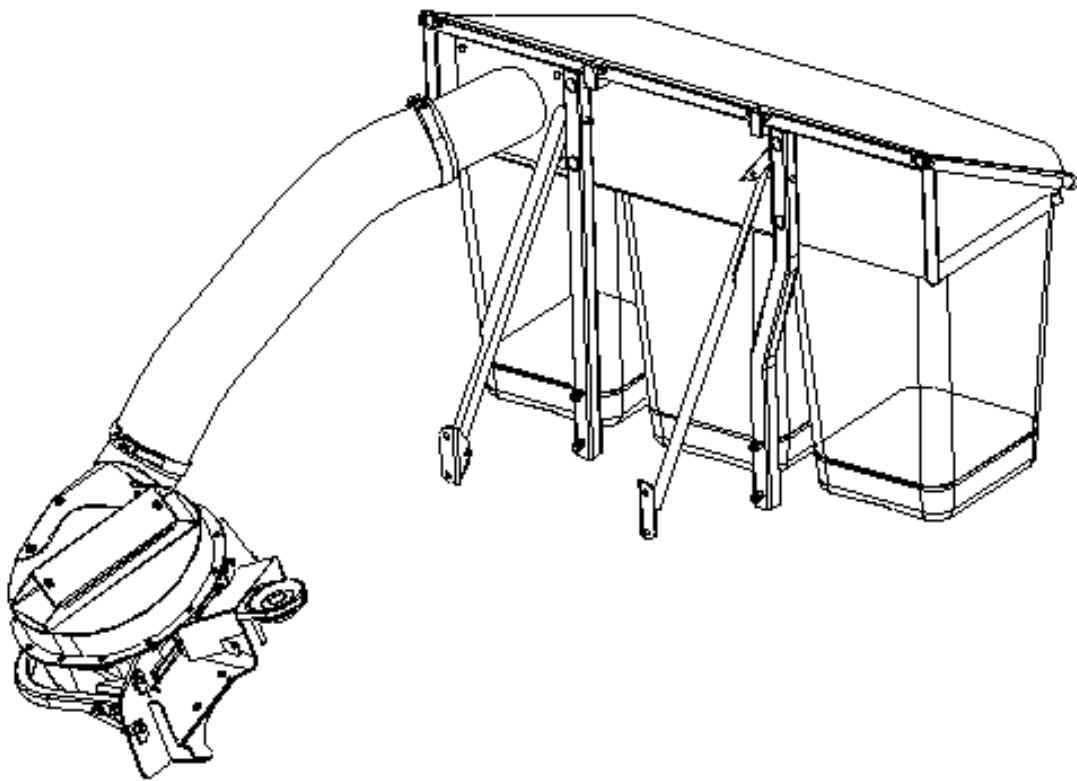

GRASS CATCHER W/WEIGHT:

48" 5101305
52" 5101305
60" 632086

TUBE KIT:

632093
542119
542120

BLOWER KIT:

632078
632074
632081

WORLDLAWN POWER EQUIPMENT, INC.

401 COMMERCE STREET

BEATRICE, NE 68310

800-267-4255

FAX – 402-223-4103

OPERATORS MANUAL

Before operating the catcher assembly, read this manual in its entirety.

Keep this Owner's Manual when lent or transferred.

If this Operator's Manual is lost, damaged or illegible, replace it immediately. Replacements may be ordered through our sales department or our dealers. If additional information is needed, contact our sales department or a dealer. Always give the model number and serial number for the mower and the bagger. To improve the quality, performance and security we may make changes to our products.

WARNING

POTENTIAL HAZARD

- This product is a piece of power equipment.

WHAT CAN HAPPEN

- Failure to follow safe operating practices can result in serious operator injury or even death.

HOW TO AVOID THE HAZARD

- Keep all shields, guards and safety devices (especially the grass discharge system) in place and in proper working condition.
- Stop machine and wait for all moving parts to stop, remove spark plug wires or remove key before adjusting, servicing, or performing maintenance.
- If mower deck becomes clogged, stop machine and wait for all moving parts to stop. Remove spark plug wire or remove key before cleaning blockage.
- Keep hands, feet, and clothing away from power driven parts.
- Keep others off mower.

CONTENTS

SAFETY	8
SAFETY AND INSTRUCTION DECALS	9
INSTALLING GRASS COLLECTION SYSTEM.....	9
Unpacking	9
Install Drive Pulley.....	9
Install the grass discharging system	10
Install Grass Catcher Tubes.....	11
Install the Quick Attach Bracket & Gussets	11
Assemble Grass Catcher Frame.....	11
Attach Grass Catcher System.....	12
Bag Installation.....	12
Installing Belt Cover	12
Install Grass Tube	13
Install Weights.....	13
OPERATION	14
Controls	14
Emptying the Grass Bags	14
Cleaning Obstruction from the Bagger System.....	15
Transporting Machines.....	15
Operating Tips.....	15
MAINTENANCE & ADJUSTMENT	16
Recommended Maintenance Schedule	16
Clean the debris	16
Replace the belt	16
Replace the bag	16
ADJUSTMENT	17
STORAGE.....	17
TROUBLESHOOTING	18
PARTS CATALOG	19
CATCHER.....	19
BLOWER ASSEMBLY	21
IDLER ARM ASSEMBLY	23
DISCHARGE CHUTE ASM.....	24
HOOD ASSEMBLY	25
GRASS CATCHER ASSEMBLY	27
WEIGHT KIT ASSEMBLY	29
GRASSBAG ASSEMBLY.....	30

SAFETY

The following list contains safety information specific to WORL DLAWN products and other safety information you must know.

- a) Read the instructions carefully. Become familiar with the safe operation of the equipment, operator controls, and safety signs.
- b) All operators need to be trained before operating this unit.
- c) Never let children or untrained people operate the equipment without proper instruction.
- d) Keep everyone, especially children and pets, away from the area of operation. Remember that the operator or user is responsible for accidents or hazards occurring to other people or their property.
- e) Do not use a grass catcher on steep slopes. A heavy grass catcher could cause loss of control or overturn the machine.
- f) Keep all movement on slopes slow and gradual. Do not make sudden changes in speed, direction or turning.
- g) The grass catcher can obstruct the view to the rear. Use extra care when operating in reverse.
- h) Keep hands and feet away from moving parts. Do not make adjustments with the engine running.
- i) Do not leave grass in grass catcher for extended periods of time.
- j) Grass catcher components are subject to wear, damage and deterioration, which could expose moving parts or allow object to be thrown. Frequently check components and replace with manufacturer's recommended parts, when necessary.
- k) Stop the engine before removing the grass catcher or unclogging the chute.

SAFETY ALERT SYMBOL

This symbol means: **ATTENTION! BECOME ALERT! YOUR SAFETY IS INVOLVED!**



The safety alert symbol appears above information which alerts you to unsafe actions or situations and will be followed by the word **DANGER, WARNING, or CAUTION.**



DANGER: White lettering/Red background.

Indicates an imminently hazardous situation which, if not avoided, will result in death or serious injury.



WARNING: Black letters on orange background.

Indicates a potentially hazardous situation which, if not avoided, could result in death or serious injury.



CAUTION: Black letters on yellow background.

Indicates a potentially hazardous situation which, if not avoided, may result in minor or moderate injury. It may also be used to alert against unsafe practices

SAFETY AND INSTRUCTION DECALS



8304



8045



8350

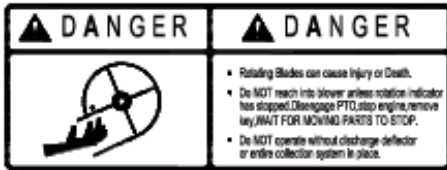

8351



8352

INSTALLING GRASS COLLECTION SYSTEM

Note: The part numbers in the following assembly procedures are consistent with those in the parts catalog.

Unpacking

- Open Crate.
- Remove loose parts (i.e., Operator's manual, etc.) from crate.
- Remove unit from crate, check crate thoroughly for loose parts.

Install Drive Pulley

- a) Remove the side discharge chute, bushing, and belt cover (FIG 1) from the mower deck.
- Note:** Keep the unused parts in a bag for later use.

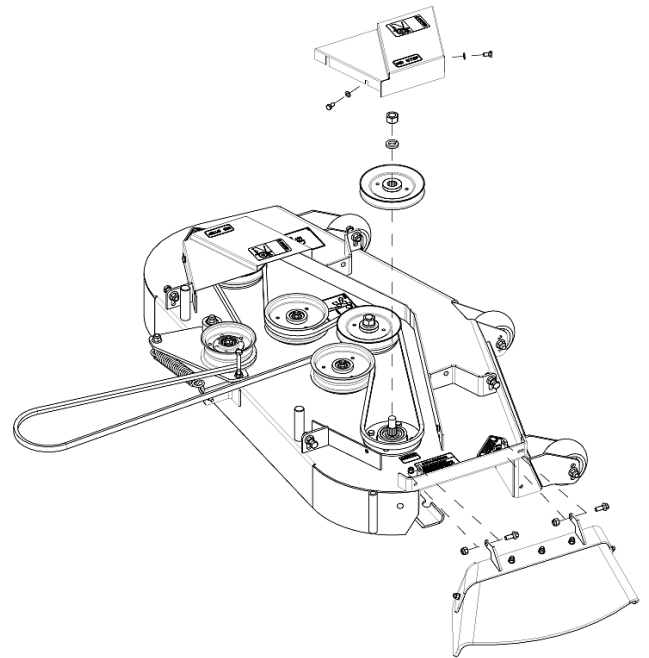

FIG 1

b) Install Drive Pulley (FIG 2) using existing hardware

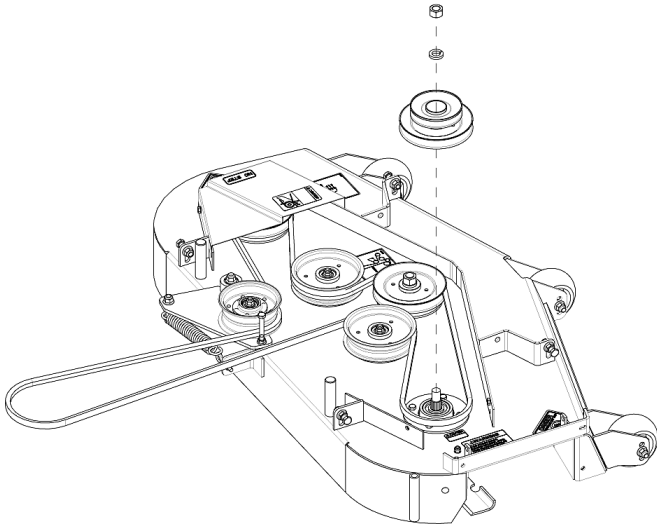

FIG 2

Note: Part no. 6 is equipped with the ZTR mower.
Torque no. 6 to 115-120 ft/lbs

Install the grass discharging system

a) Install the blower

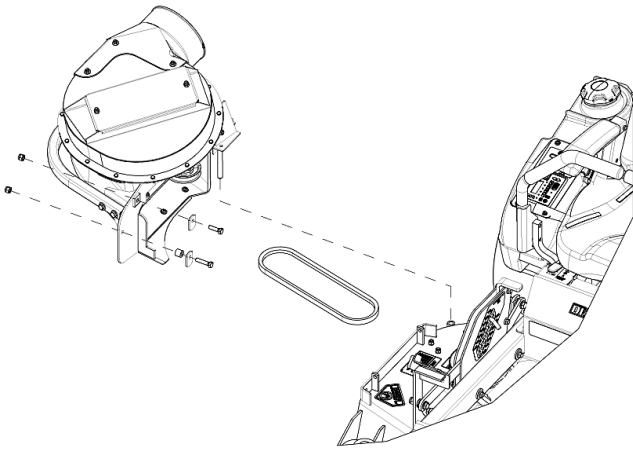
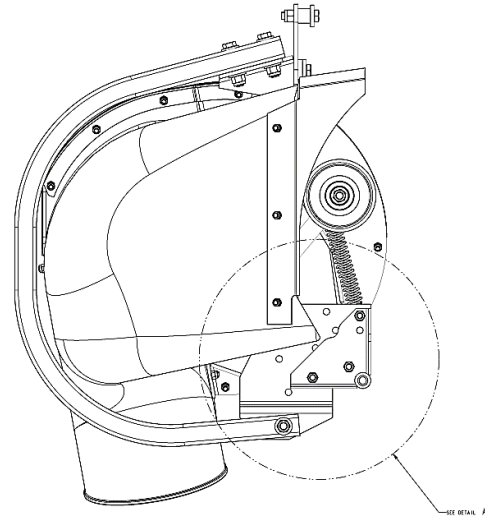

FIG 3

b) Install the tension assembly arm and belt

c) Proper Axle Pin attachment locations:



48" Bolt Pattern:

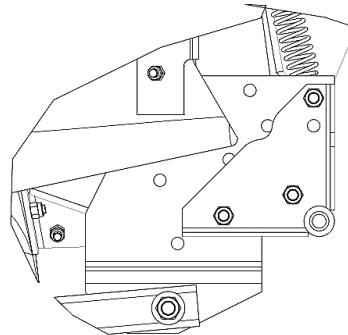

52" Bolt Pattern:

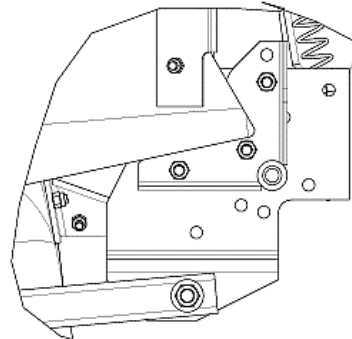

60" Bolt Pattern:

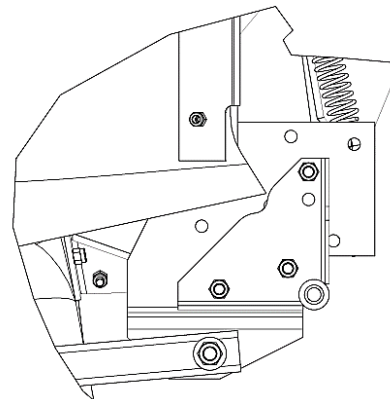

Install Grass Catcher Tubes

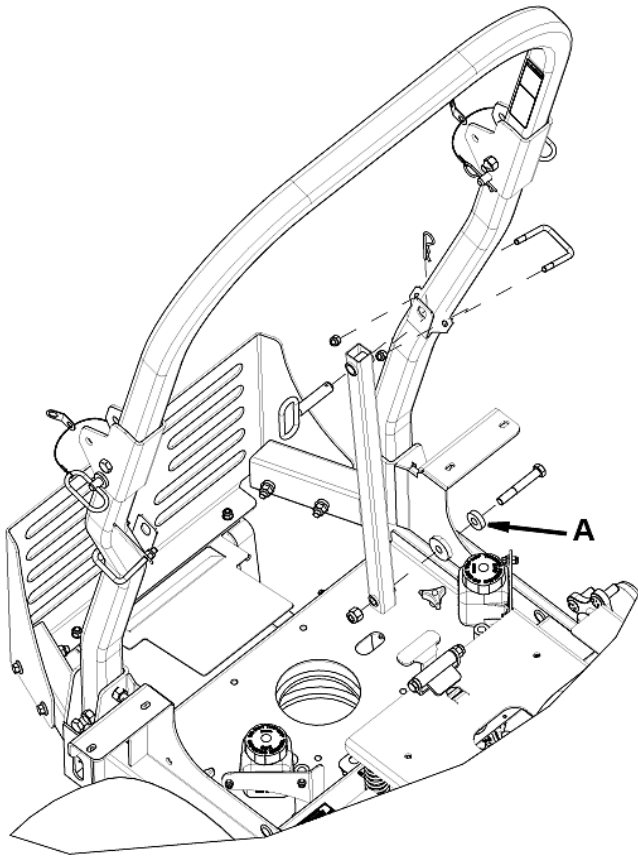

FIG 4

Install grass catcher tubes as shown above
Spacer (A) may need to be placed inside of frame
to increase clearance between tube & ROPS
pocket.

Install the Quick Attach Bracket & Gussets

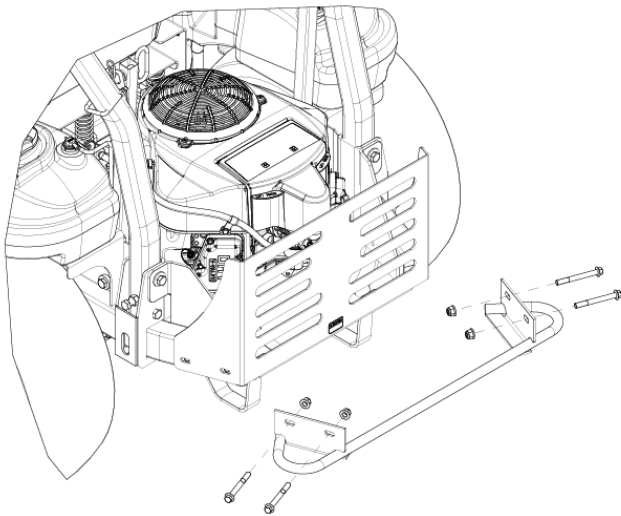
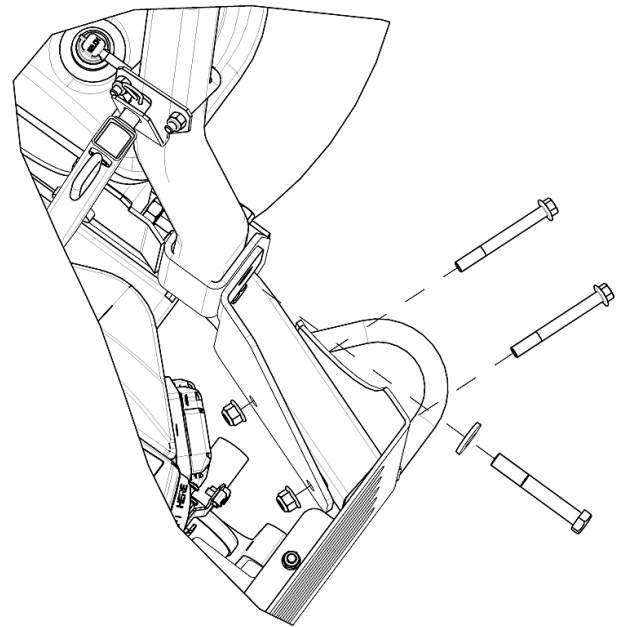

FIG 5



Assemble Grass Catcher Frame

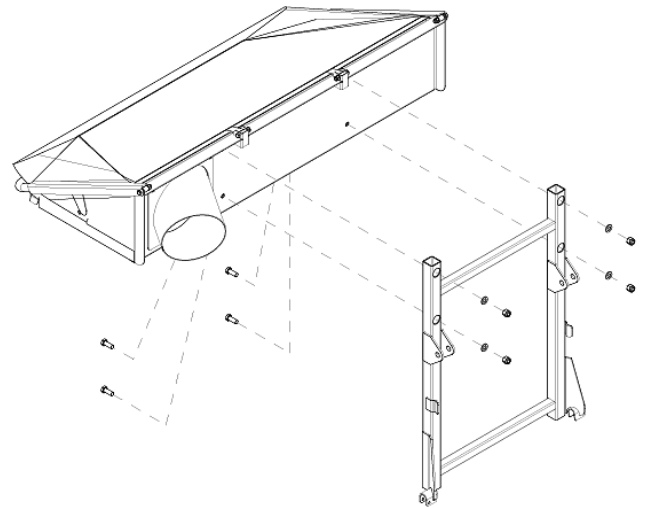

FIG 6

a) Attach Hood to Grass Catcher Frame

Attach Grass Catcher System

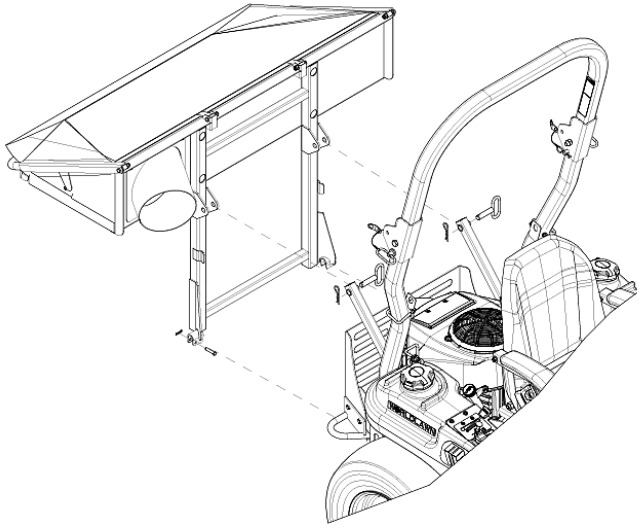

FIG 7

- a) Install grass catcher system to quick attach bracket
- b) Attach support tubes with the pins to support tubes

Bag Installation

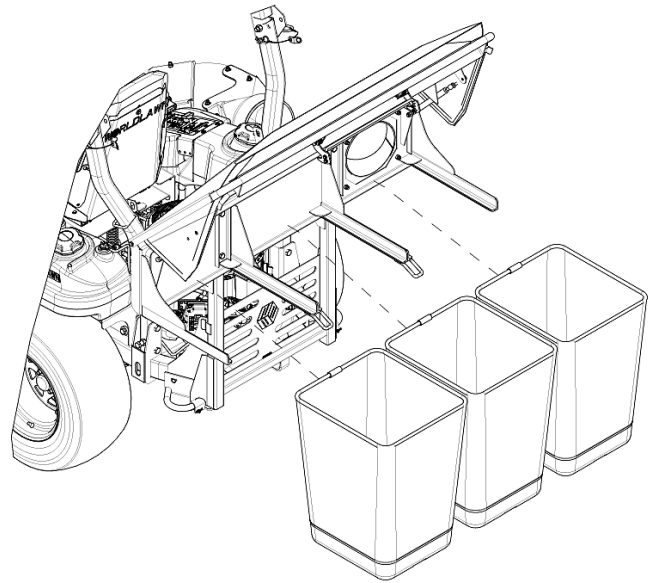

FIG 8

- a) Install bags with collar section toward the unit

Installing Belt Cover

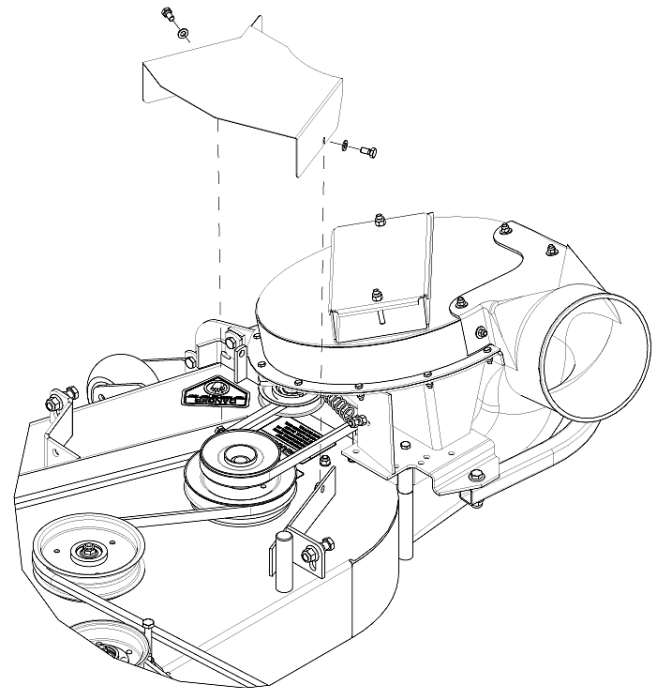

FIG 9

Install Grass Tube

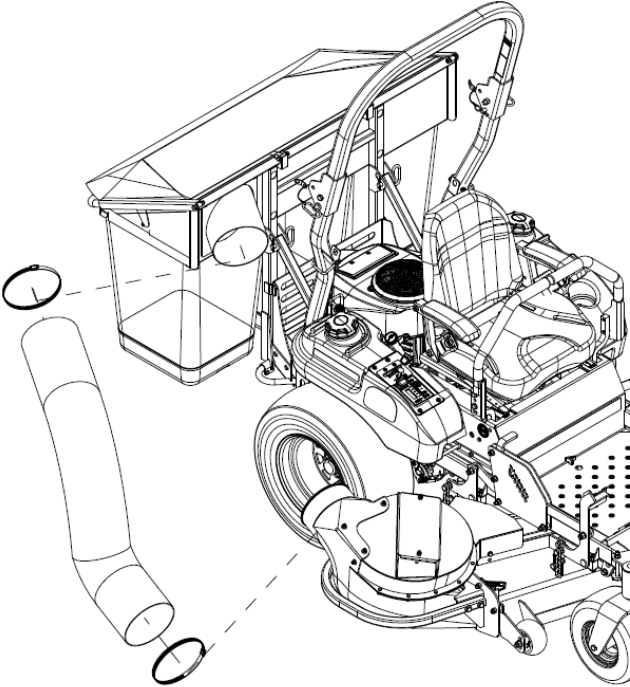

FIG 10

Install Weights

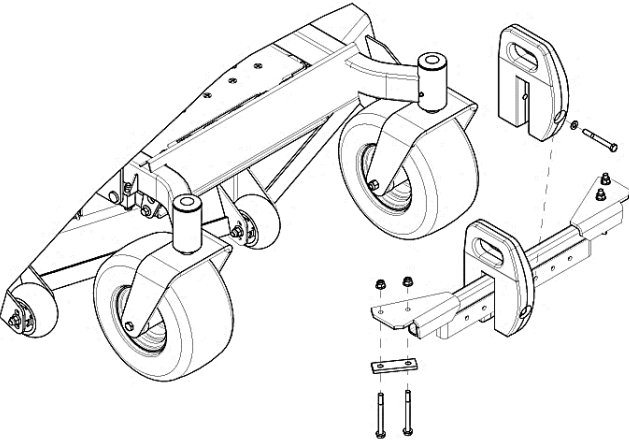

FIG 11

OPERATION

Controls

- 1) Familiarize yourself with all controls before operating the mower.
- 2) Keep a safe working area.
- 3) Always remove the ignition key and set the parking brake when leaving the machine unattended, even if just for a few minutes.
- 4) Children or bystanders may be injured if they move or attempt to operate the mower when it is unattended.

WARNING

POTENTIAL HAZARD

- Not being aware of working area.
- Not shutting off engine and setting the parking brake while it is unattended.
- Children or bystanders attempt to operate the mower.

WHAT CAN HAPPEN

- Bystanders may be injured while moving forward, backward or turning around.
- Children or bystanders may be injured if they move or attempt to operate the mower while it is unattended.

HOW TO AVOID THE HAZARD

- Keep a safe working area.
- Always remove the ignition key and set the parking brake when leaving the machine unattended, even if just for a few minutes.
- Children or bystanders are not allowed to operate.

Emptying the Grass Bags

Grass bags are heavy when full. Be careful when lifting or handling a grass bag that is full.

- 1) Disengage the PTO, set the parking brake, and chock or block the tires if on a slope.
- 2) Unlatch the bagger latch, and open the bagger hood.
- 3) Compress the debris into the bags. With both hands, lift up on the bag and unhook it from the bagger bracket.
- 4) Grasp the handle on the bottom of the bag and tip it over to empty the bag.
- 5) Clean off the grass from the bracket, especially the notch in the bracket.
- 6) Replace bag by sliding it completely into proper position.

WARNING

POTENTIAL HAZARD

- Opening the hood as engine is running
- Dumping grass on a slope.
- Grass bag is heavy when full
- Grass buildup in the notch of the bagger bracket.

WHAT CAN HAPPEN

- Opening the hood while engine is running, may cause injury due to flying debris.
- Even with park brake set unit may slip on slope due to weight of full bags
- You will be hurt when lifting the fully loaded bag.
- The bag is not fully in position and the hood cannot be latched

HOW TO AVOID THE HAZARD

- Turn off the engine, waiting for all moving parts to stop before leaving the operating position.
- Using a stick or similar object to obstruct the wheel on a slope.
- Lift the bag using both hands
- Clean grass from the bracket, especially the notch in the bagger bracket.

Cleaning Obstruction from the Bagger System

- 1) Disengage the PTO and set the parking brake.
- 2) Turn off the engine, remove the key, and wait for all moving parts to stop.
- 3) Empty the bags.
- 4) Unlatch the lower tube.
- 5) Use a long object, not your hands, to remove an obstruction.

CAUTION

POTENTIAL HAZARD

- Raising the rear of the unit relying solely on jacks could be dangerous.

WHAT CAN HAPPEN

- The jacks may not be enough support or may malfunction allowing the unit to fall, which could cause injury.

HOW TO AVOID THE HAZARD

- DO NOT rely solely on the jacks for support. Use adequate jack stands or equivalent support.

Transporting Machines

Do not leave grass or debris in the bagger while transporting the machine

WARNING

POTENTIAL HAZARD

- Leave grass or debris in the bagger while transporting the machine.

WHAT CAN HAPPEN

- Transporting the machine with grass or debris in the bagger can damage the machine.

HOW TO AVOID THE HAZARD

- Do not leave grass or debris in the bagger while transporting the machine.

Operating Tips

- 1) Remember that the machine is longer and wider with this attachment installed. By turning too sharply in confined places you may damage the attachment or the other property.
- 2) Always trim with the left side of the mower
- 3) Cut the grass often, especially when it grows rapidly. For best cutting appearance,

be sure to slightly overlap the mower into the previously cut area. This helps reduce the load on the engine and reduce the chance of plugging the blower assembly and tubes.

CAUTION

POTENTIAL HAZARD

- Cutting tall grass, and moving forward too fast.

WHAT CAN HAPPEN

- Plug the blower assembly

HOW TO AVOID THE HAZARD

- When the grass is too long, be sure cut it several times and move slowly.

- 4) If the grass is ever allowed to grow longer than normal or if it contains a high degree of moisture raise the cutting height higher than usual and cut and bag the grass at that setting. Then cut and bag the grass again, using the lower normal setting. Excessively long grass is heavy and may not be propelled completely into the bagger.
- 5) If possible, always try to cut grass when it is dry. Wet grass can cause plugging.
- 6) To avoid plugging the bagging system, reduce ground speed and mow the grass at a high height of cut, then lower the mower to your normal cutting height and repeat the bagging process.
- 7) As you are bagging, small amounts of grass clipping normally blow out the front of the mower. An excessive amount of clipping blow-out indicates that the bagger is full or the tube is plugged.
- 8) Always lift the deck to the highest position when loading the machine on trailer or ascending/descending a curb.

MAINTENANCE & ADJUSTMENT

WARNING

POTENTIAL HAZARD

- Engine is started when making the adjustment.

WHAT CAN HAPPEN

- May result in serious injury, death.

HOW TO AVOID THE HAZARD

- Before adjustment, remove the key.

WARNING

POTENTIAL HAZARD

- Engine is overheating.

WHAT CAN HAPPEN

- Severe burns can occur on contact.

HOW TO AVOID THE HAZARD

- Allow engine parts, especially the muffler, to cool before touching.

Recommended Maintenance Schedule

Maintenance Service Interval	Maintenance Schedule
After the first 6 operating hours	<ul style="list-style-type: none"> Inspect the belt
Before each use or daily	<ul style="list-style-type: none"> Clean the blower assembly Clean the bagger system Clean the bags
Every 25 hours	<ul style="list-style-type: none"> Inspect the belt

Clean the debris

Maintenance interval: Daily

Turn off the engine, remove the key, and wait for all moving parts to stop

- 1) Raise the front of the unit and support it with jack stands or equivalent support to the transportation position

CAUTION

POTENTIAL HAZARD

- Raising the front of the unit relying solely on jacks could be dangerous.

WHAT CAN HAPPEN

- The jacks may not be enough support or may malfunction allowing the unit to fall, which could cause injury.

HOW TO AVOID THE HAZARD

- DO NOT rely solely on the jacks for support. Use adequate jack stands or equivalent support.

- 2) Clean the debris from underside of the mower and in the blower assembly.
- 3) Wash the inside and outside of the bagger hood, bags, tube and the underside of the mower.
- 4) After washing all the parts, let them dry thoroughly and re-install.
- 5) With all parts installed, start and run the machine for a minute to assist in drying.

Replace the belt

- 1) Disengage to PTO, move the motion control levers to the neutral locked position, and set the parking brake.
- 2) Stop the engine, remove the key and wait for all moving parts to stop before leaving the operating position.
- 3) Remove the belt cover and relieve the belt tension
- 4) Replace the new belt.
- 5) Adjust the belt pulley and the reinstall the belt cover.

Replace the bag

- 1) Disengage the PTO, move the motion control levers to the neutral locked position and set the parking brake.
- 2) Stop the engine, remove the key and wait for all moving parts to stop before leaving the operating position.
- 3) Unlock the bagger frame
- 4) Slide out the bag along the bagger frame locking position.
- 5) Replace with new bag.

ADJUSTMENT

Deflector Adjustment

Deflector can fill the three bags evenly if adjusted properly.

- 1) Empty the three bags
- 2) Cut grass for approximately three minutes
- 3) Disengage the PTO, move the motion control levers to the neutral locked position and set the parking brake.
- 4) Stop the engine, remove the key and wait for all moving parts to stop before leaving the operating position.
- 5) Open the hood, check the level of fill in the three bags
- 6) Adjust the deflector position according to the grass levels in the bag.
- 7) Repeat procedure 2-6 times until the grass level in the three bags are even.

NOTE: The catcher fill of the three bags can't be 100% the same.

STORAGE

- a) Clean the bagger attachment. Refer to cleaning the bagger
- b) Inspect the bagger attachment for damage.
- c) Make sure the bags are empty and thoroughly dry.
- d) Store the machine in a clean, dry place, out of direct sunlight. If you must store the machine outside, cover it with a weatherproof cover. This protects the plastic parts and extends the life of the machine.

TROUBLESHOOTING

Problem	Possible Cause	Corrective Action
Abnormal vibration	<ul style="list-style-type: none"> • Cutting blades are bent or unbalanced • Loose blower pulley or pulley assembly 	<ul style="list-style-type: none"> • Install new cutting blade • Tighten the pulley
Reduced bagging performance	<ul style="list-style-type: none"> • Low engine speed • Plugged screen in bagger hood • Loose bagger belt • Full bags 	<ul style="list-style-type: none"> • Always operate the bagger at full throttle • Remove debris, leaves or grass clippings from the screen • Replace the bagger belt • Empty the hopper
Blower and tubes plug too frequently	<ul style="list-style-type: none"> • Bags are too full • Low engine speed • Grass is too wet • Grass is too long • Ground speed is too fast • Worn bagger belt • Loose bagger belt 	<ul style="list-style-type: none"> • Dump more frequently • Always operate the bagger at full throttle • Cut grass when it is dry • Cut the grass several times • Drive slower at full throttle • Replace belt • Adjust the pulley, tighten belts
Debris blowout	<ul style="list-style-type: none"> • Bags are too full • Plug in the bagger system • Ground speed is too fast 	<ul style="list-style-type: none"> • Dump more frequently • Clean the bagger system • Drive slower at full throttle
Impeller can't rotate freely	<ul style="list-style-type: none"> • Plug in the blower system • Worn impeller 	<ul style="list-style-type: none"> • Clean the blower system • Contact dealer to replace

PARTS CATALOG

CATCHER

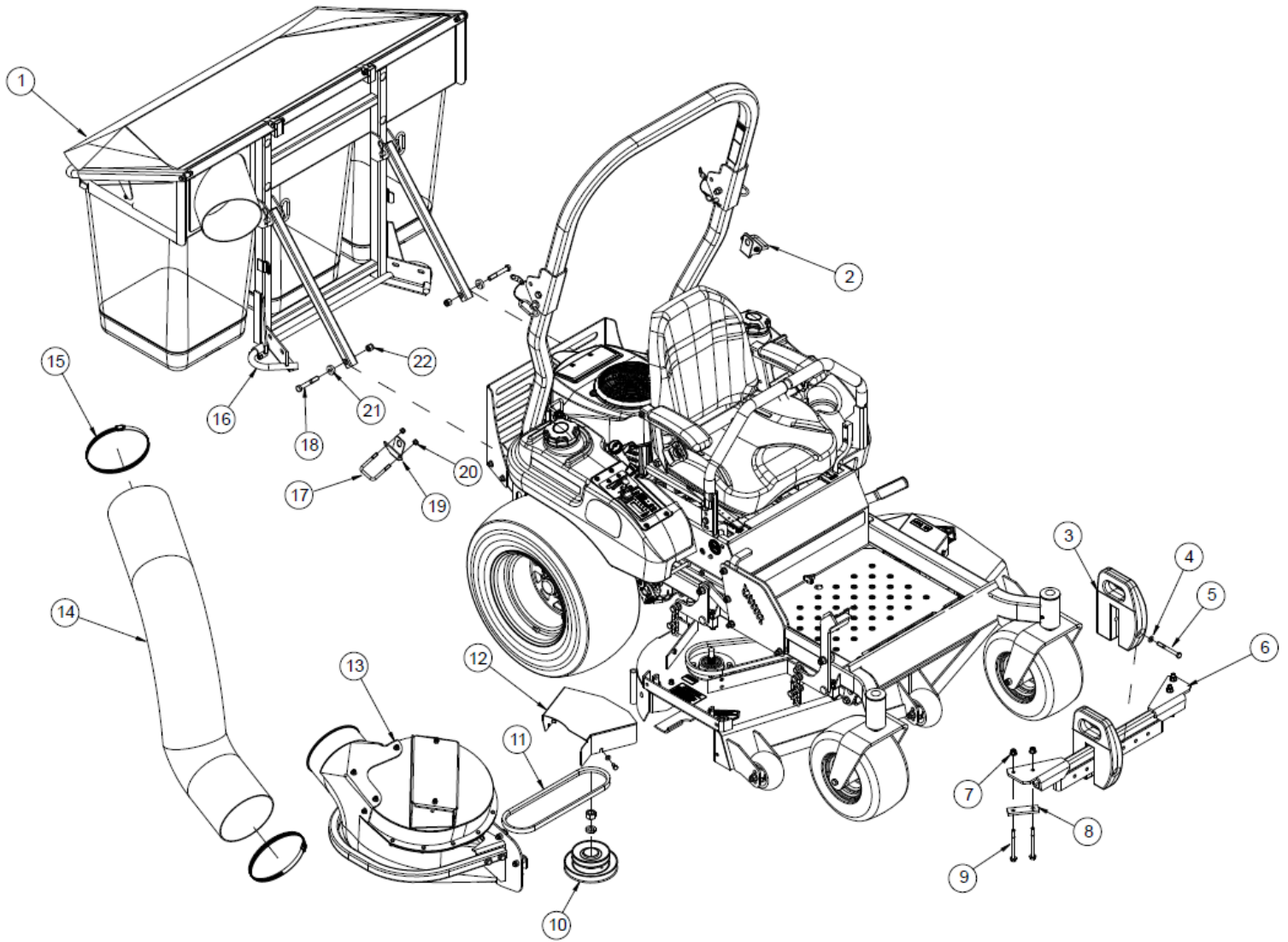

CATCHER

ITEM	PART NO.	DESCRIPTION
1	5101200	ASM, GRASS CATCHER
2	5101325	ASM, SUPPORT BRACKET
3	5101251	WEIGHTS
4	B97.1-10	WASHER, FLAT M10
5	B5782-1090	BOLT M10 X 90
6	5101350	ASM, DB FRONT WEIGHT KIT – 48” & 52”
	632085	ASM, DB 60 FRONT WEIGHT KIT
7	B6183-10	NUT, NYLOC FLANGE M10
8	5101252	MOUNTING PLATE
9	B5782-10110	BOLT M10 X 110
10	632079	WLD, DB 48 BLOWER DOUBLE PULLEY
	5101370	WLD, DB 52” BLOWER DOUBLE PULLEY
	632082	WLD, DB 60 BLOWER DOUBLE PULLEY
11	633254	BELT, BLOWER 48
	543451	BELT, BLOWER 52
	543452	BELT, BLOWER 60
12	632084-1	WLD, DB 48 BLOWER BELT SHIELD
	5101375	WLD, DB 52 BELT GUARD
	632083-1	WLD, DB 60 BLOWER BELT SHIELD
13	632078	ASM, DB 48 BLOWER W/DECALS
	632074	ASM, DB 52 BLOWER W/DECALS
	632081	ASM, DB 60 BLOWER W/DECALS
14	543453	TUBE, GRASS COLLECTION 4.5FT
15	153048	6” QUICK RELEASE CLAMP
16	5101320	DB GC QUICK ATTACH BRACKET
17	5101327	U-BOLT, M8 X 1.25
18	B5782-1280	SCREW, HH M12 X 80
19	5101326	BRACKET, SUPPORT
20	B6182-8	NUT, NYLOC M8
21	5101311	SPACER
22	B6182-12	NUT, NYLOC M12

BLOWER ASSEMBLY

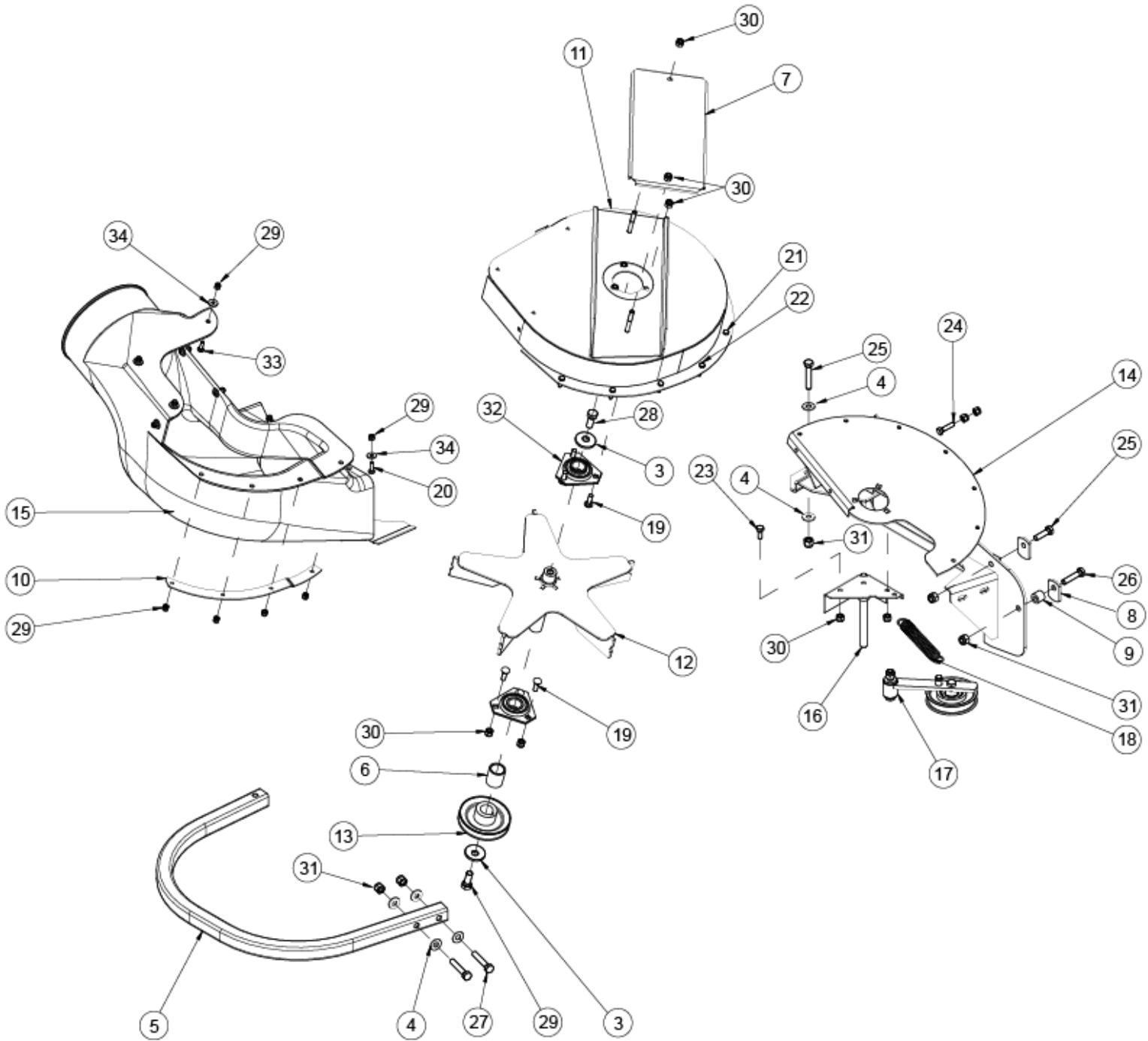

BLOWER ASSEMBLY

ITEM	PART NO.	DESCRIPTION
1	8350	DECAL, DISCHARGE WARNING
2	8351	DECAL, ROTATING BLADES DANGER
3	3302008	DISC SPRING WASHER
4	3302058	WASHER 10
5	5101022	BUMPER
6	5101023	BUSHING
7	5101024	COVER
8	5101025	PANEL
9	5101026	BUSHING
10	5101027	MULCHING PLATE
11	5101120	UPPER COVER
12	5101130	IMPELLER WLD
13	5101135	BLADE PULLEY
14	5101140	FAN COVER
15	5101155	48" & 52" DISCHARGE CHUTE ASM
	5101165	60" DISCHARGE CHUTE ASM
16	5101160	AXLE PIN WLD
17	5101170	ASM, IDLER ARM SEE DETAIL ON PG 19
18	5210417	TENSION SPRING
19	B12-825	SQUARE BOLT M8 X 25
20	B2672-620	SCREW M6 X 20
21	B5783-620	SCREW, HH TAP M6 X 20
22	B5783-625	BOLT M6 X 25
23	B5783-820	SCREW, HH TAP M8 X 20
24	B5783-830	SCREW, HH TAP M10 X 35
25	B5783-1035	SCREW, HH TAP M 10 X 35
26	B5783-1045	BOLT M10 X 45
27	B5783-1055	SCREW, HH TAP M10 X 55
28	B5783-1230	BOLT M 12 X 30
29	B6182-6	NUT, NYLOC M6
30	B6182-8	NUT, NYLOC M8
31	B6182-10	NUT, NYLOC M10
32	B7810-UBPFT205	BEARING
33	B801-620	CARRIAGE BOLT M6 X 20
34	B96-6	WASHER, FLAT LARGE M6

IDLER ARM ASSEMBLY

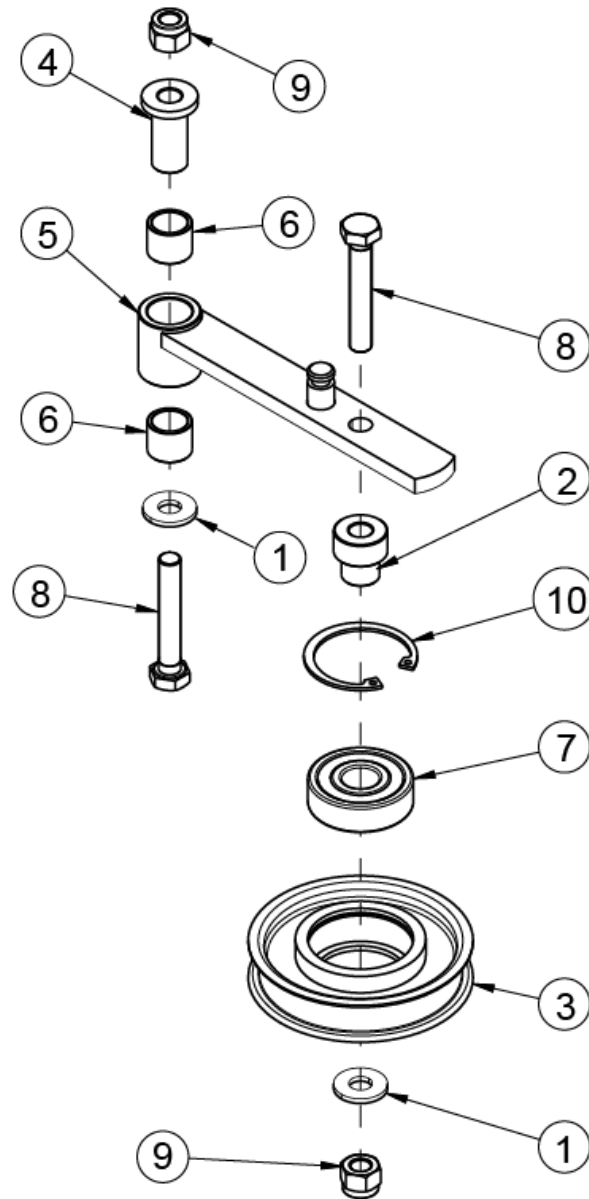

ITEM	PART NO.	DESCRIPTION
1	3302058	WASHER 10
2	5002161	BUSHING
3	5002175	TETNSION PULLEY
4	5101171	BUSHING
5	5101175	TENSION ARM WLD
6	B2685-162016	BEARING 16 X 20 X 16
7	B276-6303RS	BEARING 6303-2RS
8	B5783-1060	BOLT M10 X 60
9	B6182-10	NUT, NYLOC M10
10	B893.2-47	SNAP RING 47

DISCHARGE CHUTE ASM

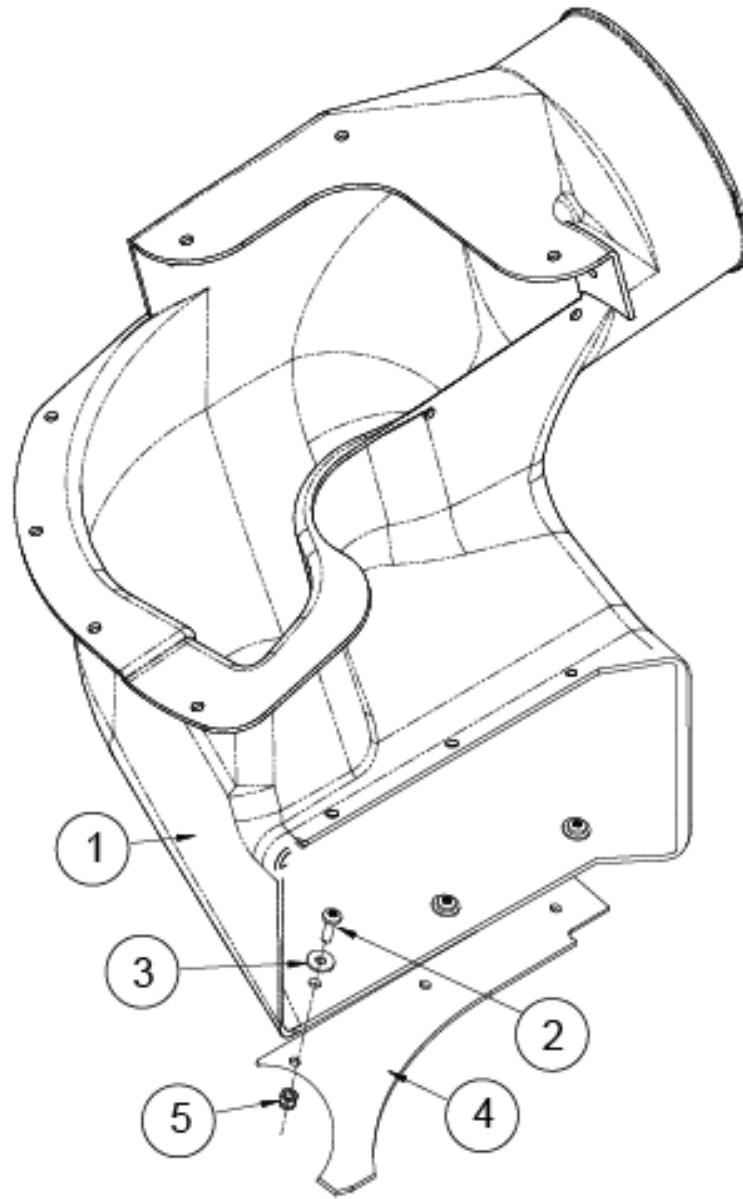

ITEM	PART NO.	DESCRIPTION
1	5101155	52" DISCHARGE CHUTE ASM, COMPLETE
	5101165	60" DISCHARGE CHUTE ASM, COMPLETE
2	B2672-620	SCREW M6 X 20
3	B96-6	WASHER, FLAT LARGE M6
4	5101156	MULCHING PLATE
5	B6182-6	NUT, NYLOC M6

HOOD ASSEMBLY

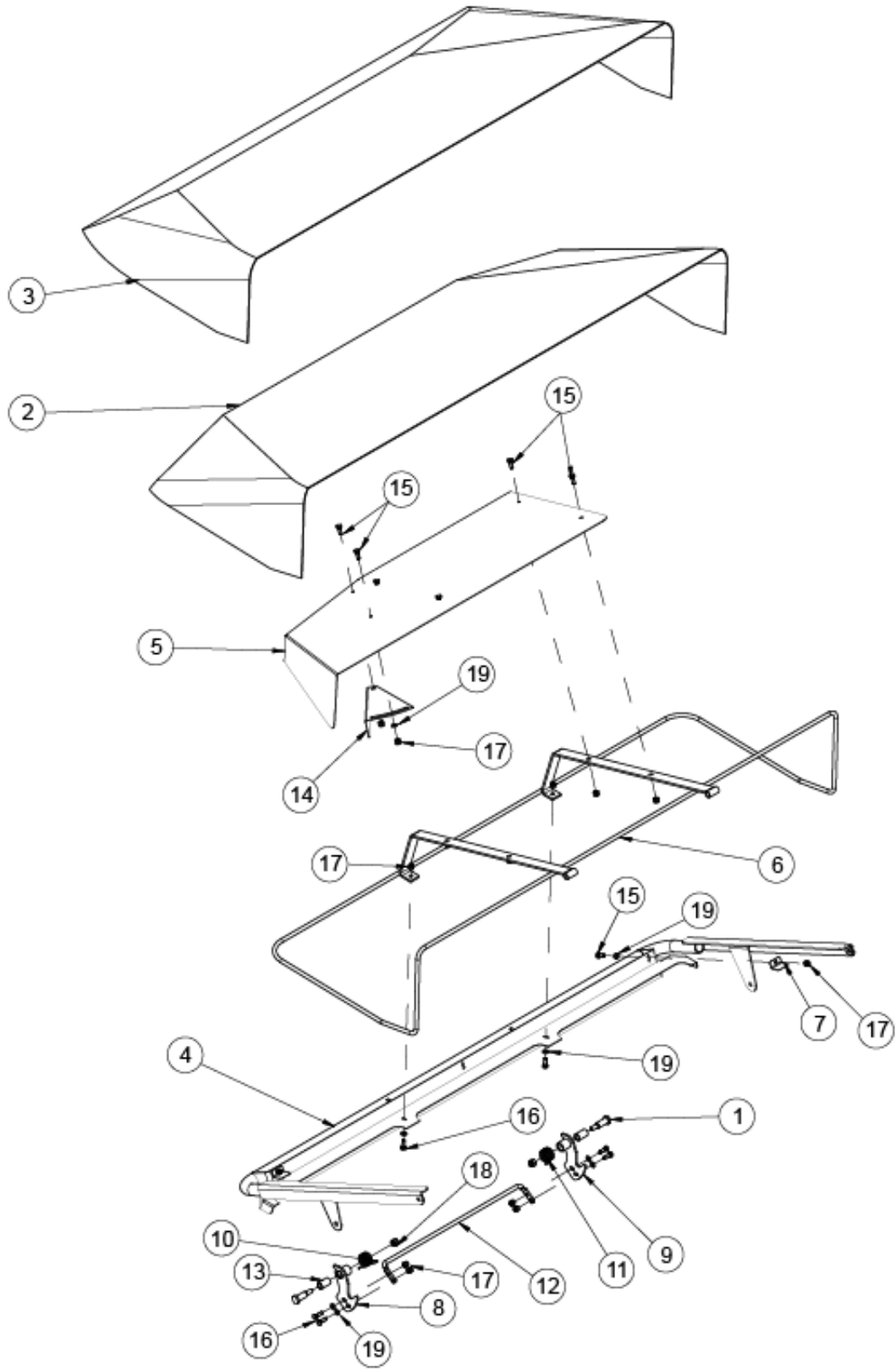

HOOD ASSEMBLY

ITEM	PART NO.	DESCRIPTION
1	2806055	AXIS PIN/SHOULDER BOLT
2	5101210	INNER DUST COVER
3	5101211	OUTER DUST COVER
4	5101221	HOOD FRAME ASM
5	5101223	PLATE, ADJUSTABLE DEFLECTOR
6	5101225	BAG FRAME W/LATCH
7	5210106	GRASS COVER
8	5210180	LEFT HAND HOOK
9	5210182	RIGHT HAND HOOK
10	5210183	TORSION SPRING, LH
11	5210184	TORSION SPRING, RH
12	5210187	HANDLE
13	5210188	BUSHING
14	5210212	PLATE
15	B5783-616	SCREW, HH TAP M6 X 16
16	B5783-618	HEX HD BOLT M6 X 18
17	B6182-6	NUT, NYLOC M6
18	B6182-8	NUT, NYLOC M8
19	B97.1-6	WASHER 6

GRASS CATCHER ASSEMBLY

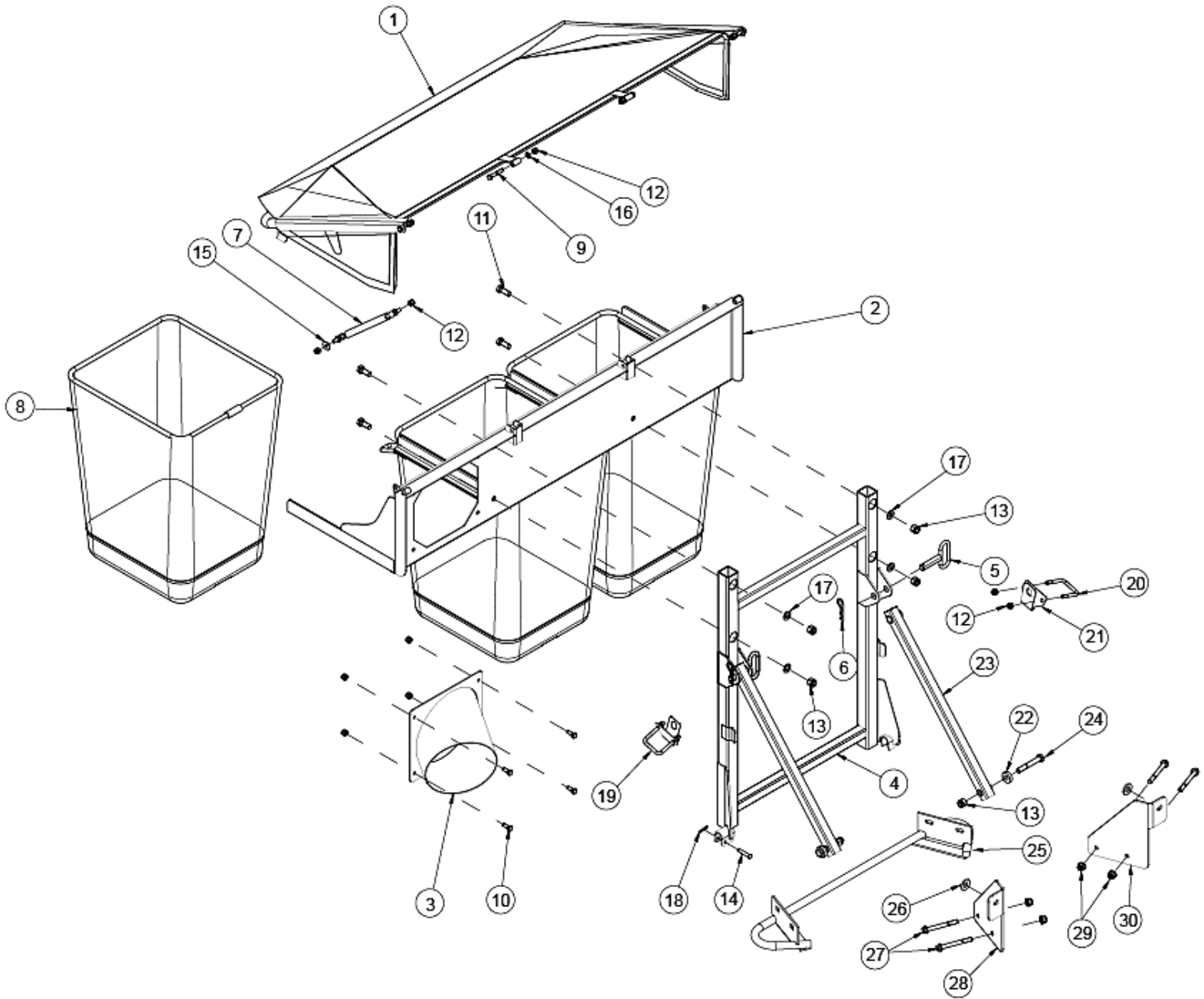

GRASS CATCHER ASSEMBLY

ITEM	PART NO.	DESCRIPTION
1	5101220	GRASS BAG PLATE
2	5101230	HOOD FRAME ASSEMBLY
3	5101235	HOOD INLET ADAPTOR
4	5101330	QUICK ATTACH BAGGERFRAME
5	5101345	PIN WELDMENT
6	5203203	HAIR PIN
7	5210107	DAMPER
8	5210170	GRASS BAG ASSEMBLY
9	B5782-845	BOLT M8 X 45
10	B5783-820	SCREW, HH TAP M8 X 20
11	B5783-1230	BOLT M12 X 30
12	B6182-8	NUT, NYLOC M8
13	B6182-12	N UT NYLOC M12
14	B882B-840	CLEVIS PIN 8 X 40
15	B96-8	WASHER 8
16	B97.1-8	WASHER 8
17	B97.1-12	WASHER 12
18	XSZ56-1-17	HAIR PIN
19	5101320	QUICK ATTACH BRACKET
20	5101327	U-BOLT M8 X 1.25
21	5101326	BRACKET, SUPPORT
22	5101311	SPACER
23	5101340	GC SUPPORT TUBE WLD
24	B5782-1280	SCREW, HH M12 X 80
25	5101320	GRASS CATCHER QUICK ATTACH BRACKET
26	105502	WASHER, SPRING DISC 1/2
27	B5787-1090	SCREW, HH FLANGE M1- X 90
28	633253-2	GUSSET, RH GC ROPS
29	B6183-10	NUT, NYLOC FLANGE M10
30	633252-2	GUSSET, LH GC ROPS

WEIGHT KIT ASSEMBLY

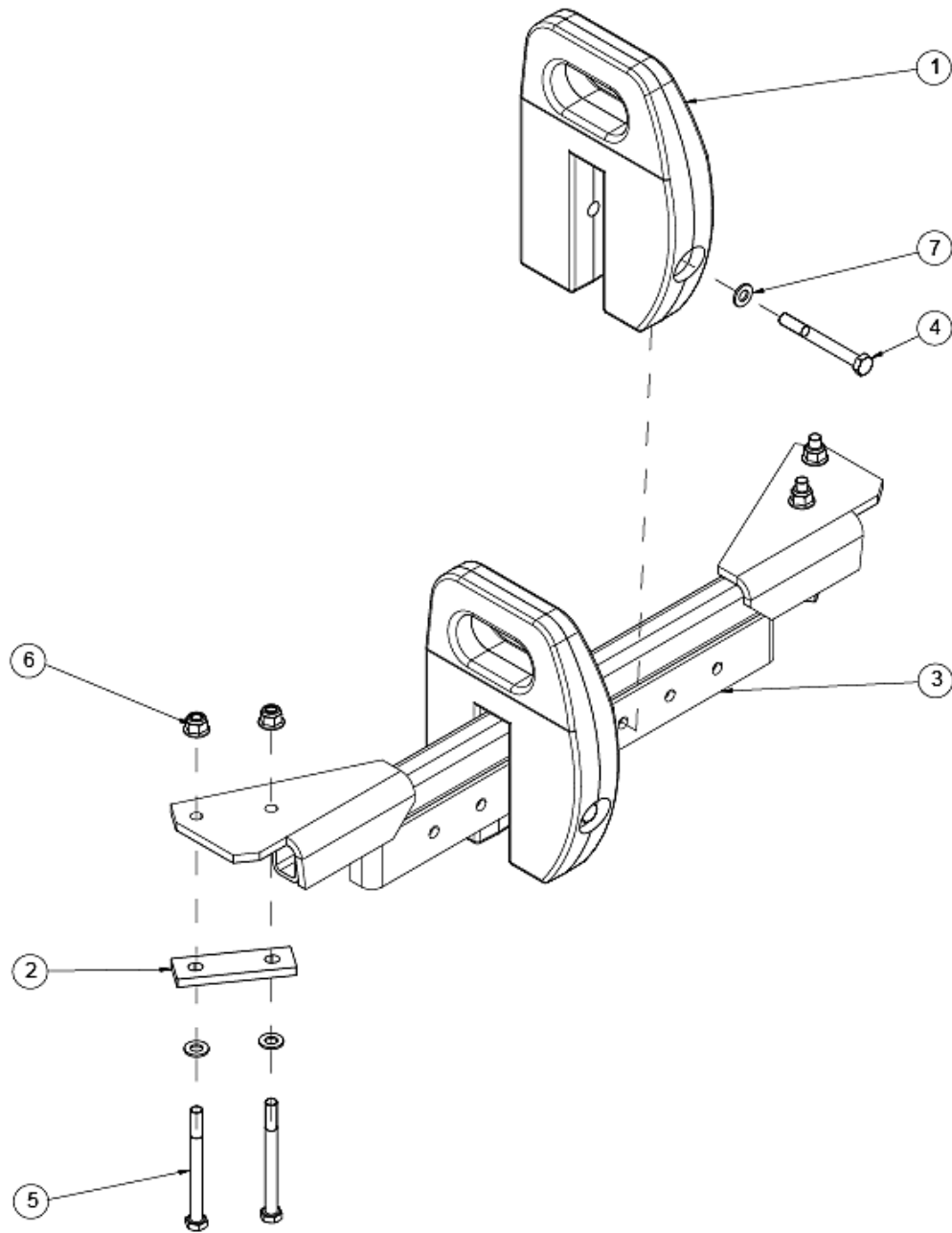

ITEM	PART NO.	DESCRIPTION
1	5101251	WEIGHTS (48" & 52" REQUIRE 2 PER; 60" REQUIRE 3 PER)
2	5101252	MOUNTING PLATE
3	5101355	WEIGHT BRACKET WLD
4	B5782-1090	BOLT M10 X 90
5	B5782-10110	BOLT M10 X 10
6	B6183-10	NUT, NYLOC FLANGE M10
7	B97.1-10	ASHER, FLAT M10

GRASSBAG ASSEMBLY

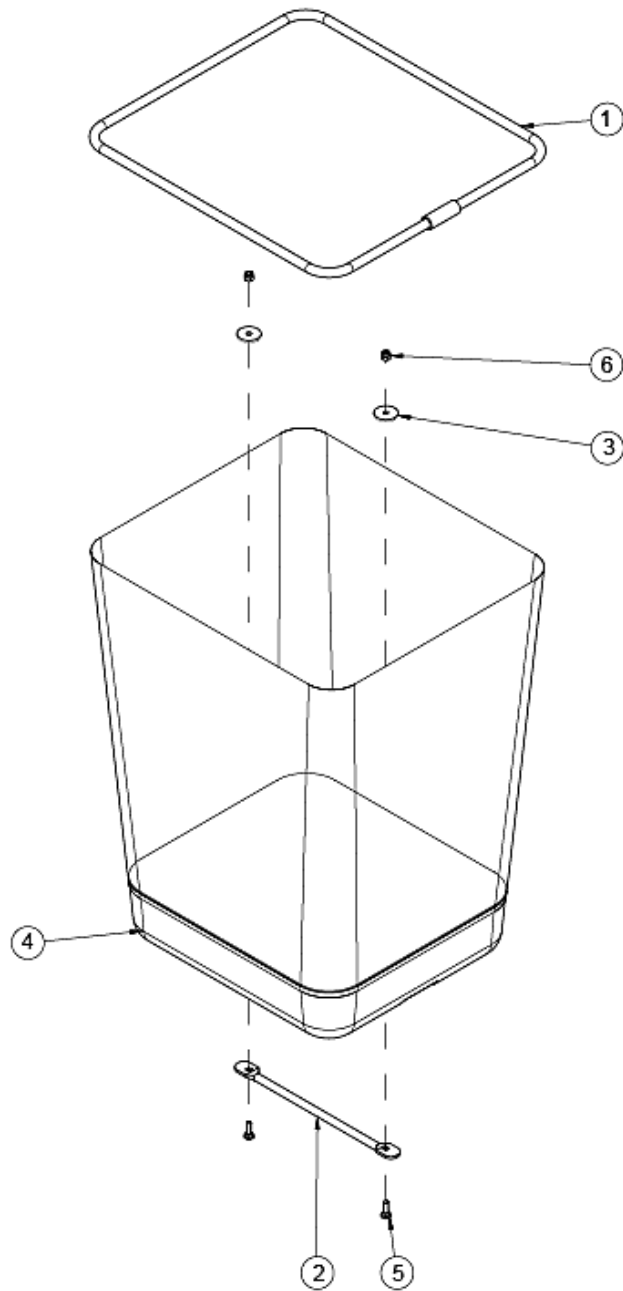

ITEM	PART NO.	DESCRIPTION
1	5210174	BAG FRAME
2	5210176	HANDLE – BAG
3	5210177	WASHER
4	5210178	GRASS BAG
5	B12-620	BOLT M6 X 20
6	B6182-6	NUT, NYLOC M6



