

WORLDLAWN®

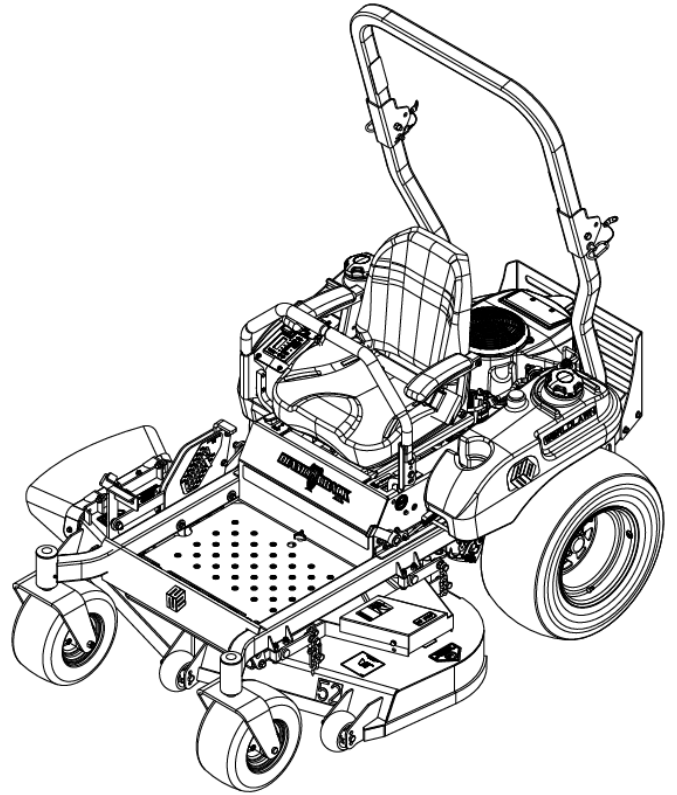

## PARTS MANUAL



WYDB48FR691V32  
WYDB48FR691V32CA  
WYDB52FR691V32  
WYDB52FR691V32CA



WYDB52FX691V34  
WYDB52FX691V34CA  
WYDB60FX691V34  
WYDB60FX691V34CA



WYDB52FS691V34  
WYDB52FS691V34CA  
WYDB52CT810V34  
WYDB52CT810V34CA  
WYDB60FS691V34  
WYDB60FS691V34CA



WYDB52FX691V34E  
WYDB60FX730V34E



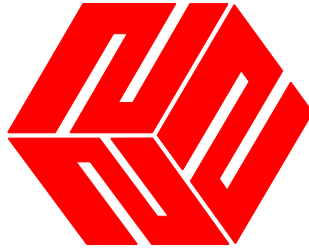

WORLDLAWN®

**WORLDLAWN POWER EQUIPMENT, INC.**

**WORLDLAWN.COM**

**401 COMMERCE STREET**

**BEATRICE, NE 68310**

**800-267-4255**

**FAX – 402-223-4103**



## Contents

48" CASTER ASSEMBLY.....	7
52" – 60" CASTER ASSEMBLY.....	8
FRAME ASSEMBLY .....	9
MOTION CONTROL ASSEMBLY .....	12
SEAT ASSEMBLY.....	14
48" REAR TIRE ASSEMBLY .....	15
52" – 60" REAR TIRE ASSEMBLY .....	16
DECK LIFT ASSEMBLY .....	17
48" DECK ASSEMBLY .....	19
52" DECK ASSEMBLY .....	21
60" DECK ASSEMBLY .....	23
DECK IDLER ASSEMBLY .....	26
DECK IDLER .....	28
BRAKE CONTROL GROUP .....	29
ENGINE ASSEMBLY FR691 .....	31
ENGINE ASSEMBLY FS691 .....	33
ENGINE ASSEMBLY CT810 .....	35
ENGINE ASSEMBLY FX691.....	37
ENGINE ASSEMBLY FX730.....	39
FUEL ASSEMBLY DIAMONDBACK .....	41
FUEL ASSEMBLY DIAMONDBACK – CA.....	43
FUEL ASSEMBLY DIAMONDBACK XL/MAXX .....	45
FUEL ASSEMBLY DIAMONDBACK XL/MAXX – CA.....	47
HYDRO ASSEMBLY .....	49
ROPS ASSEMBLY .....	51
DIAMONDBACK BATTERY GROUP .....	52
DIAMONDBACK XL BATTERY GROUP.....	54
DIAMONDBACK MAXX BATTERY GROUP.....	56
DIAMONDBACK XE BATTERY GROUP .....	58
DIAMONDBACK WIRING HARNESS .....	60
DIAMONDBACK XL WIRING HARNESS.....	61
DIAMONDBACK MAXX WIRING HARNESS .....	62
DIAMONDBACK XE WIRING HARNESS.....	63
DECAL GROUP.....	64

---

## AVAILABLE ACCESSORIES

### FITS MODELS:

WYDB48FR691V32  
WYDB48FR691V32CA

### MULCH KIT:

461025                      48" MULCH KIT

### GRASS CATCHER ASSEMBLY

5101305                      48" GRASS CATCHER W/WEIGHTS  
632078                      48" BLOWER  
632093                      48" COLLECTION TUBE

### FITS MODELS:

WYDB52FR691V32	WYDB52FS691V34	WYDB52FX691V34
WYDB52FR691V32	WYDB52FS691V34CA	WYDB52FX691V34CA
	WYDB52CT810V34	WYDB52FX691V34E
	WYDB52CT810V34CA	

### MULCH KIT:

451004                      52" MULCH KIT

### GRASS CATCHER ASSEMBLY:

5101305                      52" GRASS CATCHER W/WEIGHTS  
632074                      52" BLOWER  
542119                      52" COLLECTION TUBE

### FITS MODELS:

WYDB60FS691V34  
WYDB60FS691V34CA  
WYDB60FX691V34  
WYDB60FX691V34CA  
WYDB60FX730V34E

### MULCH KIT:

631027                      60" MULCH KIT

### GRASS CATCHER ASSEMBLY:

632086                      60" GRASS CATCHER W/WEIGHTS  
632081                      60" BLOWER  
542120                      60" COLLECTION TUBE

## 48" CASTER ASSEMBLY

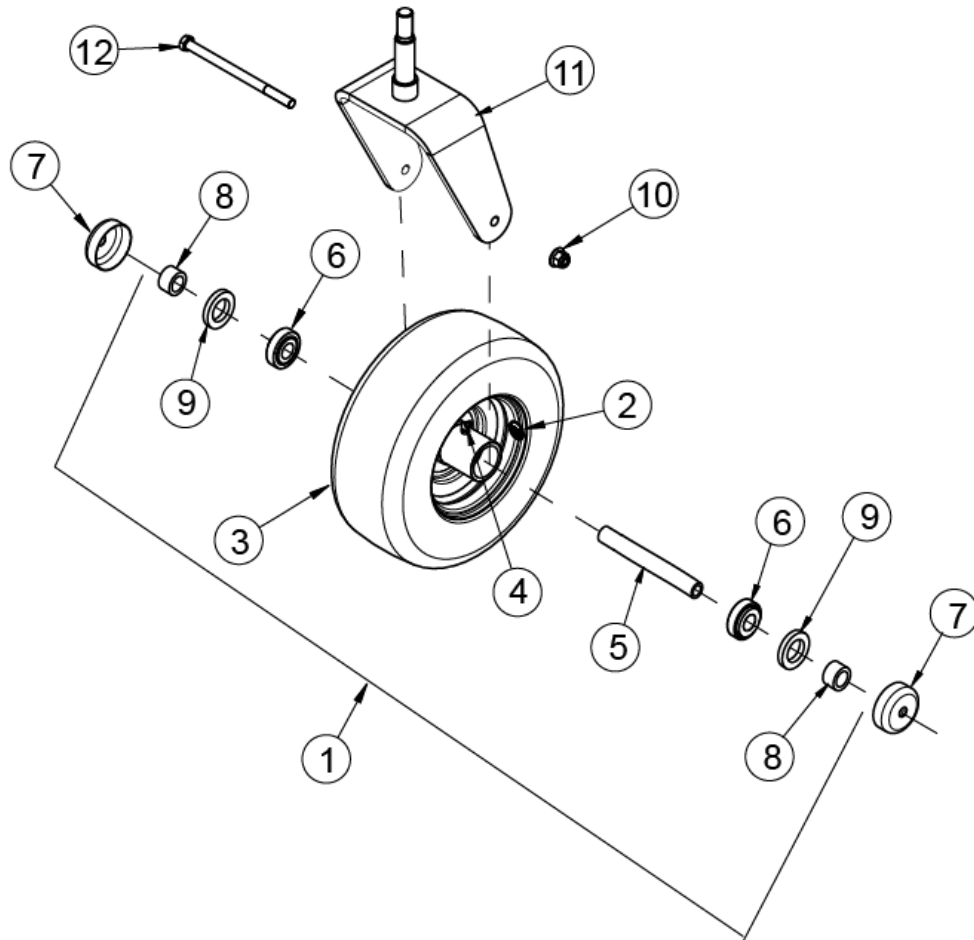

ITEM	PART NO.	DESCRIPTION
1	632068	ASM, BLK WHEEL COMPLETE 13 X 5.0-6 PNEUMATIC
2	453389	DECAL, FRONT TIRE PRESSURE
3	632069	TIRE AND RIM, BLK, 13 X 5.0-6 PNEUMATIC
	5202039	TIRE, 13 X 5.0-6 PNEUMATIC
4	111009	ZERK, 45° 1/4-28
5	5202038	TUBE, AXLE
6	5202037	BEARING, TAPERED ROLLER
7	5202026	CAP, DUST
8	5202035	BUSHING
9	5202036	SEAL, LIP
10	B6183-12	NUT, NYLOC FLANGE M12
11	5202150	CASTER WHEEL YOKE
12	5202029	SCREW, HH CAP M12 X 185

## 52" – 60" CASTER ASSEMBLY

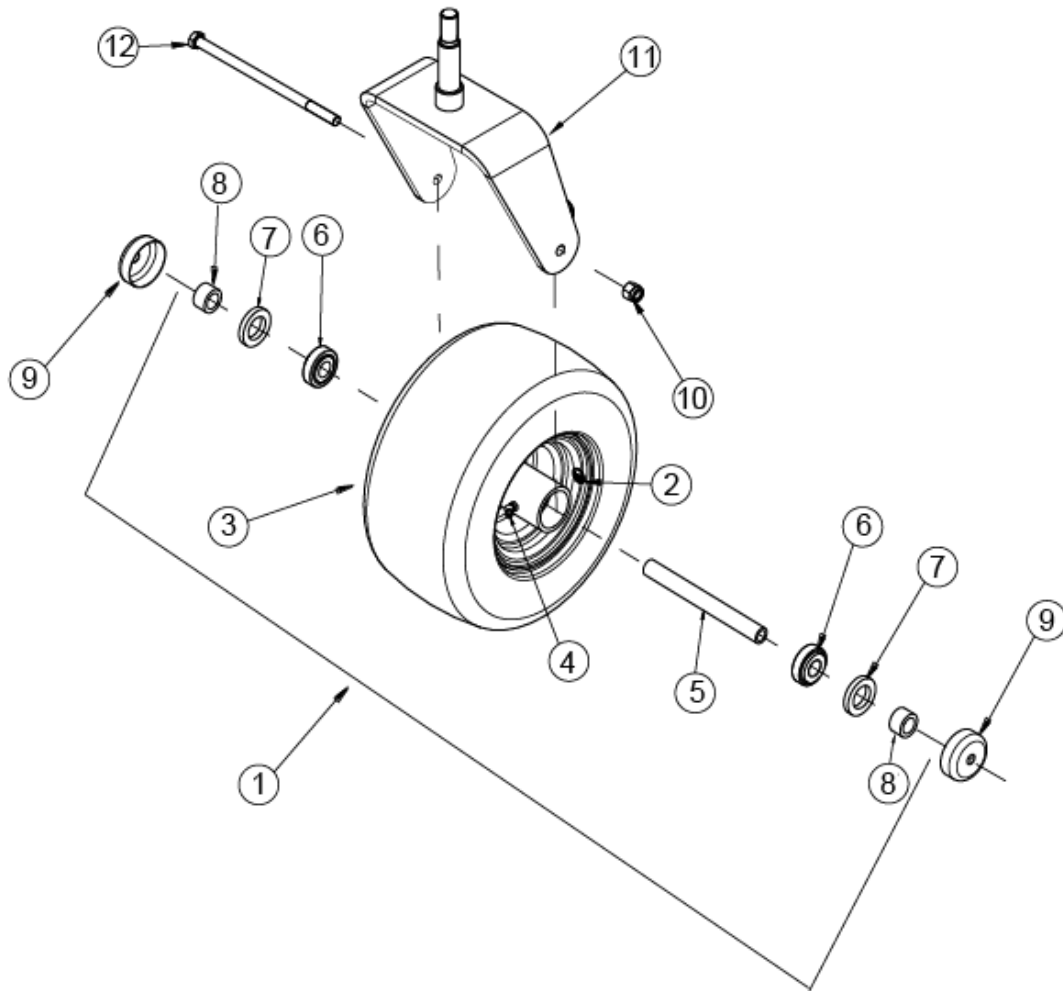

ITEM	PART NO.	DESCRIPTION
1	632041	ASM, BLK WHEEL COMPLETE W/BEARINGS
2	453389	DECAL, FRONT TIRE PRESSURE
3	632040	TIRE AND RIM, BLK, 13 X 6.5-6 PNEUMATIC
	542007	TIRE, 13 X 6.5-6 PNEUMATIC
4	111009	ZERK, 45° 1/4-28
5	543230	TUBE, AXLE
6	5202037	BEARING, TAPERED ROLLER
7	5202036	SEAL, LIP
8	5202035	BUSHING
9	5202026	CAP, DUST
10	B6182-12	NUT, NYLOC M12
11	542011-2	WLD, CASTER FORK 6.5, RED
12	543189	BOLT, M12 X 225 MM





## FRAME ASSEMBLY

ITEM	PART NO.	DESCRIPTION
1	B13871-B32528	SEAL (F) 32 X 52 X 8
2	B297-30205	BEARING 30205
3	B6182-20	NUT, NYLOC M20
4	5202009	DUST CAP
5	B1972-A40	WASHER, SPRING DISC A40
6	363201	FUEL TANK PAD
7	FOR REFERENCE ONLY	DECAL, SERIAL PLATE WL
8	543433	DECAL, FUEL VALVE
9	633120	RAMP, SEAT LATCH
10	543401	DECAL, OPERATOR SAFETY
11	B823-516	SCREW M5 X 16
12	523034	BRAKE SWITCH (NON-XL MODEL)
	2808005	BRAKE SWITCH (XL & MAXX MODELS)
13	633011-1	PLATE, FOOT, BLK
14	5208103	NUT RACK
15	633239	KNOB, 3-PRONGED W/STUD
16	633230	DECAL, DIAMONDBACK
	633222	DECAL, DIAMONDBACK XL
	633231	DECAL, DIAMONDBACK MAXX
	633276	DECAL, DIAMONDBACK XE
17	632055	ASM, SEAT CONSOLE W/DECALS
18	8324	DECAL, MOTION CONTROL
19	543391	DECAL, PARK BRAKE
20	543380	DECAL, BEATRICE
21	5203045	COVER
22	B5783-820	SCREW, HH TAP M8 X 20
23	633235-1	SHIELD, MUFFLER HEAT
24	B5787-820	SCREW, HH FLANGE M8 X 20
25	5002022	SPRING
26	453382	GROMMET, RUBBER 1-5/16" I.D.
27	543383	DECAL, WORL DLAWN COLOR
28	8318	DECAL, MUFFLER, TEMP
29	632057	ASM, REAR GUARD W/DECAL
30	B5787-1080	SCREW, FLANGE HEAD M10 X 80
31	B6183-10	NUT, NYLOC FLANGE M10
32	B6183-8	NUT, FLANGED NYLOC M8
33	B5787-825	SCREW, HH FLANGE M8 X 25
34	633234-1	STRAP, MUFFLER GUARD
35	5002030	RUBBER BUSHING
36	543396	DECAL, HYDRO RESERVOIR
37	632036	ASM, CLUTCH STOP
38	B801-8110	BOLT, CARRIAGE SN M8 X 110
39	633118	SPACER, TUBE
40	5203408	WASHER

---



---

### FRAME ASSEMBLY

ITEM	PART NO.	DESCRIPTION
41	5203411	CLUTCH STOP STRAP
42	5203409	SPACER/BUSHING
43	B6182-8	NUT, NYLOC M8
44	B97.1-8	WASHER 8
45	B5783-835	BOLT, M8 X 35
46	5203410	RUBBER RING 17
47	632024	ASM, BASIC PS FRAME
48	B5787-1240	SCREW, HH FLANGED M12 X 40
49	453288	BUSHING
50	B6183-12	NUT, NYLOC FLANGE M12
51	633010-2	FRONT STRUT PLATE – RED
52	B1152-6	GREASE FITTING M6
53	633236	DECAL, WORLDLAWN 21” W/GRN
54	633258-1	WEIGHT, REAR – STANDARD ON 60”
55	B5787-1030	SCREW, HH FLANGE M10x30 – STANDARD ON 60”

## MOTION CONTROL ASSEMBLY

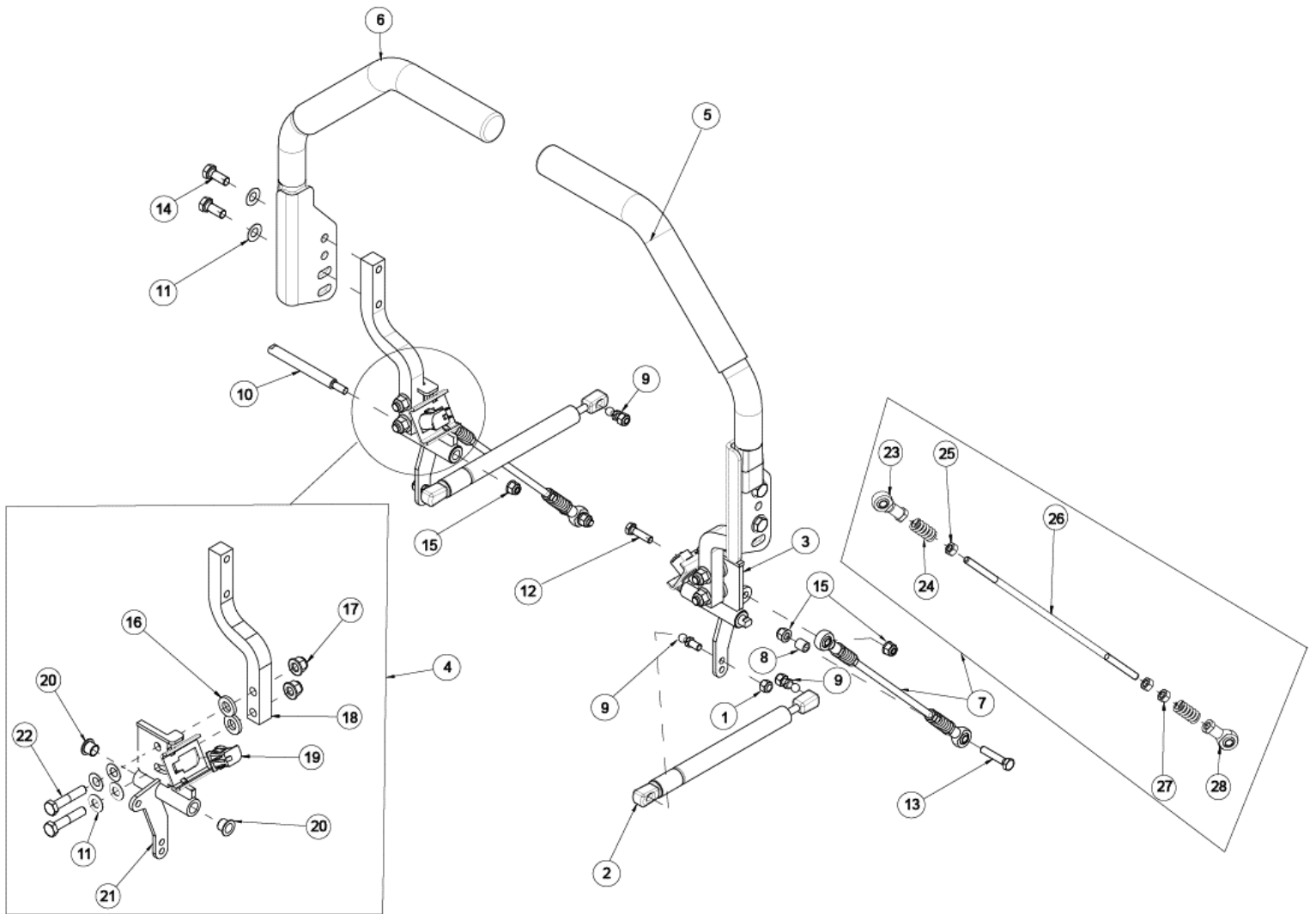

## MOTION CONTROL ASSEMBLY

ITEM	PART NO	DESCRIPTION
1	104256	5/16-18 HEX NYLOC NUT
2	583415	DAMPENER/CONTROL
3	632009	ASM, MOTION CONTROL LH
4	632010	ASM, MOTION CONTROL RH
5	632028	ASM, DRIVE LEVER LH W/GRIP
6	632029	ASM, DRIVE LEVER RH W/GRIP
	543156	GRIP, MOTION CONTROL LEVER
7	632030	ASM, HYDRO LINKAGE
8	633042	SPACER
9	823221	10MM BALL STUD
10	5002111	OPERATING SHAFT
11	B1972-A22.5-2	WASHER, SPRING DISC A22.5 OD
12	B5783-830	SCREW, HH TAP M8x30
13	B5783-840	SCREW, HH TAP M8 X 40
14	B5783-1025	SCREW, HH TAP M10x25
15	B6183-8	NUT, FLANGED NYLOC M8
16	543152	WASHER, PLASTIC
17	B6183-10	NUT, NYLOC FLANGE M10
18	633025	MOTION CONTROL ARM
19	353048	SEAT SWITCH
20	543154	BUSHING, MOTION CONTROL
21	632011	WLD, MOTION CONTROL, LH
22	B5782-1050	BOLT 10X50
23	5205017	ROD END, SPHERICAL M8 LH SILBJK8S
24	5205003	SPRING, COMPRESSION
25	B6171-8L	NUT M8X1 (LH)
26	633088	ROD
27	B6171-8	NUT M8
28	5205016	ROD END, SPHERICAL M8 RH SIBJK8S

## SEAT ASSEMBLY

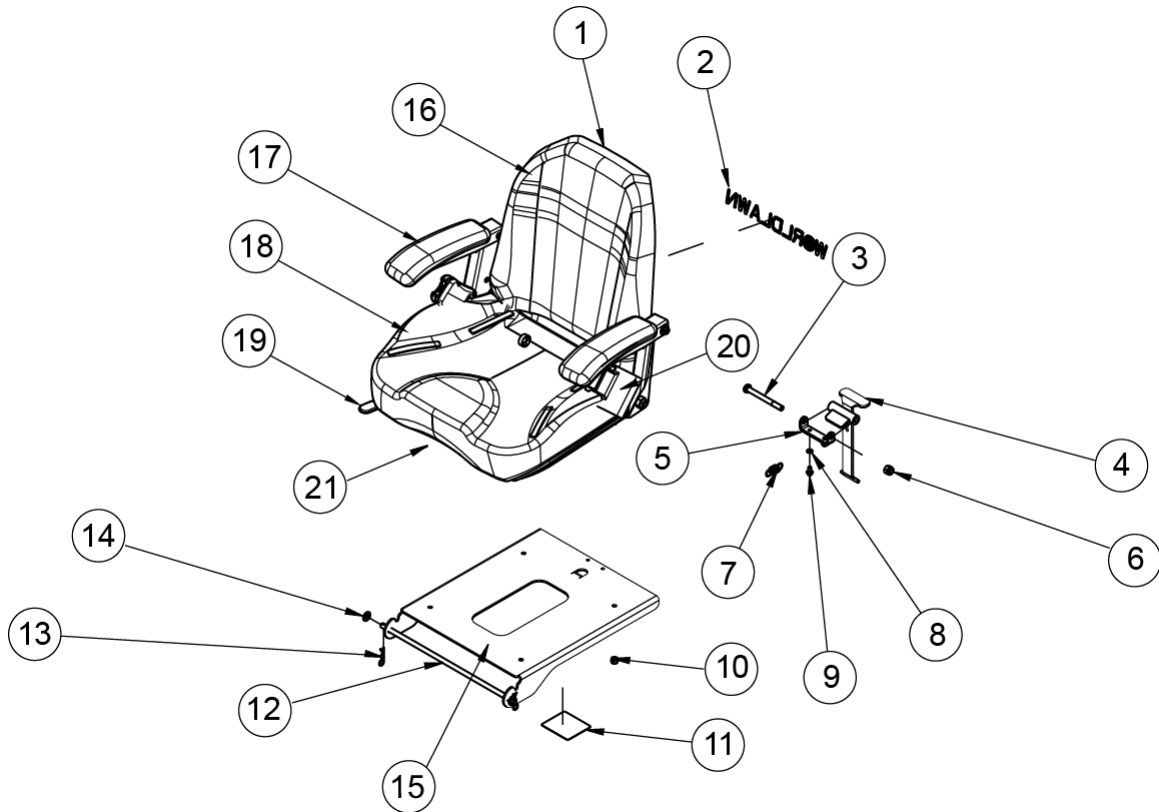

ITEM	PART NO.	DESCRIPTION
1	543373	SEAT
2	463444	DECAL, WORLDLAWN LG W/GRN
3	B5782-10100	BOLT M10X100
4	632018	WLD, SEAT LATCH
5	633050	STRAP, BRAKE LEVER
6	B6182-10	NUT, NYLOC M10
7	S262008	RETURN SPRING
8	B97.1-6	WASHER 6
9	B5787-612	SCREW, FLANGED HH M6 X 12
10	104256	5/16-18 HEX NYLOC NUT
11	543397	DECAL, BATTERY WARNING
12	633111	ROD, SEAT
13	363165	HAIRPIN COTTER
14	B97.1-10	WASHER, FLAT M10
15	632056	ASM, SEAT PAN W/DECAL
16	543440	BACK, SEAT
17	593097	ARM REST PAD – MOLDED
18	543439	CUSHION, SEAT
19	543438	KIT, SEAT TRACK 4"
20	543004	KIT, SEAT BELT, RETRACTABLE
21	353048	SEAT SWITCH

## 48" REAR TIRE ASSEMBLY

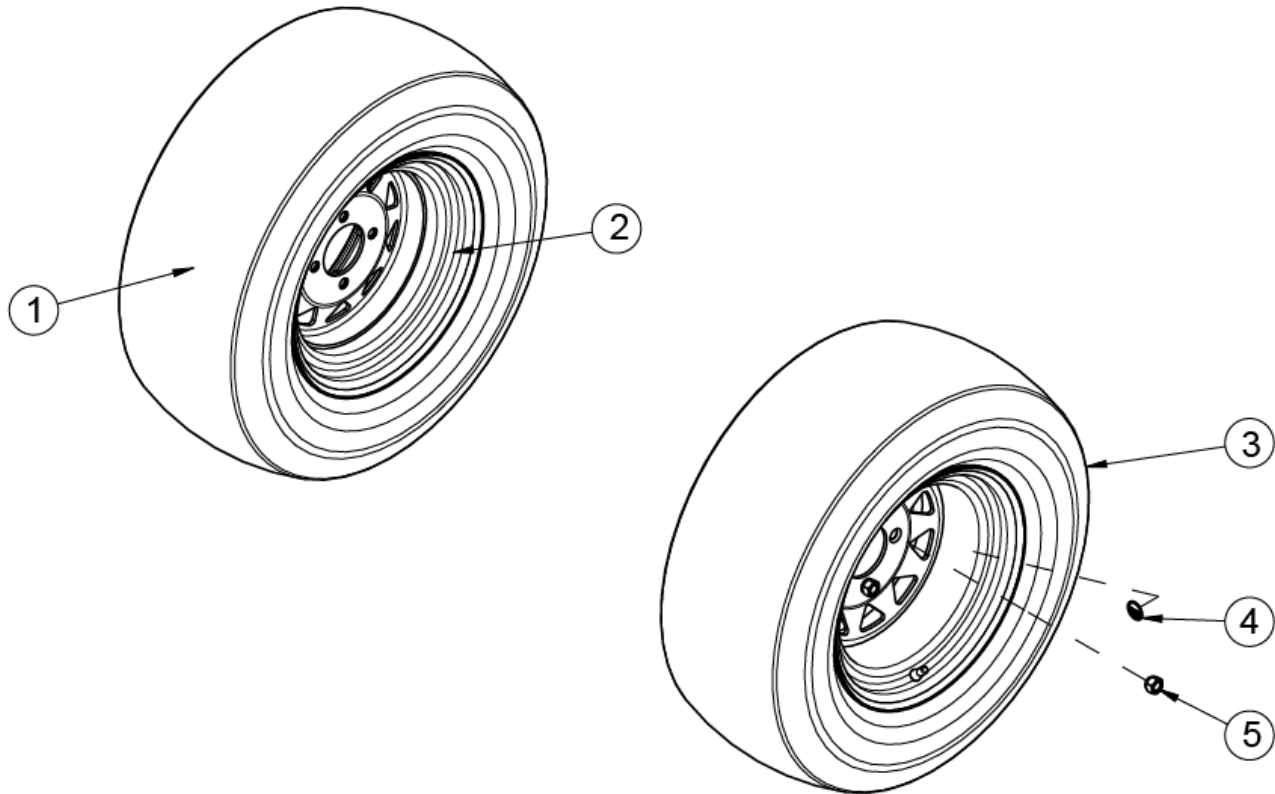

ITEM	PART NO.	DESCRIPTION
1	542073	TIRE, 23 X 9.5-12
2	633148	WHEEL, BLK 12 X 7
3	632067	ASM, BLK WHEEL 23 X 9.5-12
4	453390	DECAL, REAR TIRE PRESSURE
5	103023	1/2-20 X 60 T LUG NUT

## 52" – 60" REAR TIRE ASSEMBLY

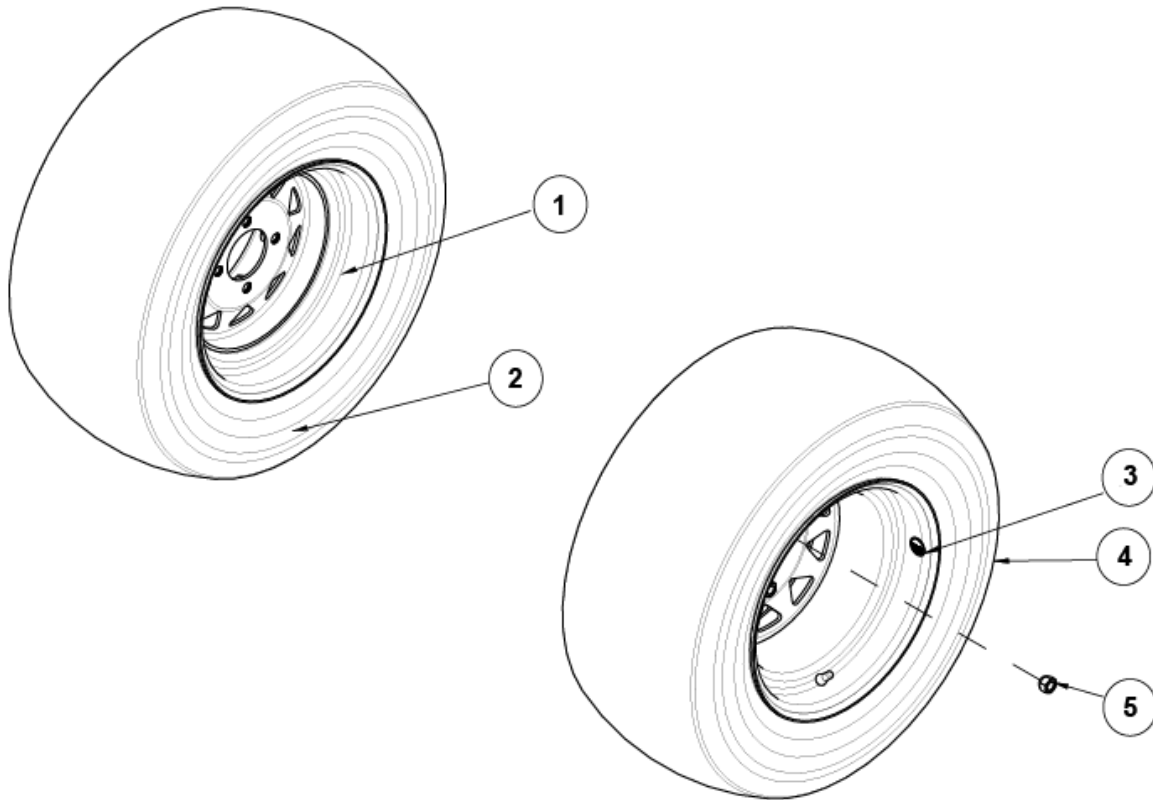

ITEM	PART NO.	DESCRIPTION
1	633226	WHEEL, BLK 12 X 8.5
2	5200011	CARLISLE TURF MATE 23X10.5-12
3	453390	DECAL, REAR TIRE PRESSURE
4	632039	ASM, BLK WHEEL 23 X 10.5-12
5	103023	1/2-20 X 60 T LUG NUT



## DECK LIFT ASSEMBLY

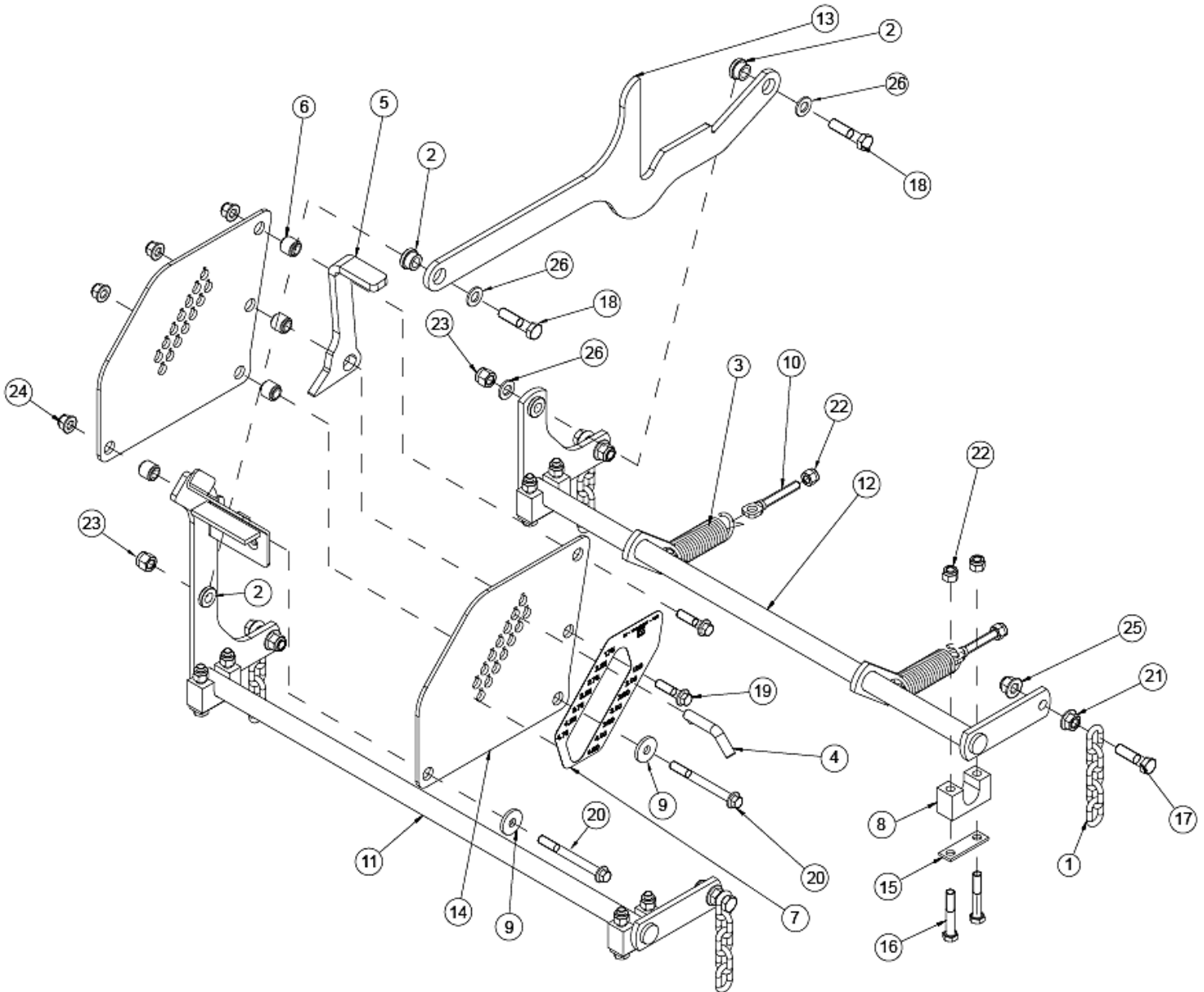

## DECK LIFT ASSEMBLY

ITEM	PART NO	DESCRIPTION
1	423359	FRONT CHAIN (5 LINKS)
2	453288	BUSHING
3	523327	FLOATING IDLER SPRING
4	543207	PIN, HOC
5	633031	LATCH, TRANSPORT
6	633032	SPACER, HOC
7	633106	DECAL, DECK HEIGHT
8	633119	BLOCK, 25MM PIVOT
9	5201083	SPACER
10	2802083B	CONNECTING ROD
11	632004-1	WLD, FT CROSS SHAFT – BLK
12	632005-1	WLD, REAR CROSS SHAFT – BLK
13	633027-1	DECK LIFT LINK – BLACK
14	633028-1	PLATE, HOC – BLACK
15	633220-1	PLATE, 25MM PIVOT BLOCK
16	B5782-1060	BOLT 10X60
17	B5782-1245	SCREW, HH M12 X 45
18	B5782-1250	SCREW, HH CAP M12 X 50
19	B5787-1040	SCREW, HH FLANGE M10X40
20	B5787-10100	SCREW, HH FLANGED M10 X 100
21	B6177-12	NUT, FLANGED M12
22	B6182-10	NUT, NYLOC M10
23	B6182-12	NUT, NYLOC M12
24	B6183-10	NUT, NYLOC FLANGE M10
25	B6183-12	NUT, NYLOC FLANGE M12
26	B97.1-12	WASHER 12

## 48" DECK ASSEMBLY

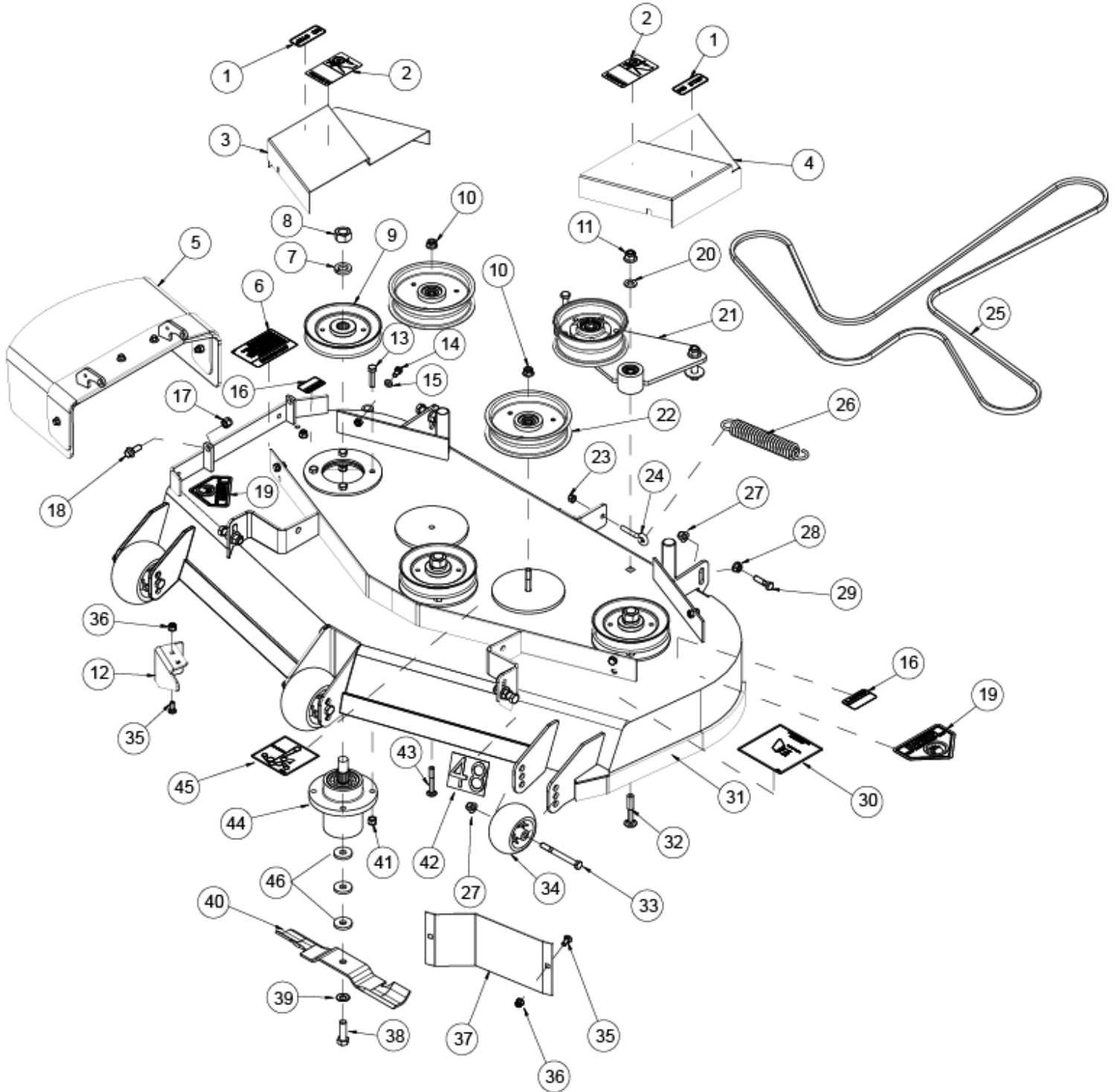

## 48" DECK ASSEMBLY

ITEM	PART NO.	DESCRIPTION
1	8304	DECAL, NO STEP
2	8008	DECAL, CAUTION, GUARDING LG
3	632089	SHIELD, RH DB 48 BELT W/DECALS
4	632088	SHIELD, LH DB 48 BELT W/DECALS
5	4801050	ASM, DISCHARGE CHUTE
6	8307	DECAL, DISCHARGE WARNING
7	105010	3/4" LOCKWASHER
8	104511	3/4-16 UNF REG HEX NUT
9	632061	PULLEY, 48" DECK
10	B6187-10	FLANGED TOPLOCK M10
11	B6183-12	NUT, NYLOC FLANGE M12
12	543212-2	BAFFLE, DOGLEG 48", RED
13	100294	3/8-16 X 1-1/2 HHCS
14	B5783-816	SCREW, HH TAP M8 X 16
15	B97.1-8	WASHER 8
16	8303	DECAL, CAUTION, GUARDING SM
17	B6182-10	NUT, NYLOC M10
18	B5787-1025	SCREW, HH FLANGE M10 X 25
19	363023	DANGER DECAL, HANDS AND FEET
20	B97.1-12	WASHER 12
21	632034	ASM, DECK IDLER – DETAIL ON PG 26
22	542147	ASM, 150MM FLAT IDLER W/SPACER – DETAIL ON PG 28
23	104256	5/16-18 HEX NYLOC NUT
24	363080	EYEBOLT – RIGHT
25	633147	BELT, 48 DECK
26	523109	LIFT TENSION SPRING
27	B6183-12	NUT, NYLOC FLANGE M12
28	B6177-12	NUT, FLANGED M12
29	B5782-1245	SCREW, HH M12 X 45
30	543392	DECAL, ANTI-SCALP ROLLER
31	632087	ASM, 48 DB DECK W/DECALS
32	B801-1265	BOLT, CARRIAGE M12 X 65
33	B5782-12120	SCREW, HH M12 X 120
34	543225	ROLLER, ANTI SCALP
35	B801-820	BOLT, CARRIAGE SN M8 X 20
36	B6183-8	NUT, FLANGED NYLOC M8
37	543216-2	BAFFLE, BIRDWING 48, RED
38	100347	5/8-11 X 2 HHCS
39	583108	5/8 SPRING DISC WASHER
40	483103	BLADE, 48"
41	104257	3/8-16 HEX NYLOC NUT
42	8328	DECAL, 48
43	B801-1060	BOLT, CARRIAGE M10 X 60
44	583106	BLADE SPINDLE ASM – DETAIL ON PG 25
45	633228	DECAL, BELT ROUTING
46	363382	BLADE SPACER

## 52" DECK ASSEMBLY

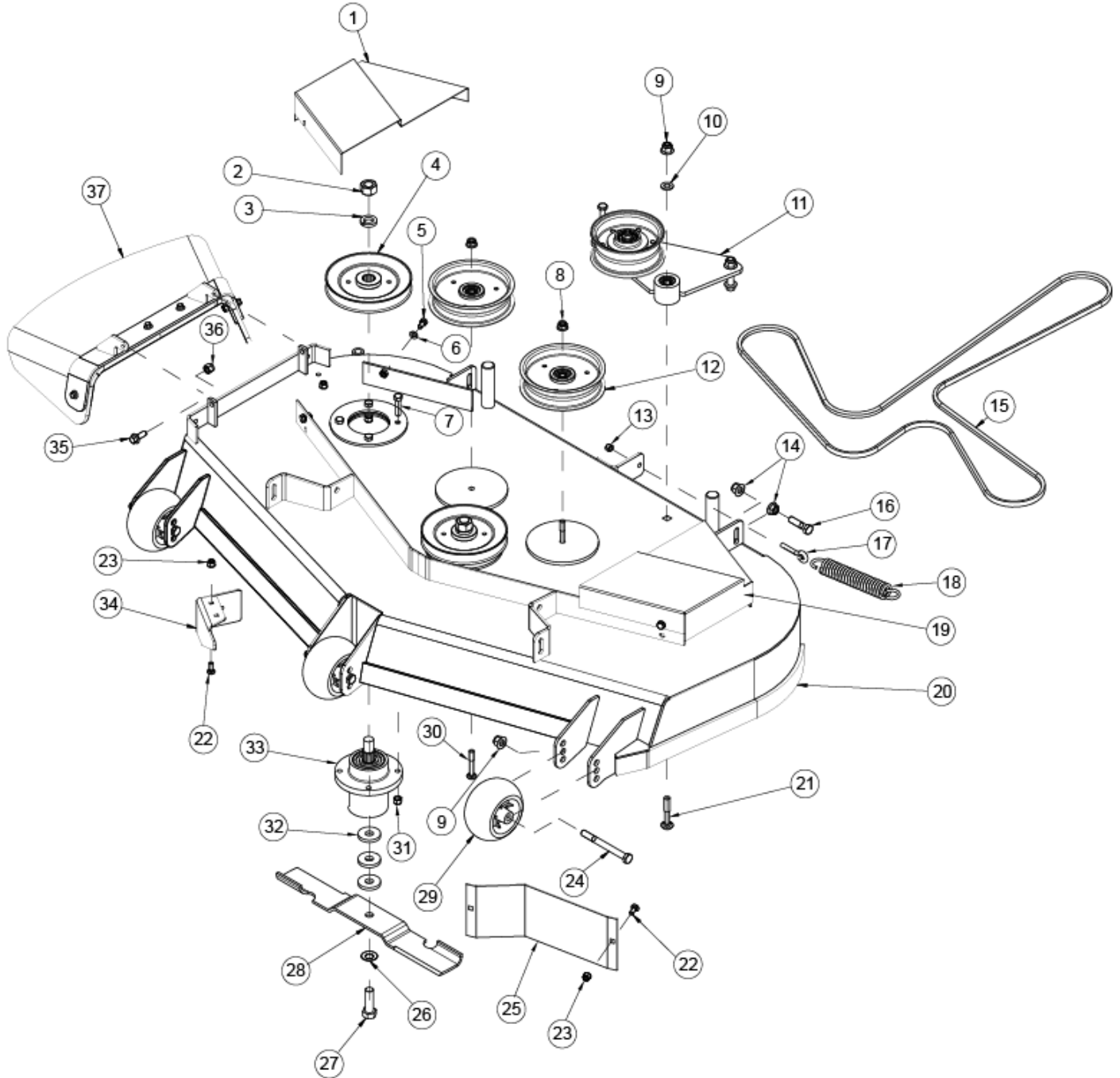

## 52" DECK ASSEMBLY

ITEM	PART NO.	DESCRIPTION
1	632047	SHIELD, RH DB 52 BELT, W/DECALS
2	104511	3/4-16 UNF REG HEX NUT
3	105010	3/4 LOCKWASHER
4	452073	PULLEY, DECK
5	B5783-816	SCREW, HH TAP M8x16
6	B97.1-8	WASHER 8
7	100294	3/8-16 X 1-1/2 HHCS
8	B6187-10	FLANGED TOPLOCK M10
9	B6183-12	NUT, NYLOC FLANGE M12
10	B97.1-12	WASHER 12
11	632034	ASM, DECK IDLER - DETAIL ON PG 26
12	542147	ASM, 150MM FLAT IDLER W/SPACER- DETAIL ON PG 28
13	104256	5/16-18 HEX NYLOC NUT
14	B6177-12	NUT, FLANGED M12
15	633068	BELT, DECK
16	B5782-1245	SCREW, HH M12 X 45
17	363080	EYEBOLT-RIGHT
18	5207015	IDLER PULLEY SPRING
19	632046	SHIELD, LH DB 52 BELT, W/DECALS
20	632050	ASM, 52 DB DECK W/DECALS
21	B801-1265	BOLT, CARRIAGE M12 X 65
22	B801-820	BOLT, CARRIAGE SN M8X20
23	B6183-8	NUT, FLANGED NYLOC M8
24	B5782-12120	SCREW, HH M12 X 120
25	543046	BAFFLE, BIRDWING LH
26	583108	5/8 SPRING DISC WASHER
27	100347	5/8-11 X 2 HHCS
28	823004	18" HI LIFT BLADE
29	543225	ROLLER, ANTI SCALP
30	B801-1060	BOLT, CARRIAGE M10 X 60
31	104257	3/8-16 HEX NYLOC NUT
32	363382	BLADE SPACER
33	583106	BLADE SPINDLE ASSY - DETAIL ON PG 25
34	543213-2	BAFFLE, DOGLEG 52, RED
35	B5787-1025	SCREW, HH FLANGE M10x25
36	B6182-10	NUT, NYLOC M10
37	6001050A	ASM, DISCHARGE CHUTE 52/60

## 60" DECK ASSEMBLY

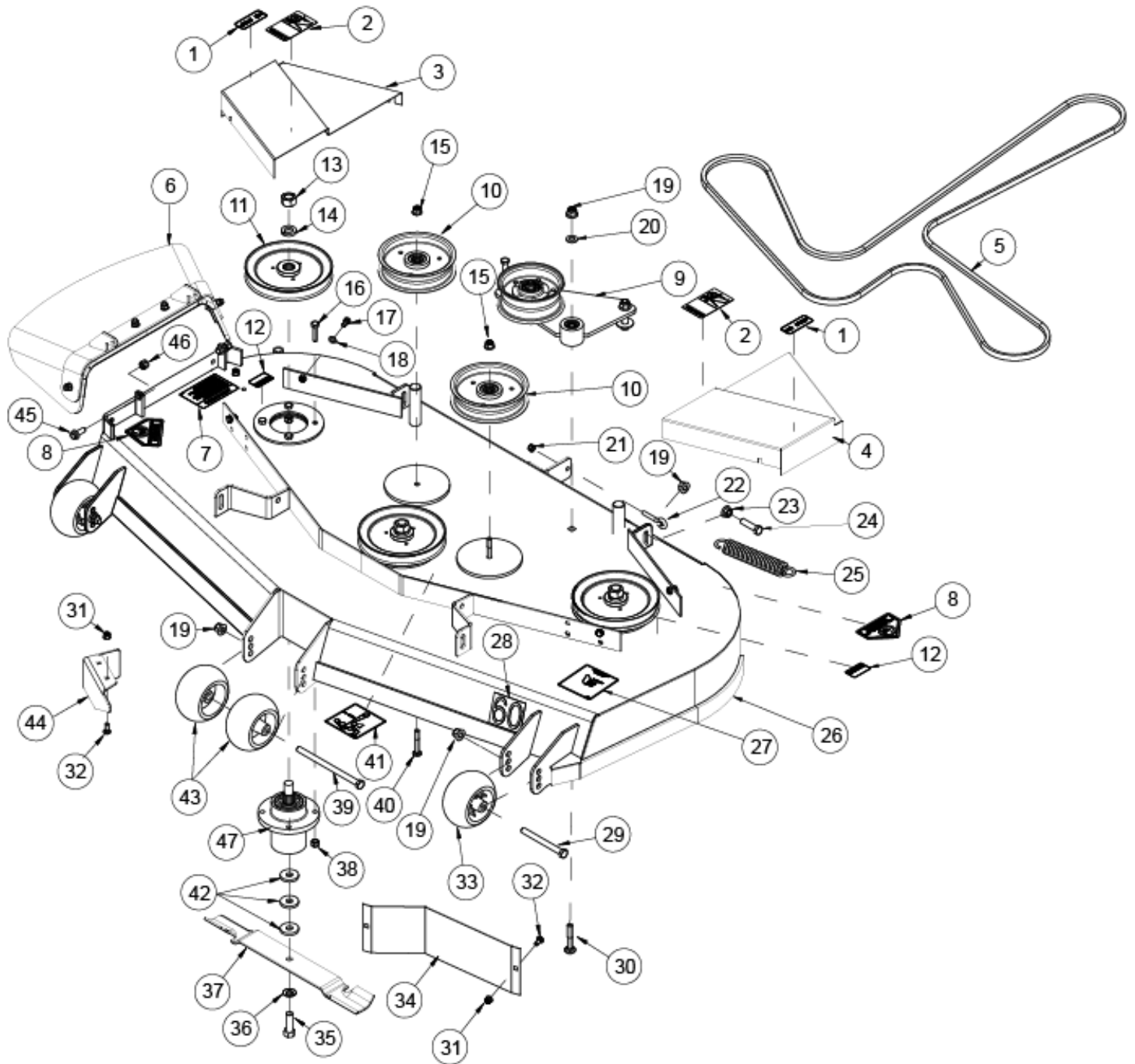

## 60" DECK ASSEMBLY

ITEM	PART NO.	DESCRIPTION
1	8304	DECAL, NO STEP
2	8008	DECAL, CAUTION, GUARDING LG
3	632092	SHIELD, RH DB 60 BELT W/DECALS
4	632091	SHIELD, LH DB 60 BELT W/DECALS
5	633338	BELT, 60 DECK
6	6001050A	ASM, DISCHARGE CHUTE 52/60
7	8307	DECAL, DISCHARGE WARNING
8	363045	IDLER ARM BRACKET
9	632034	ASM, DECK IDLER – DETAIL ON PG 26
10	542147	ASM, 150MM FLAT IDLER W/SPACER – DETAIL ON PG 28
11	632044	PULLEY, 60 DB DECK
12	8303	DECAL, CAUTION, GUARDING SM
13	104511	3/4-16 UNF REG HEX NUT
14	105010	3/4 LOCKWASHER
15	B6183-10	NUT, NYLOC FLANGE M10
16	100294	3/8-16 X 1-1/2 HHCS
17	B5783-816	SCREW, HH TAP M8 X 16
18	B97.1-8	WASHER 8
19	B6183-12	NUT, NYLOC FLANGE M12
20	B97.1-12	WASHER 12
21	104256	5/16-18 HEX NYLOC NUT
22	363080	EYEBOLT – RIGHT
23	B6177-12	NUT, FLANGED M12
24	B5782-1245	SCREW, HH M12 X 45
25	523109	LIFT TENSION SPRING
26	632090	ASM, 60 DB DECK W/DECALS
27	543392	DECAL, ANTI-SCALP ROLLER
28	8327	DECAL, "60"
29	B5782-12120	SCREW, HH M12 X 120
30	B801-1265	BOLT, CARRIAGE M12 X 65
31	B6183-8	NUT, FLANGED NYLOC M8
32	B801-820	BOLT, CARRIAGE SN M8 X 20
33	543225	ROLLER, ANTI SCALP
34	543217-2	BAFFLE, BIRDWING 60, RED
35	100347	5/8-11 X 2 HHCS
36	583108	5/8 SPRING DISC WASHER
37	633335	BLADE, 20.5" HI-LIFT
38	104257	3/8-16 HEX NYLOC NUT
39	5202029	SCREW, HH CAP M12 X 185
40	B801-1060	BOLT, CARRIAGE M10 X 60
41	633228	DECAL, BELT ROUTING
42	363382	BLADE SPACER
43	423023	ROLLER, ANTI SCALP
44	543214-2	BAFFLE, DOGLEG 60, RED
45	B5787-1025	SCREW, HH FLANGE M10 X 25
46	B6182-10	NUT, NYLOC M10
47	583106	BLADE SPINDLE ASM – DETAIL ON PG 25



## SPINDLE HOUSING ASSEMBLY

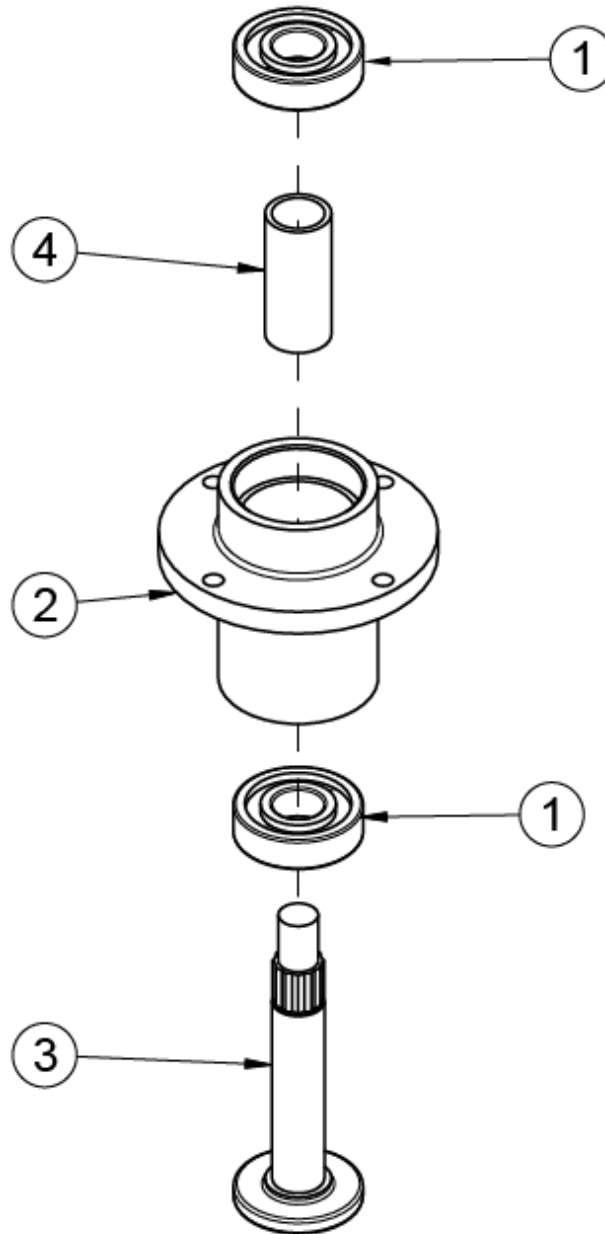

ITEM	PART NO.	DESCRIPTION
1	363350	BEARING – BLADE SPINDLE
2	583111	SPINDLE HOUSING
3	583112	SPINDLE SHAFT
4	583113	BEARING SPACER TUBE

## DECK IDLER ASSEMBLY

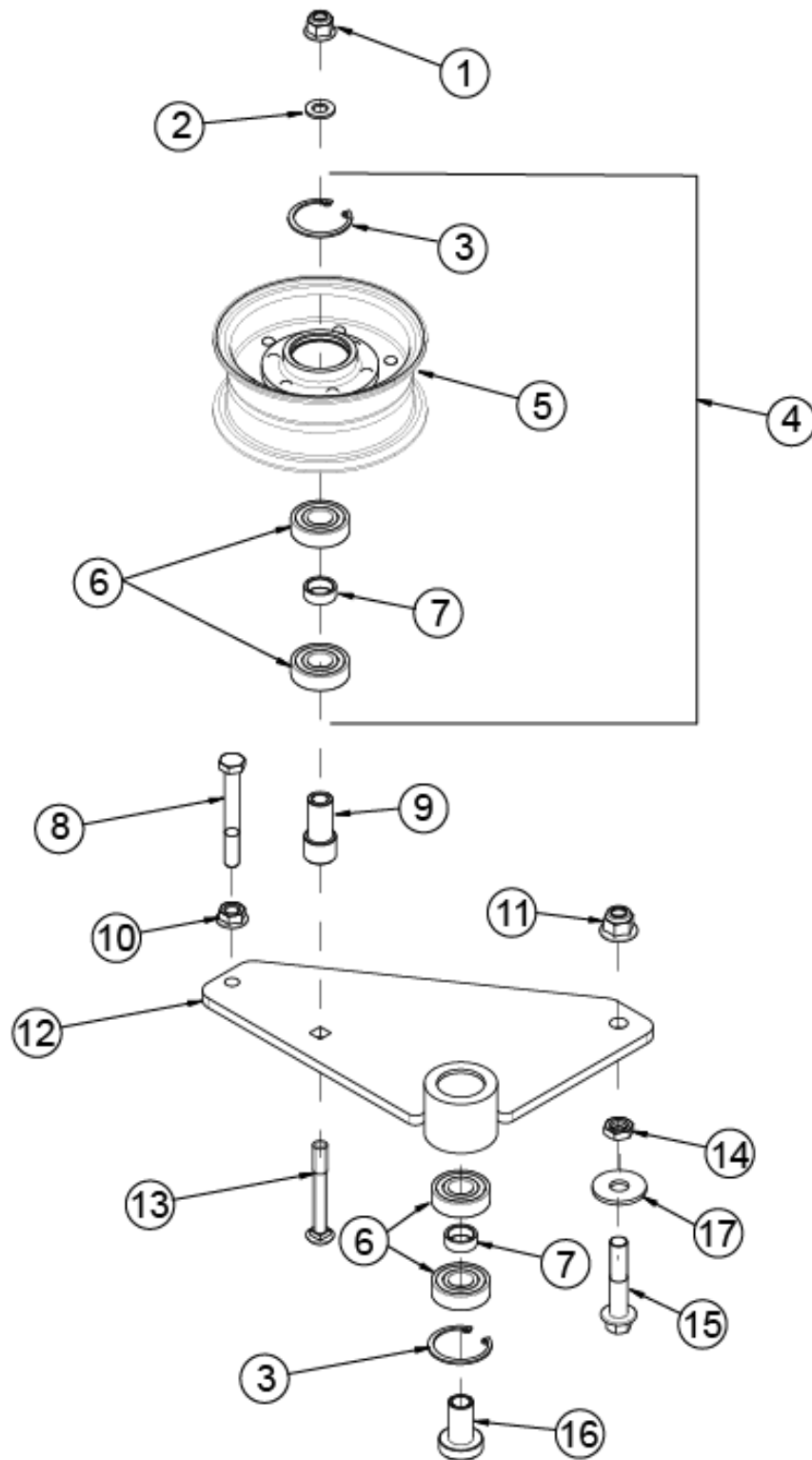

---

## DECK IDLER ASSEMBLY

ITEM	PART NO.	DESCRIPTION
1	B6183-10	NUT, NYLOC FLANGE M10
2	B97.1-10	WASHER, FLAT M10
3	B893.1-40	SNAP RING 40
4	462072	ASM, IDLER PULLEY
5	5201064	IDLER PULLEY
6	B276-6203RS	BEARING 6203-2RS
7	5201077	BUSHING
8	B5782-1080	BOLT M10 X 80
9	463220	SPACER, IDLER PULLEY
10	B6177-10	NUT, FLANGED M10
11	B6183-12	NUT, NYLOC FLANGE M12
12	632033	DECK IDLER ARM
13	B801-1075	BOLT, CARRIAGE M10 X 75
14	B6172.1-12	NUT, JAM M12
15	B5787-1260	SCREW, HH FLANGE M12 X 60
16	633015	STEPPED SPACER
17	B96-12	WASHER, FLAT LARGE M12

## DECK IDLER

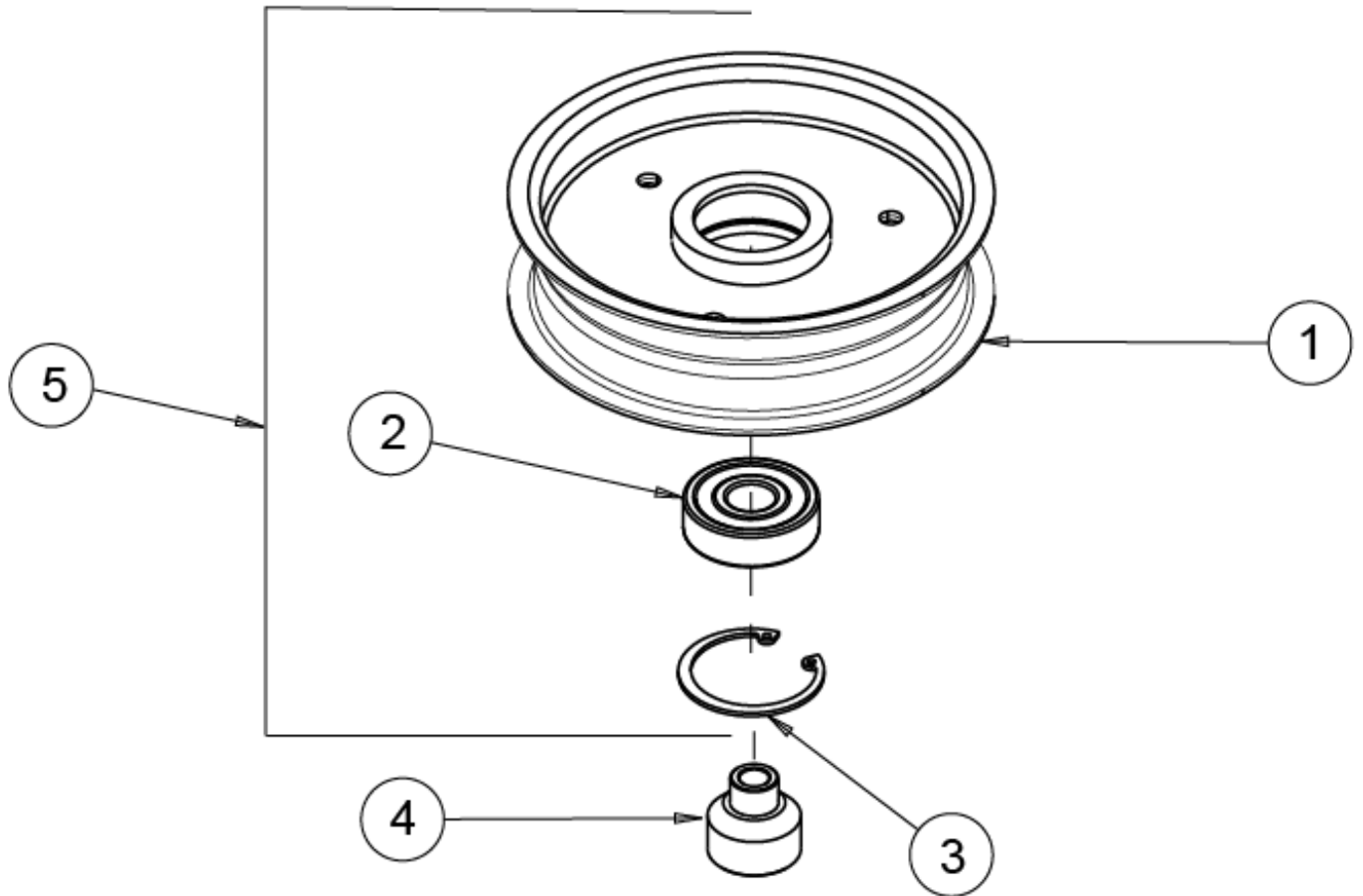

ITEM	PART NO.	DESCRIPTION
1	542137	IDLER, FLAT 150MM
2	B276-6303RS	BEARING 6303-2RS
3	B893.1-47	SNAP RING 47
4	543450	STAND-OFF, LG IDLER
5	542138	IDLER, FLAT 150MM, W/BEARING

## BRAKE CONTROL GROUP

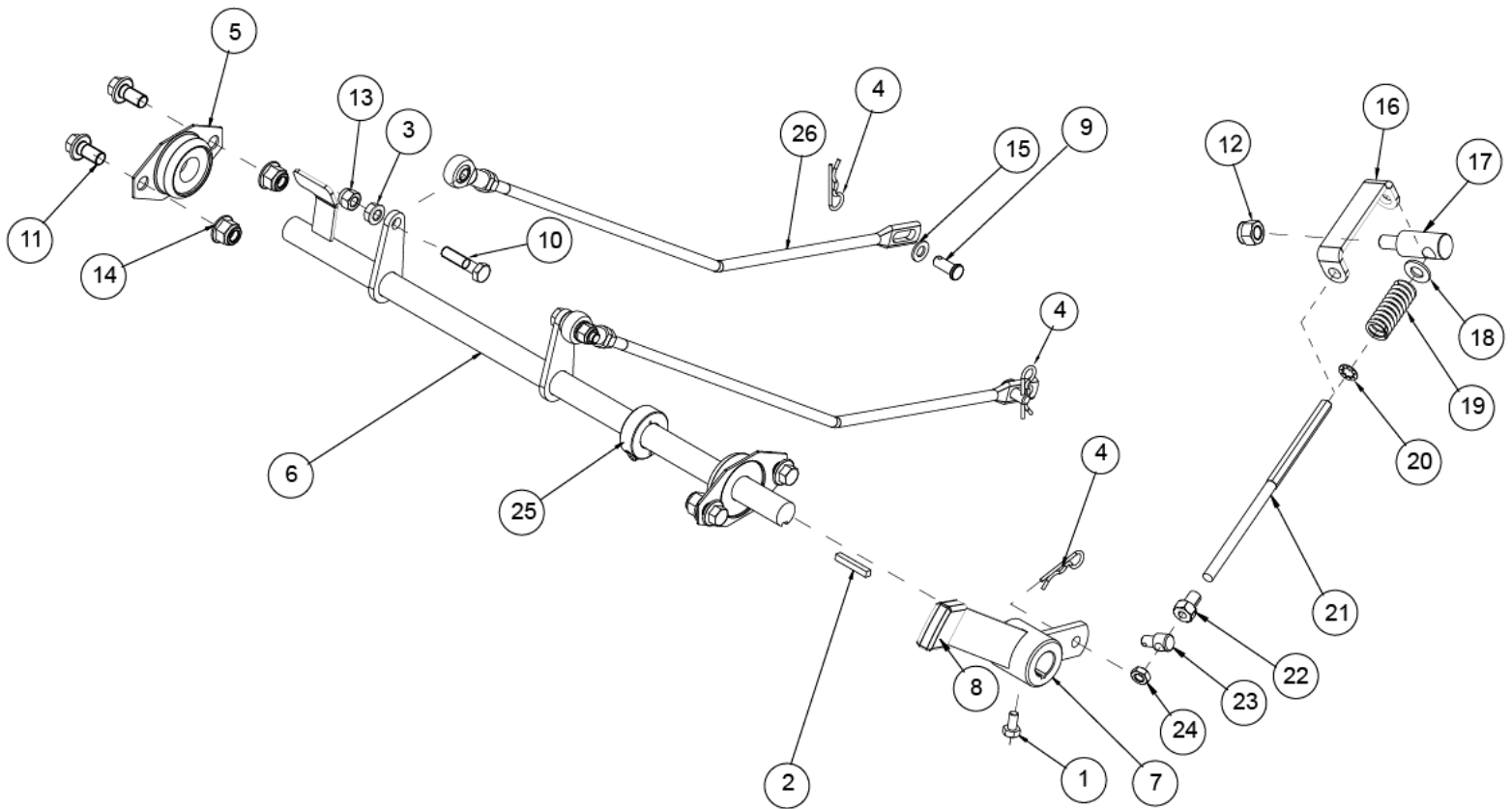

## BRAKE CONTROL GROUP

ITEM	PART NO	DESCRIPTION
1	100501	1/4-28 X 1/2 HHCS
2	107264	3/16 X 3/16 X 1-1/4 MACH KEY
3	B6177-8	NUT, WHIZLOCK M8
4	XSZ56-1-17	HAIR PIN
5	423140	3/4 I.D. 2 BOLT BEARING
6	632013	WLD, BRAKE SHAFT
7	632015	ASM, BRAKE LEVER
8	543300	GRIP, PARK BRAKE
9	B882B-820	PIN, 8 X 20 CLEVIS
10	B5782-835	BOLT M8X35
11	B5787-1020	SCREW, HH FLANGED M10 X 20
12	B6182-10	NUT, NYLOC M10
13	B6182-8	NUT, NYLOC M8
14	B6183-10	NUT, NYLOC FLANGE M10
15	B97.1-8	WASHER 8
16	593114	PARK BRAKE STRAP - PLATED
17	633116	SWIVEL, PARK BRAKE
18	105259	3/8 SAE FLAT WASHER
19	523024	SPRING, COMPRESSION
20	363117	BELT TENSION SPRING
21	463089	ROD, SHORT BRAKE
22	593116	BRAKE SPRING NUT – PLATED
23	463231	SWIVEL, PARK BRAKE ROD
24	104751	5/16-18 HEX JAM NUT
25	523138	3/4" CLAMP COLLAR
26	632019	ASM, BRAKE LINK

## ENGINE ASSEMBLY FR691

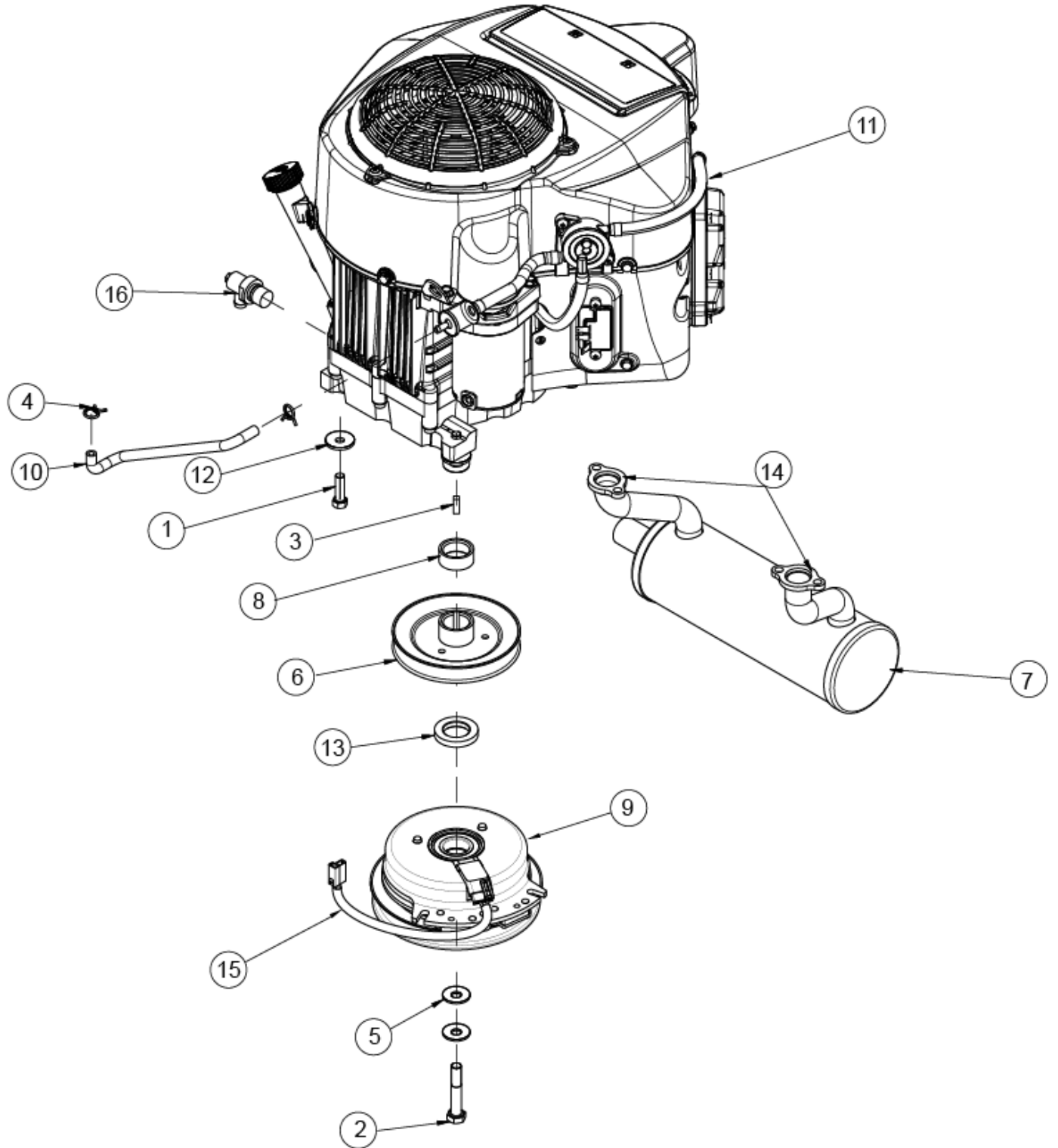

---

## ENGINE ASSEMBLY FR691

ITEM	PART NO.	DESCRIPTION
1	100293	3/8-16 x 1-1/4 HHCS
2	100535	7/16-20 X 2-1/2 HHCS
3	107258	1/4 X 1/4 X 3/4 MACH KEY
4	363098	CLAMP, FUEL LINE 1/4 ID
5	423069	SPRING DISC – 7/16
6	543003	SHEAVE, PUMP DRIVE
7	633033	MUFFLER, KAWASAKI FR691
8	633038	SPACER, ENGINE
9	633073	CLUTCH, 175LB
10	633099	HOSE, FUEL 1/4 X 14”
11	FOR REFERENCE ONLY	ENGINE, KAW FR691 (1-1/8" X 108.8MM)
12	753027	SPRING DISC WASHER
13	823248	CLUTCH SPACER 9/32
14	483098	MUFFLER GASKET
15	603083	CLUTCH ADAPT. HARNESS
16	343146	90 DEGREE DRAIN -KAW BLK



## ENGINE ASSEMBLY FS691

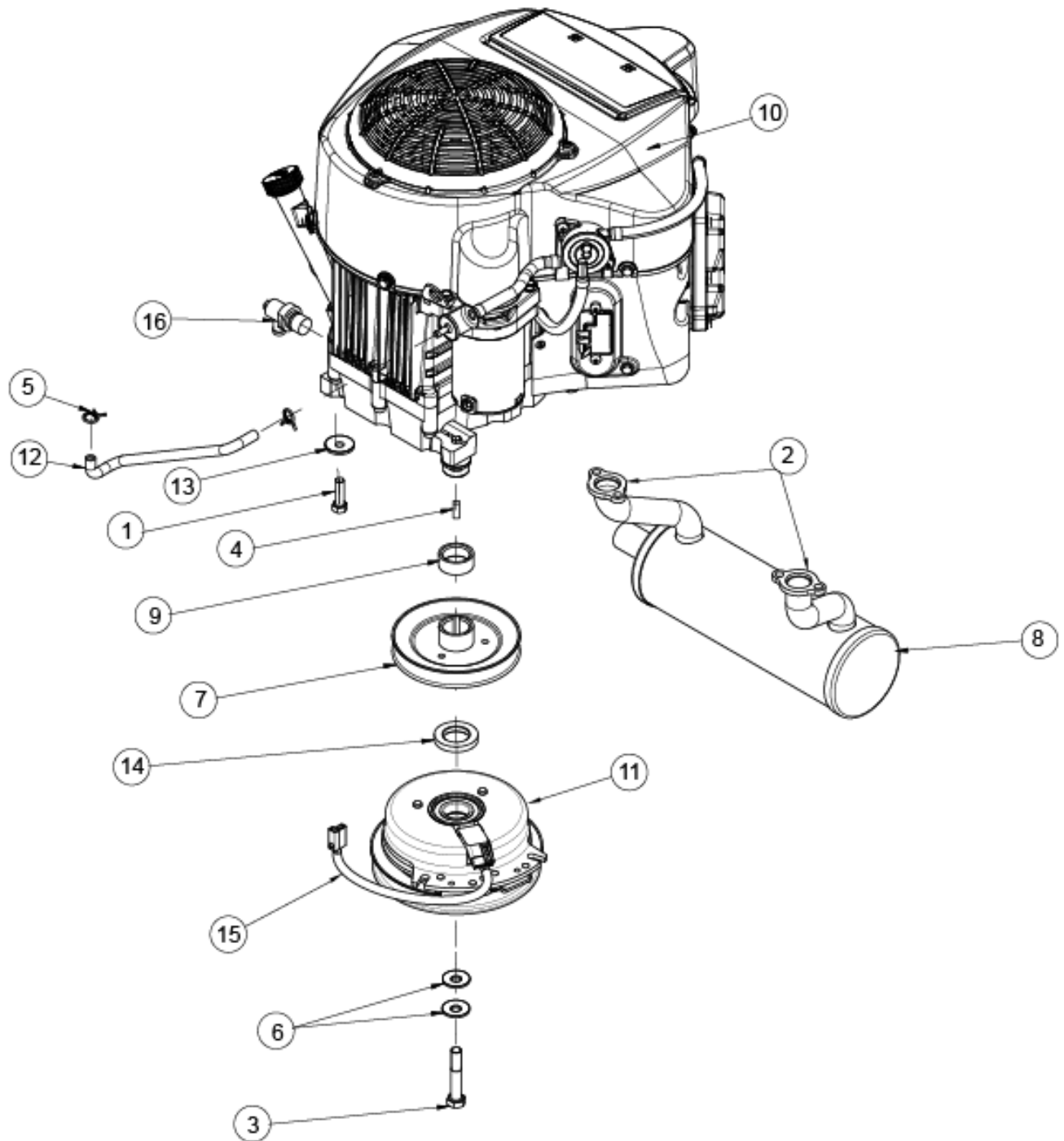

---



---

### ENGINE ASSEMBLY FS691

ITEM	PART NO.	DESCRIPTION
1	100293	3/8-16 X 1-1/4 HHCS
2	483098	MUFFLER GASKET
3	100535	7/16-20 X 2-1/2 HHCS
4	107258	1/4 X 1/4 X 3/4 MACH KEY
5	363098	CLAMP, FUEL LINE 1/4 ID
6	423069	SPRING DISC.- 7/16
7	543003	SHEAVE, PUMP DRIVE
8	633033	MUFFLER, KAWASAKI FR691
9	633038	SPACER, ENGINE
10	FOR REFERENCE ONLY	ENGINE, KAWASAKI FS691
11	633073	CLUTCH, 175 LB
12	633099	HOSE, FUEL 1/4 X 14"
13	753027	SPRING DISC WASHER
14	823248	CLUTCH SPACER 9/32
15	603083	CLUTCH ADAPT. HARNESS
16	343146	90 DEGREE DRAIN -KAW BLK

## ENGINE ASSEMBLY CT810

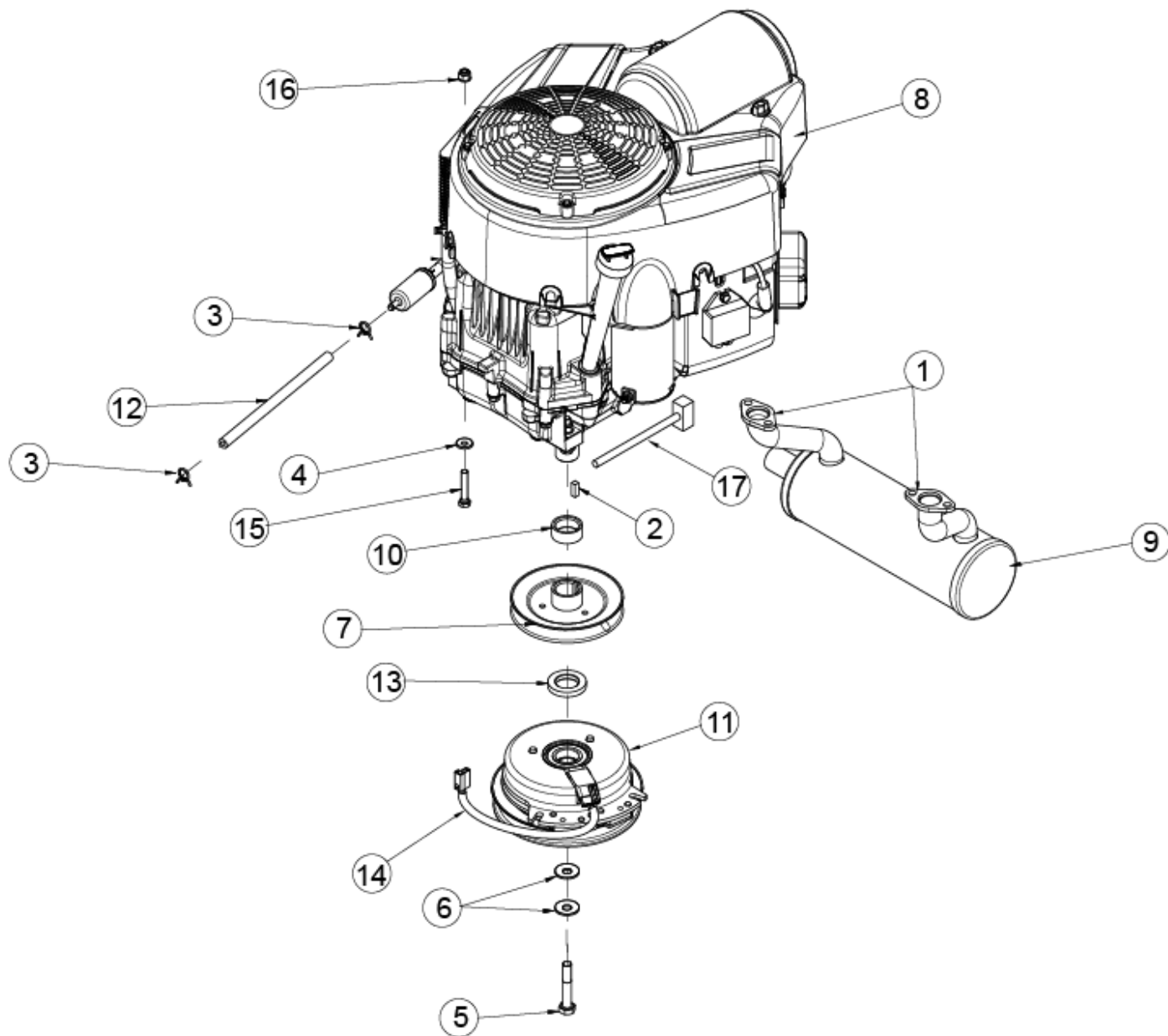

---



---

### ENGINE ASSEMBLY CT810

ITEM	PART NO	DESCRIPTION
1	483098	MUFFLER GASKET
2	107258	1/4 X 1/4 X 3/4 MACH KEY
3	363098	CLAMP, FUEL LINE 1/4 ID
4	363226	5/16 DISC SPRING
5	100535	7/16-20 X 2-1/2 HHCS
6	423069	SPRING DISC.- 7/16
7	543003	SHEAVE, PUMP DRIVE
8	FOR REFERENCE ONLY	ENGINE, BRIGGS 810cc COMM
9	633034	MUFFLER, BRIGGS 810 PS
10	633038	SPACER, ENGINE
11	633073	CLUTCH, 175 LB
12	633109	HOSE, FUEL 1/4 X 9
13	823248	CLUTCH SPACER 9/32
14	603083	CLUTCH ADAPT. HARNESS
15	B5783-845	BOLT M8 X 45
16	B6183-8	NUT, FLANGED NYLOC M8
17	5208033	HARNESS, 810 JUMPER

## ENGINE ASSEMBLY FX691

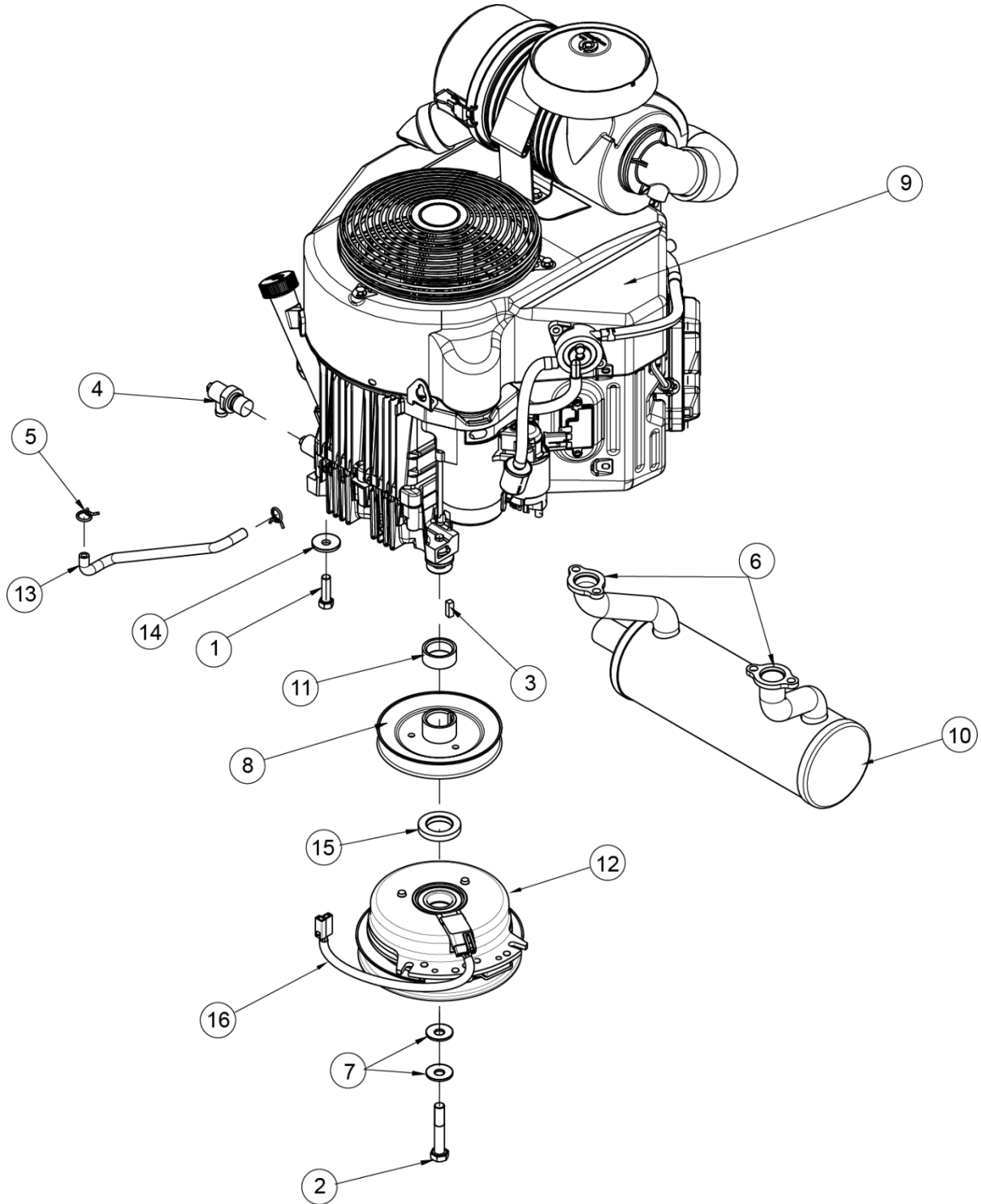

---

## ENGINE ASSEMBLY FX691

ITEM	PART NO.	DESCRIPTION
1	100293	3/8-16 X 1-1/4 HHCS
2	100535	7/16-20 X 2-1/2 HHCS
3	107258	1/4 X 1/4 X 3/4 MACH KEY
4	343146	90 DEGREE DRAIN -KAW BLK
5	363098	CLAMP, FUEL LINE 1/4 ID
6	483098	MUFFLER GASKET
7	423069	SPRING DISC. WASHER – 7/16
8	543003	SHEAVE, PUMP DRIVE
9	FOR REFERENCE ONLY	ENGINE, KAW FX691V
10	633033	MUFFLER, KAWASAKI FR691
11	633038	SPACER, ENGINE
12	633073	CLUTCH, 175LBS
13	633099	HOSE, FUEL 1/4 X 14”
14	753027	SPRING DISC WASHER
15	823248	CLUTCH SPACER 9/32
16	603083	CLUTCH ADAPT. HARNESS

## ENGINE ASSEMBLY FX730

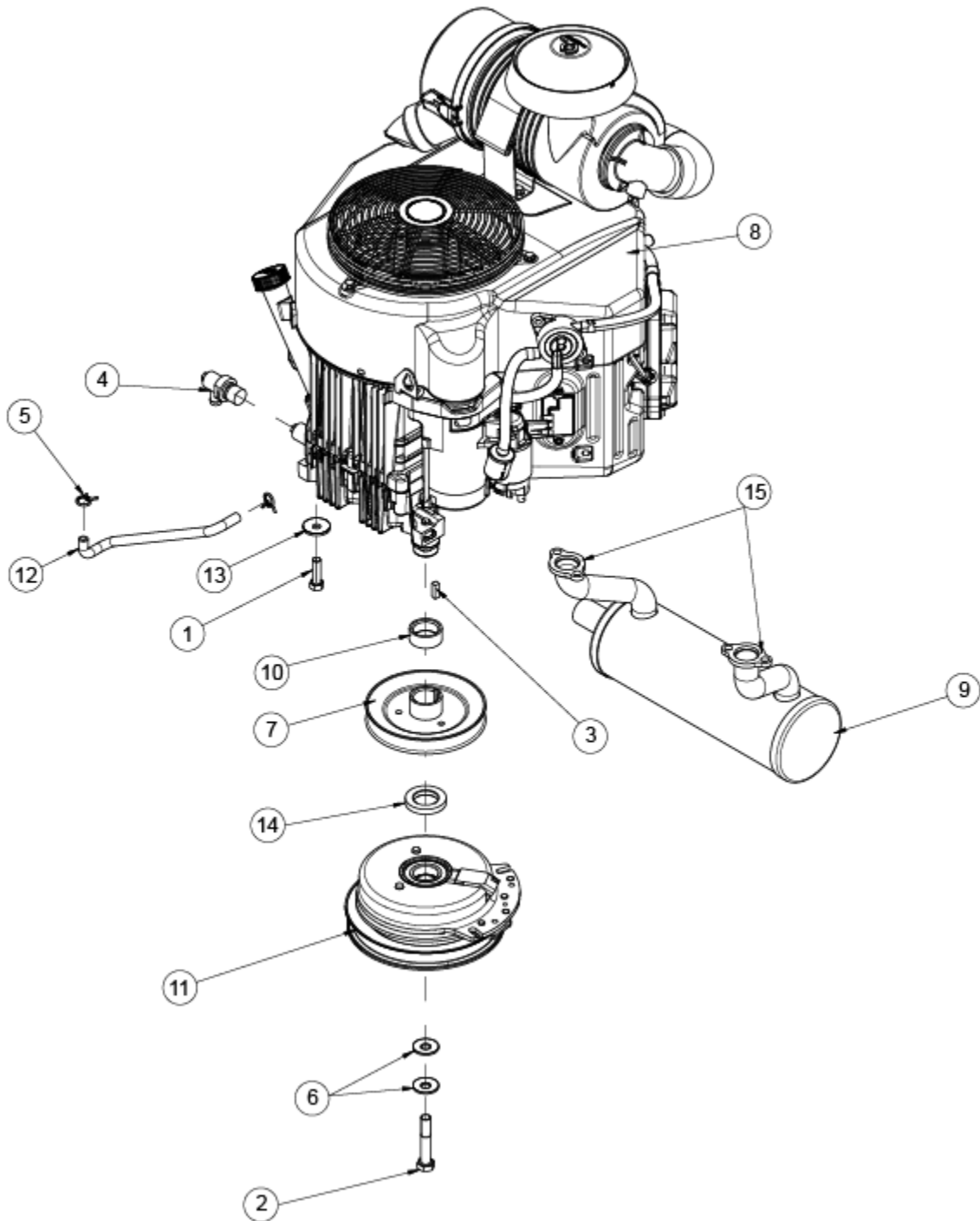

---

## ENGINE ASSEMBLY FX730

ITEM	PART NO.	DESCRIPTION
1	100293	3/8-16 X 1-1/4 HHCS
2	100535	7/16-20 X 2-1/2 HHCS
3	107258	1/4 X 1/4 X 3/4 MACH KEY
4	343146	90 DEGREE DRAIN -KAW BLK
5	363098	CLAMP, FUEL LINE 1/4 ID
6	423069	SPRING DISC. WASHER - 7/16
7	543003	SHEAVE, PUMP DRIVE
8	FOR REFERENCE ONLY	ENGINE, KAW FX730V
9	633033	MUFFLER, KAWASAKI FR691
10	633038	SPACER, ENGINE
11	633073	CLUTCH, 175 LB
12	633099	HOSE, FUEL 1/4 X 14"
13	753027	SPRING DISC WASHER
14	823248	CLUTCH SPACER 9/32
15	483098	MUFFLER GASKET - 19,21,23,25 KAW



## FUEL ASSEMBLY DIAMONDBACK

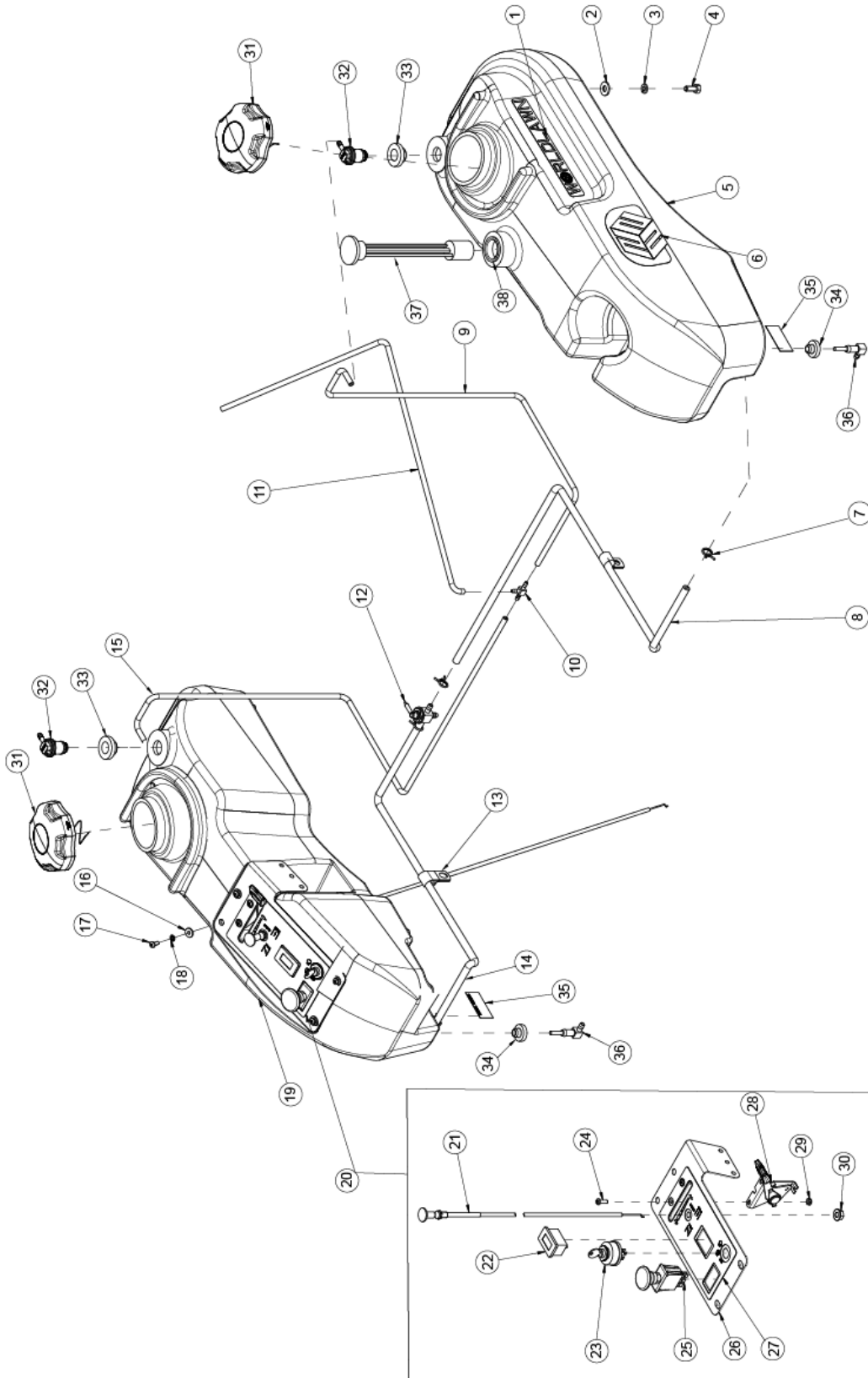

## FUEL ASSEMBLY DIAMONDBACK

ITEM	PART NO.	DESCRIPTION
1	463445	DECAL, WORLDLAWN W/GRN
2	105258	5/16 STD FLAT WASHER
3	105005	5/16 LOCKWASHER-HEAVY
4	100271	5/16-18 X 3/4 HHCS
5	632038	ASM, BLK FUEL TANK LP - LH
6	543383	DECAL, WORLDLAWN COLOR
7	363098	CLAMP, FUEL LINE 1/4 ID
8	633101	HOSE, FUEL 1/4 X 33"
9	633102	HOSE, VENT 3/16 X 29"
10	5204010	TEE, HOSE 3/16 ID
11	353223	HOSE, VENT 3/16 X 22"
12	583050	FUEL VALVE
13	603031	DRAIN CLAMP
14	633100	HOSE, FUEL 1/4 X 26"
15	543362	HOSE, VENT 3/16 ID X 36
16	5204044	BUSHING
17	5204045	SCREW 10-24 UNC X 1/2"
18	B861.1-5	INT TOOTH LOCKWASHER M5
19	632037	ASM, BLK FUEL TANK LP - RH
20	634018	GRP, BASIC CONTROL PANEL
21	633104	CHOKE CABLE
22	453417	METER, MS HOUR
23	423027	IGNITION SWITCH
NOT SHOWN	423413	KEY, COVERED IGNITION
NOT SHOWN	423414	NUT, 5/8-32 NYLON
NOT SHOWN	423415	WASHER, INTERNAL TOOTH, LOCK
NOT SHOWN	423416	BEZEL, 5/8 NUT
24	101039	#10-24 X 5/8 MACH SCREW
25	4807005	SWITCH, PTO
26	633097-1	CONSOLE, TANK PROSUMER, BLK
27	633105	DECAL, CONTROL PANEL
28	633103	THROTTLE CABLE
29	104252	#10-24 HEX NYLOC NUT
30	109008	3/8-24 WHIZLOCK NUT
31	363413	FUEL CAP - EPA/CARB
32	593370	REMOTE VENT
33	363412	VENT VALVE GROMMET
34	533125	VALVE GROMMET - VITON
35	593457	DECAL, EPA TANK DKA
36	583183	FUEL TANK ADAPTER
37	5204046	FUEL GAUGE
38	632051	KIT, FUEL GAGE GROMMET

## FUEL ASSEMBLY DIAMONDBACK – CA

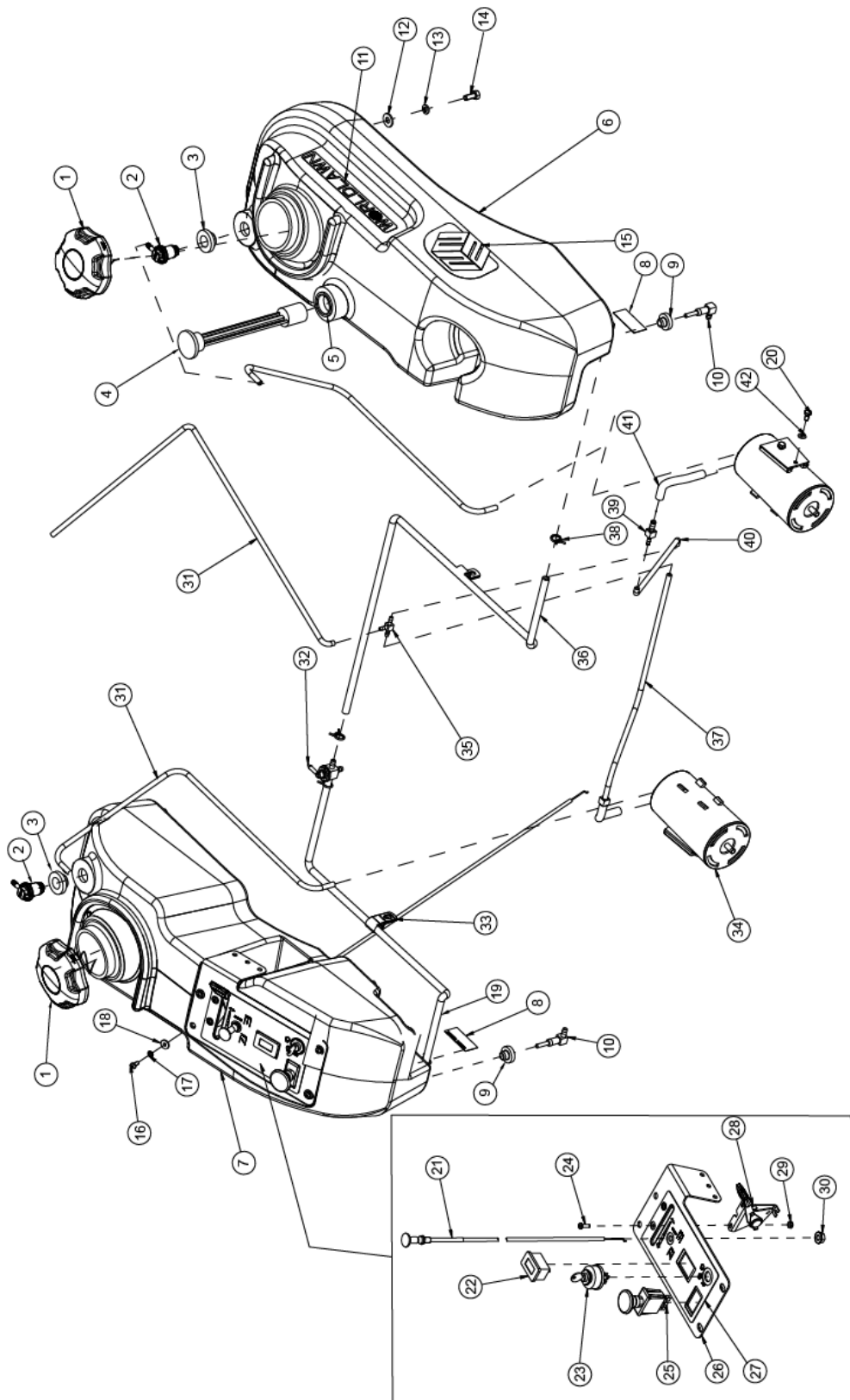

## FUEL ASSEMBLY DIAMONDBACK – CA

ITEM	PART NO.	DESCRIPTION
1	363413	FUEL CAP - EPA/CARB
2	593370	REMOTE VENT
3	363412	VENT VALVE GROMMET
4	5204046	FUEL GAUGE
5	632051	KIT, FUEL GAGE GROMMET
6	632038	ASM, BLK FUEL TANK LP - LH
7	632037	ASM, BLK FUEL TANK LP - RH
8	593457	DECAL, EPA TANK DKA
9	533125	VALVE GROMMET - VITON
10	583183	FUEL TANK ADAPTER
11	463445	DECAL, WORLDLAWN W/GRN
12	105258	5/16 STD FLAT WASHER
13	105005	5/16 LOCKWASHER-HEAVY
14	100271	5/16-18 X 3/4 HHCS
15	543383	DECAL, WORLDLAWN COLOR
16	5204045	SCREW 10-24 UNC X 1/2"
17	B861.1-5	INT TOOTH LOCKWASHER M5
18	5204044	BUSHING
19	633100	HOSE, FUEL 1/4 X 26"
20	B5783-612	SCREW, HH TAP M6x12
21	633104	CHOKE CABLE
22	453417	METER, MS HOUR
23	423027	IGNITION SWITCH
24	101039	#10-24 X 5/8 MACH SCREW
NOT SHOWN	423413	KEY, COVERED IGNITION
NOT SHOWN	423414	NUT, 5/8-32 NYLON
NOT SHOWN	423415	WASHER, INTERNAL TOOTH, LOCK
NOT SHOWN	423416	BEZEL, 5/8 NUT
25	4807005	SWITCH, PTO
26	633097-1	CONSOLE, TANK PROSUMER, BLK
27	633105	DECAL, CONTROL PANEL
28	633103	THROTTLE CABLE
29	104252	#10-24 HEX NYLOC NUT
30	109008	3/8-24 WHIZLOCK NUT
31	353223	HOSE, VENT 3/16 X 22"
32	583050	FUEL VALVE
33	603031	DRAIN CLAMP
34	543363	CANISTER, CARBON 680cc
35	5204010	TEE, HOSE 3/16 ID
36	633101	HOSE, FUEL 1/4 X 33"
37	543361	HOSE, VENT 3/16 ID X 15
38	363098	CLAMP, FUEL LINE 1/4 ID
39	5000130	REDUCER, HOSE 3/16 - 1/4
40	543372	HOSE, VENT 3/16 ID X 12
41	623414	HOSE, FUEL 1/4" ID X 4"
42	543326	WASHER, SPRING DISC 1/4

## FUEL ASSEMBLY DIAMONDBACK XL/MAXX

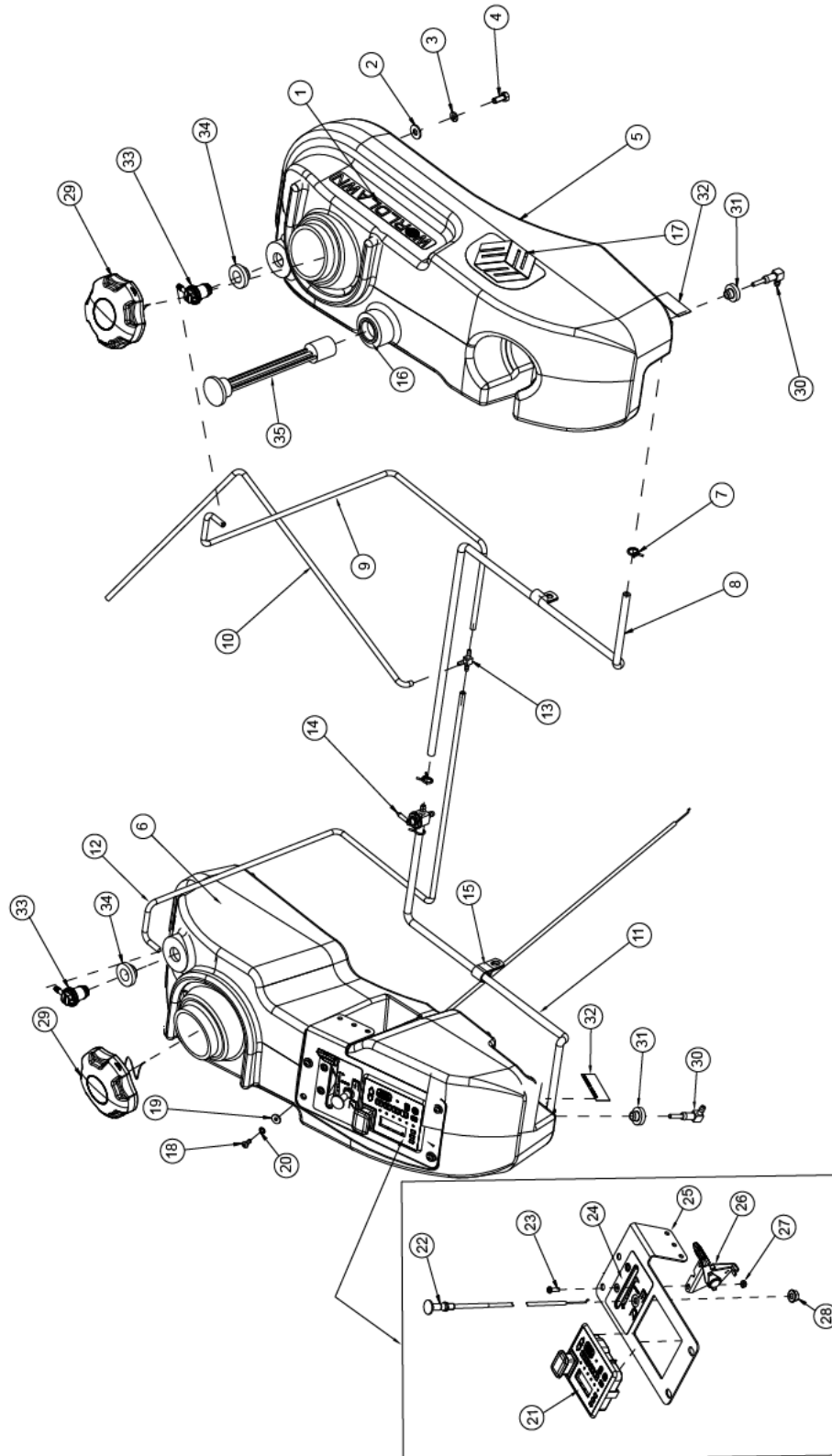

## FUEL ASSEMBLY DIAMONDBACK XL/MAXX

ITEM	PART NO.	DESCRIPTION
1	463445	DECAL, WORLDLAWN W/GRN
2	105258	5/16 STD FLAT WASHER
3	105005	5/16 LOCKWASHER-HEAVY
4	100271	5/16-18 X 3/4 HHCS
5	632038	ASM, BLK FUEL TANK LP - LH
6	632037	ASM, BLK FUEL TANK LP - RH
7	363098	CLAMP, FUEL LINE 1/4 ID
8	633101	HOSE, FUEL 1/4 X 33"
9	633102	HOSE, VENT 3/16 X 29"
10	353223	HOSE, VENT 3/16 X 22"
11	633100	HOSE, FUEL 1/4 X 26"
12	543362	HOSE, VENT 3/16 ID X 36
13	5204010	TEE, HOSE 3/16 ID
14	583050	FUEL VALVE
15	603031	DRAIN CLAMP
16	632051	KIT, FUEL GAGE GROMMET
17	543383	DECAL, WORLDLAWN COLOR
18	5204045	SCREW 10-24 UNC X 1/2"
19	5204044	BUSHING
20	B861.1-5	INT TOOTH LOCKWASHER M5
21	633225	CONSOLE, DIGITAL
22	633104	CHOKE CABLE - KAW
	423153	CHOKE CABLE - BRIGGS
23	101039	#10-24 X 5/8 MACH SCREW
24	633124	DECAL, DIGITAL CONSOLE
25	633076-1	CONSOLE, TANK - BLACK
26	633103	THROTTLE CABLE
27	104252	#10-24 HEX NYLOC NUT
28	109008	3/8-24 WHIZLOCK NUT
29	363413	FUEL CAP - EPA/CARB
30	583183	FUEL TANK ADAPTER
31	533125	VALVE GROMMET - VITON
32	593457	DECAL, EPA TANK DKA
33	593370	REMOTE VENT
34	363412	VENT VALVE GROMMET
35	5204046	FUEL GAUGE

# FUEL ASSEMBLY DIAMONDBACK XL/MAXX – CA

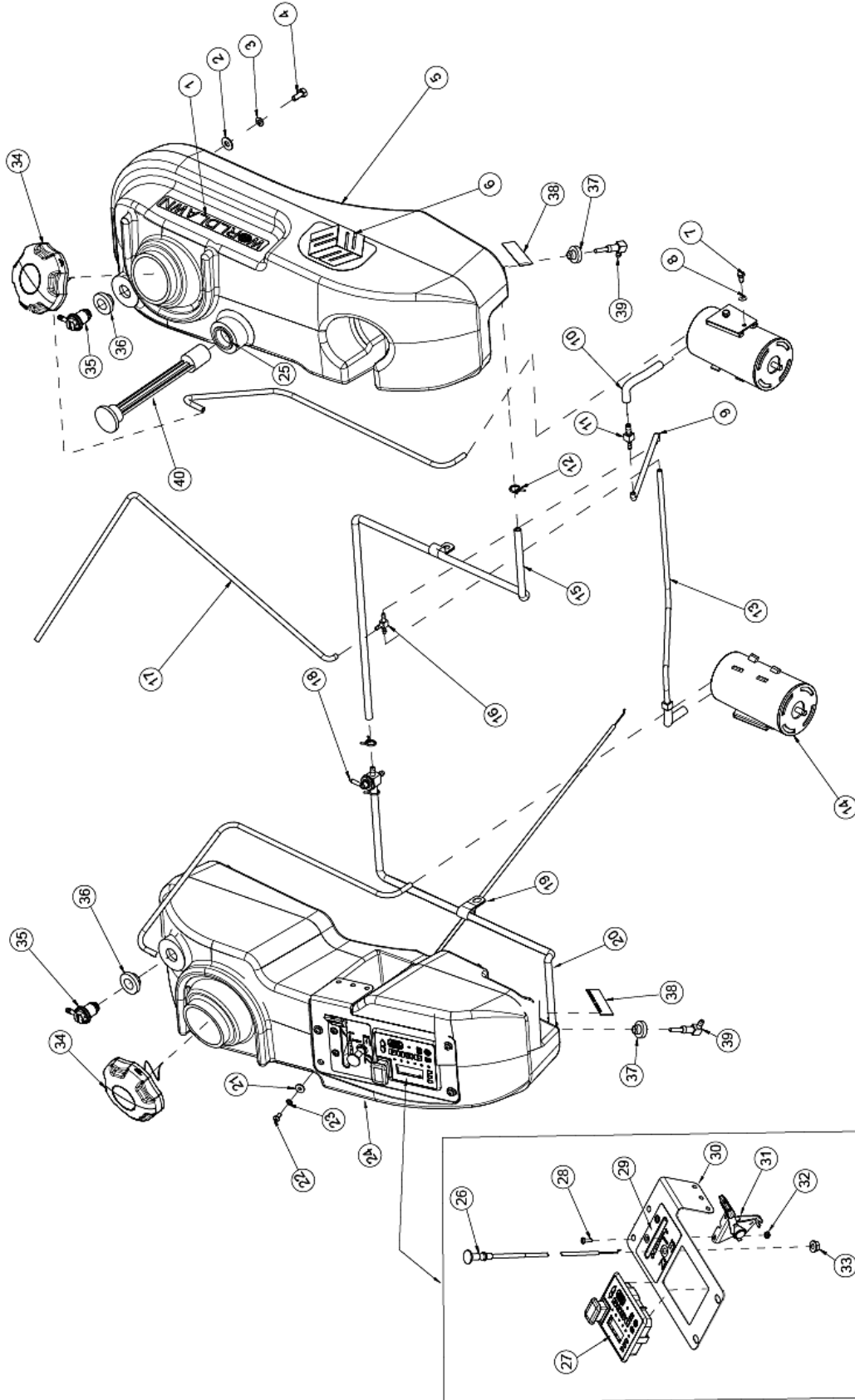

## FUEL ASSEMBLY DIAMONDBACK XL/MAXX – CA

ITEM	PART NO.	DESCRIPTION
1	463445	DECAL, WORLDLAWN W/GRN
2	105258	5/16 STD FLAT WASHER
3	105005	5/16 LOCKWASHER-HEAVY
4	100271	5/16-18 X 3/4 HHCS
5	632038	ASM, BLK FUEL TANK LP - LH
6	543383	DECAL, WORLDLAWN COLOR
7	B5783-612	SCREW, HH TAP M6x12
8	543326	WASHER, SPRING DISC 1/4
9	543372	HOSE, VENT 3/16 ID X 12
10	623414	HOSE, FUEL 1/4" ID X 4"
11	5000130	REDUCER, HOSE 3/16 - 1/4
12	363098	CLAMP, FUEL LINE 1/4 ID
13	543361	HOSE, VENT 3/16 ID X 15
14	543363	CANISTER, CARBON 680cc
15	633101	HOSE, FUEL 1/4 X 33"
16	5204010	TEE, HOSE 3/16 ID
17	353223	HOSE, VENT 3/16 X 22"
18	583050	FUEL VALVE
19	603031	DRAIN CLAMP
20	633100	HOSE, FUEL 1/4 X 26"
21	5204044	BUSHING
22	5204045	SCREW 10-24 UNC X 1/2"
23	B861.1-5	INT TOOTH LOCKWASHER M5
24	632037	ASM, BLK FUEL TANK LP - RH
25	632051	KIT, FUEL GAGE GROMMET
26	423153	CHOKE CABLE - BRIGGS
	633104	CHOKE CABLE - KAW
27	633225	CONSOLE, DIGITAL
28	101039	#10-24 X 5/8 MACH SCREW
29	633124	DECAL, DIGITAL CONSOLE
30	633076-1	CONSOLE, TANK - BLACK
31	633103	THROTTLE CABLE
32	104252	#10-24 HEX NYLOC NUT
33	109008	3/8-24 WHIZLOCK NUT
34	363413	FUEL CAP - EPA/CARB
35	593370	REMOTE VENT
36	363412	VENT VALVE GROMMET
37	533125	VALVE GROMMET – VITON
38	593457	DECAL, EPA TANK DKA
39	583183	FUEL TANK ADAPTER
40	5204046	FUEL GAUGE



## HYDRO ASSEMBLY

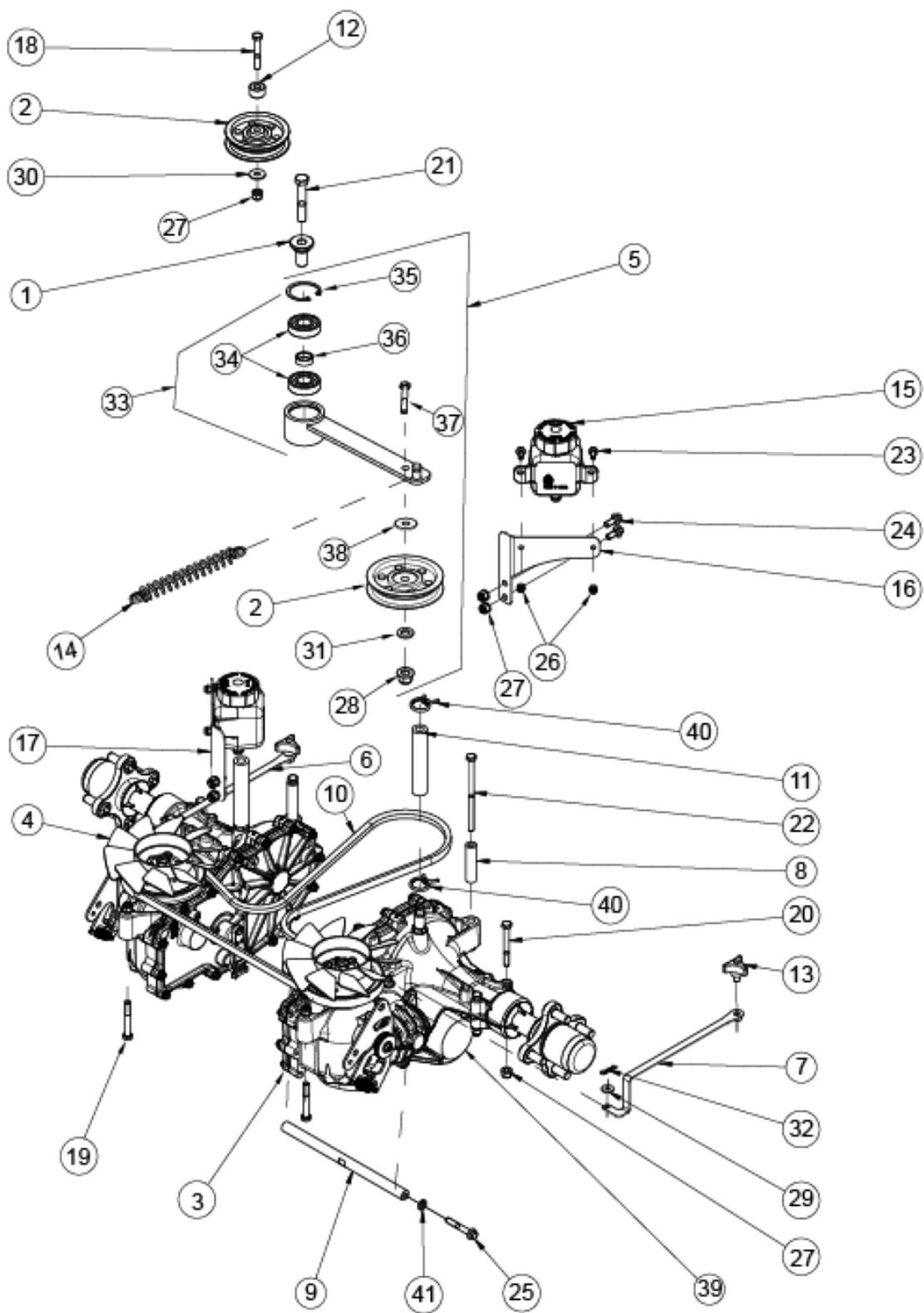

## HYDRO ASSEMBLY

ITEM	PART NO.	DESCRIPTION
1	453313	BUSHING, STEPPED
2	632058	ASM, 3.37 X .75 PULLEY W/ SPACER
3	543210	HYDRO, ZT 3400 LH
	633122	HYDRO, DB ZT 3200 LH
4	543211	HYDRO, ZT 3400 RH
	633121	HYDRO DB ZT 3200 RH
5	632017	ASM, HYDRO IDLER W/PULLEY
6	632020	WLD, HYDRO RELEASE RH
7	632021	WLD, HYDRO RELEASE LH
8	633030	HYDRO SPACER
9	633249	ROD, 20MM HYDRO SUPPORT
10	633061	BELT, HYDRO
11	633095	HOSE, 8TOC X 4.5
12	633108	SPACER
13	3302190	KNOB, 3-PRONGED W/STUD
14	4806004	IDLER SPRING
15	6012021	TANK, EXPANSION
16	633066-1	BRACKET, HYDRO TANK LH - BLACK
17	633067-1	BRACKET, HYDRO TANK RH - BLACK
18	B5782-855	HEX HD BOLT M8X55
19	B5782-860	HEX HD BOLT M8X60
20	B5782-870	BOLT M8X70
21	B5782-1270	SCREW, HH M12x70
22	B5782-8120	BOLT, M8 X 120
23	B5787-616	SCREW, HH FLANGE M6X16
24	B5787-820	SCREW, HH FLANGE M8X20
25	B5787-1055	BOLT M10 X 55
26	B6182-6	NUT, NYLOC M6
27	B6183-8	NUT, NYLOC M8
28	B6183-12	NUT, NYLOC FLANGE M12
29	B96-6	WASHER, FLAT LARGE M6
30	B96-8	WASHER 8
31	B97.1-12	WASHER 12
32	XSZ56-1-17	HAIR PIN
33	632022	ASM, HYDRO IDLER
34	B276-6203RS	BEARING 6203-2RS
35	B893.1-40	SNAP RING 40
36	5201077	BUSHING
37	B5782-845	BOLT M8X45
38	3303034	WASHER 8MM
39	H-71497	FILTER KIT
40	633248	CLAMP, 7/8" WIRE
41	B93-10	SPLIT LOCK WASHERM10

## ROPS ASSEMBLY

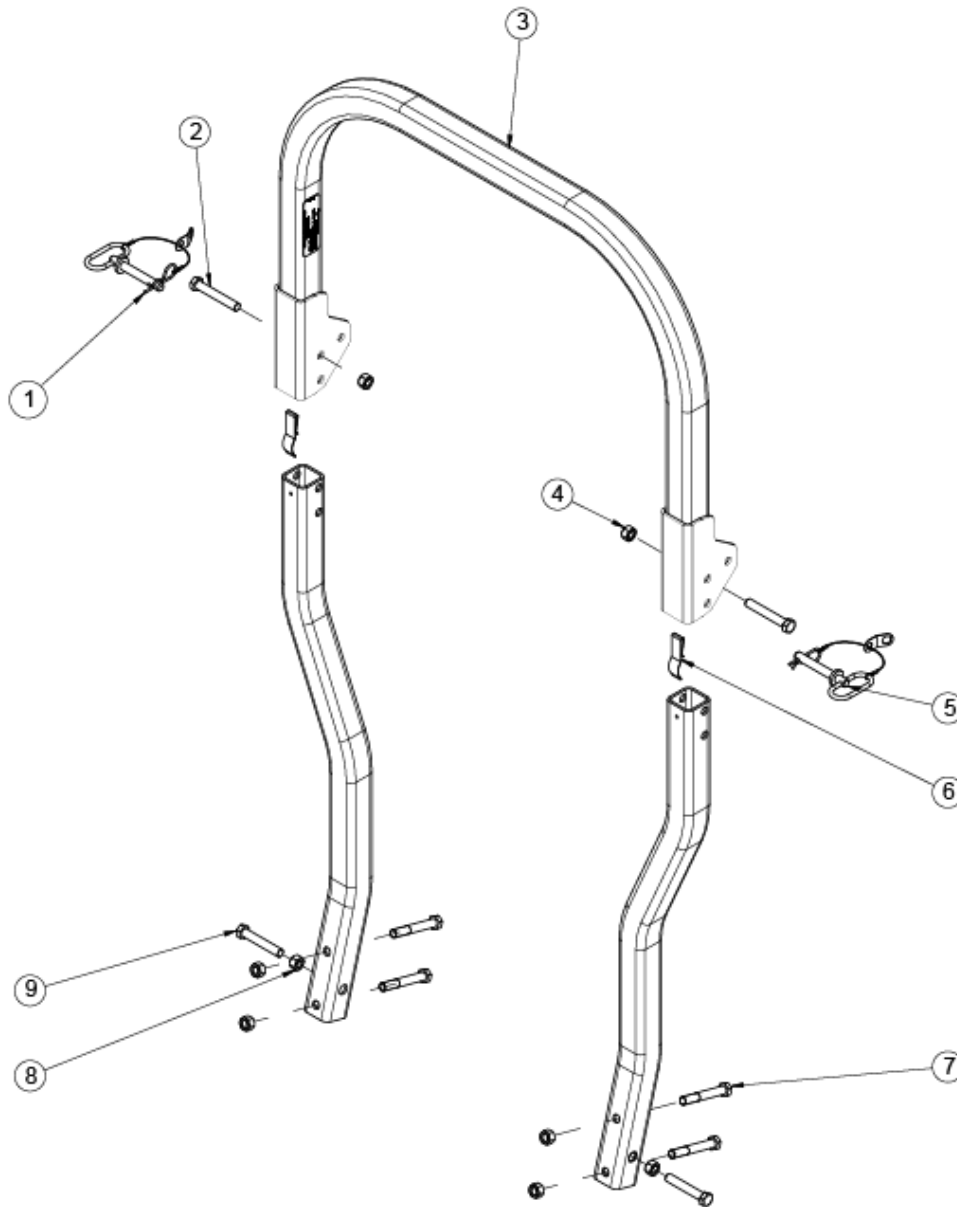

ITEM	PART NO.	DESCRIPTION
1	153025	#4 HAIRPIN COTTER
2	100332	SCREW, HH 1/2-13 X 3-1/4
3	632031	ROPS ASM
4	104259	1/2-13 HEX NYLOC NUT
5	543262	PIN, ROPS W/LANYARD
6	633152	SPRING, DB ROPS
7	100334	1/2-13 X 3-1/2 HHCS
8	104509	1/2-13 REG HEX NUT
9	100049	SCREW, HH TAP 1/2-13 X 3

## DIAMONDBACK BATTERY GROUP

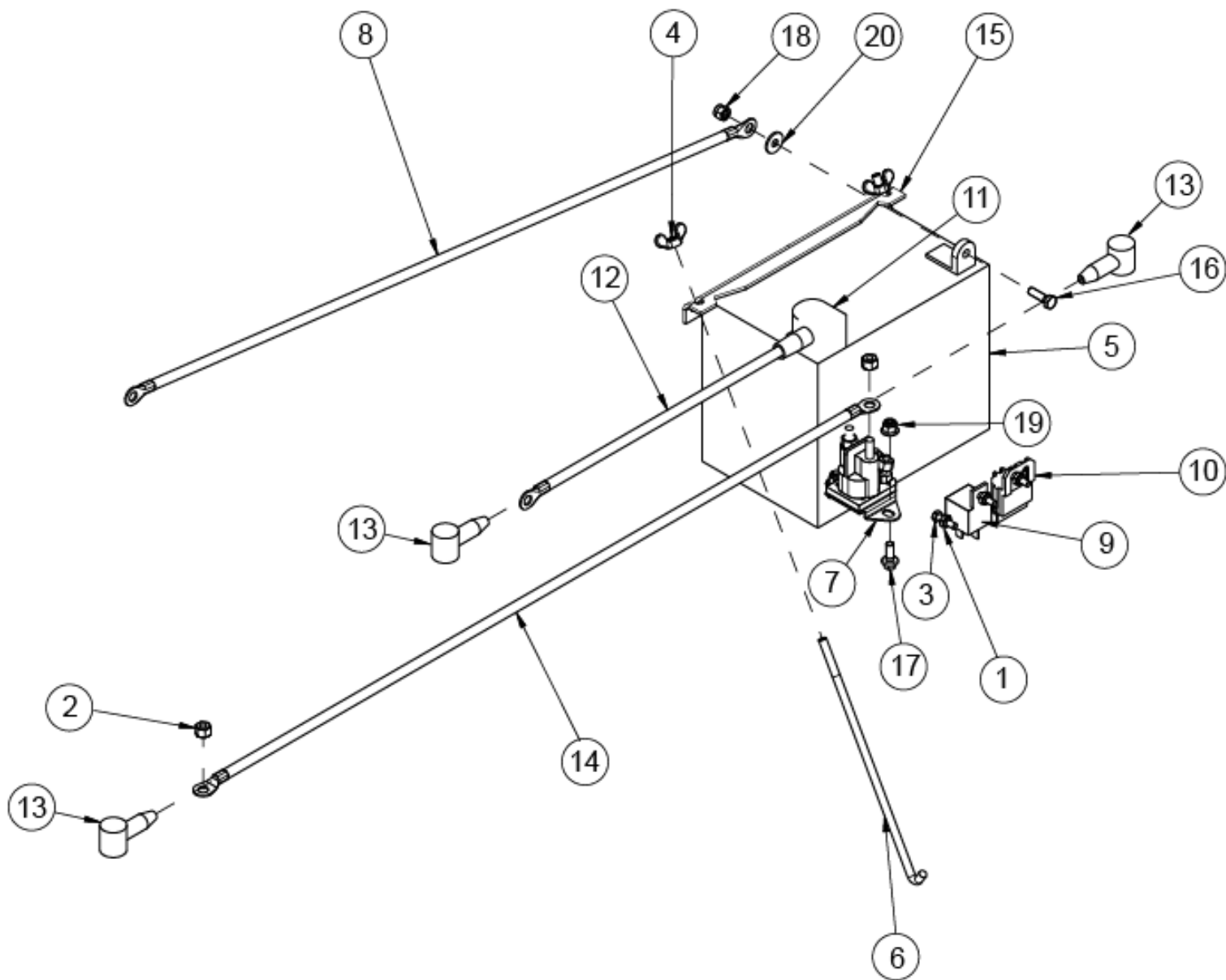

---



---

## DIAMONDBACK BATTERY GROUP

ITEM	PART NO.	DESCRIPTION
1	104252	#10-24 HEX NYLOC NUT
2	104255	1/4-20 HEX NYLOC NUT
3	109009	#10-24 X 3/4 HHCS
4	109012	1/4 WING NUT
5	FOR REFERENCE ONLY	BATTERY 12 V - U1 280CCA
6	423172	BATTERY HOLD DOWN ROD – PLATED
7	422150	STARTER RELAY W/TERMINALS
8	543330	CABLE, BATTERY NEGATIVE
9	583351	RELAY
10	583423	TIME DELAY MODULE
11	823199	BATTERY BOOT
12	2808106	CABLE, BATTERY POS
13	2808107	COVER
14	4807105	POSITIVE POLE CABLE-BATTERY
15	453419-1	BATTERY HOLD DOWN – BLACK
16	B5783-620	SCREW, HH TAP M6 X 20
17	B5787-616	SCREW, HH FLANGE M6 X 16
18	B6182-6	NUT, NYLOC M6
19	B6183.1-6	FLANGED LOCKNUT M6
20	B96-6	WASHER, FLAT LARGE M6
NOT SHOWN	633098	WIRE HARNESS SEE PG 56 FOR DETAIL

## DIAMONDBACK XL BATTERY GROUP

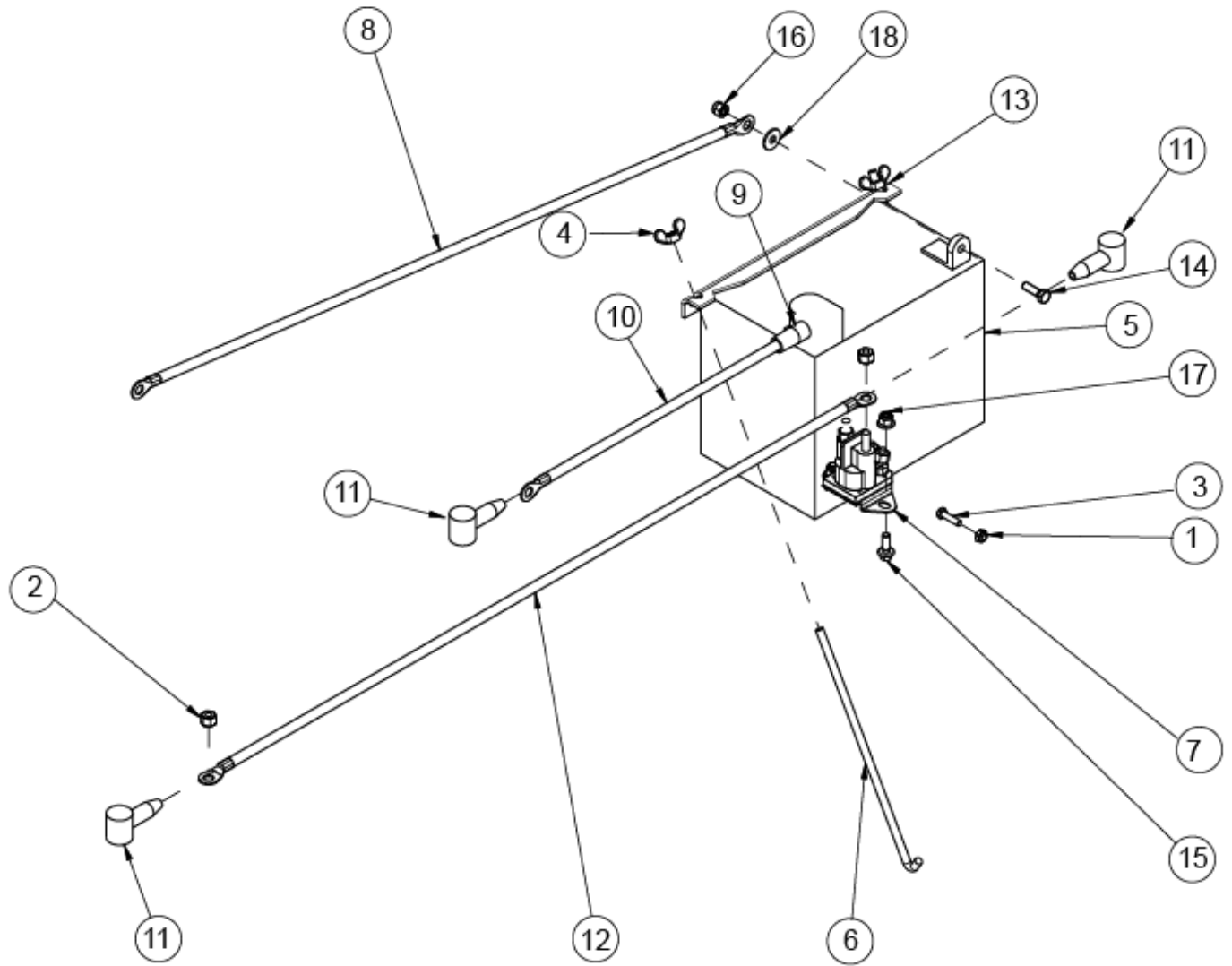

---

## DIAMONDBACK XL BATTERY GROUP

ITEM	PART NO.	DESCRIPTION
1	104252	#10-24 HEX NYLOC NUT
2	104255	1/4-20 HEX NYLOC NUT
3	109009	#10-24 X 3/4 HHCS
4	109012	1/4 WING NUT
5	FOR REFERENCE ONLY	BATTERY 12 V – U1 280 CCA
6	423172	BATTERY HOLD DOWN ROD – PLATED
7	422150	STARTER RELAY – WP W/TERMINALS
8	543330	CABLE, BATTERY NEGATIVE
9	823199	BATTERY BOOT
10	2808106	CABLE, BATTERY POS
11	2808107	COVER
12	4807105	POSITIVE POLE CABLE – BATTERY
13	453419-1	BATTERY HOLD DOWN – BLACK
14	B5783-620	SCREW, HH TAP M6 X 20
15	B5787-616	SCREW, HH FLANGE M6 X 16
16	B6182-6	NUT, NYLOC M6
17	B6183.1-6	FLANGED LOCKNUT M6
18	B96-6	WASHER, FLAT LARGE M6
NOT SHOWN	633221	XL HARNESS, MF CONTROL PANEL DETAIL ON PG 57

## DIAMONDBACK MAXX BATTERY GROUP

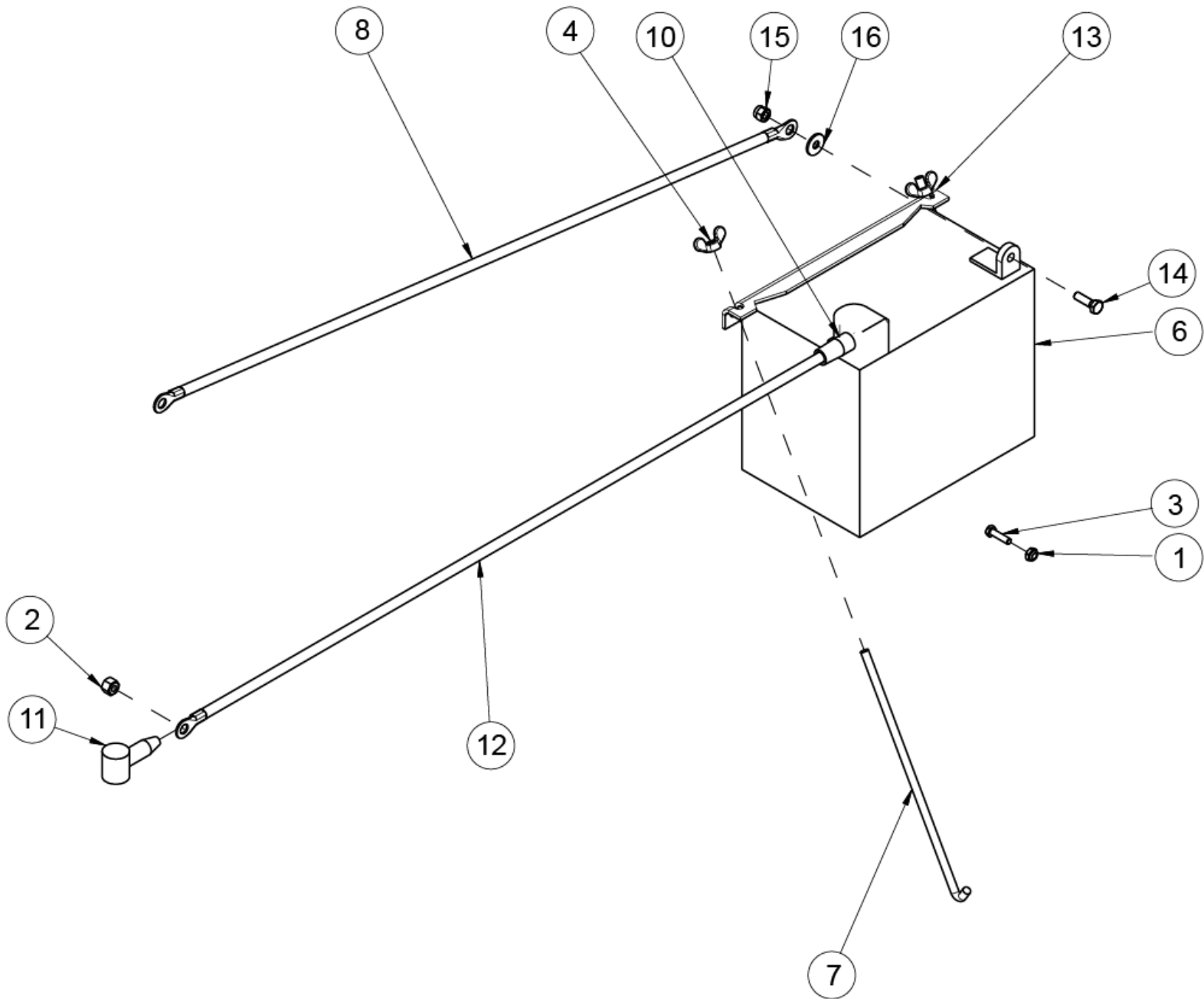



---



---

## DIAMONDBACK MAXX BATTERY GROUP

ITEM	PART NO.	DESCRIPTION
1	104252	#10-24 HEX NYLOC NUT
2	104255	1/4-20 HEX NYLOC NUT
3	109009	#10-24 X 3/4 HHCS
4	109012	1/4 WING NUT
5	363222	PLASTIC TIE
6	FOR REFERENCE ONLY	BATTERY 12V – U1 280 CCA
7	423172	BATTERY HOLD DOWN ROD - PLATED
8	543330	CABLE, BATTERY NEGATIVE
9	633251	HARNESS, FX691 DIGITAL PANEL – DETAIL PG 58
10	823199	BATTERY BOOT
11	2808107	COVER
12	4807105	POSITIVE POLE CABLE-BATTERY
13	453419-1	BATTERY HOLD DOWN - BLACK
14	B5783-620	SCREW, HH TAP M6x20
15	B6182-6	NUT, NYLOC M6
16	B96-6	WASHER, FLAT LARGE M6

## DIAMONDBACK XE BATTERY GROUP

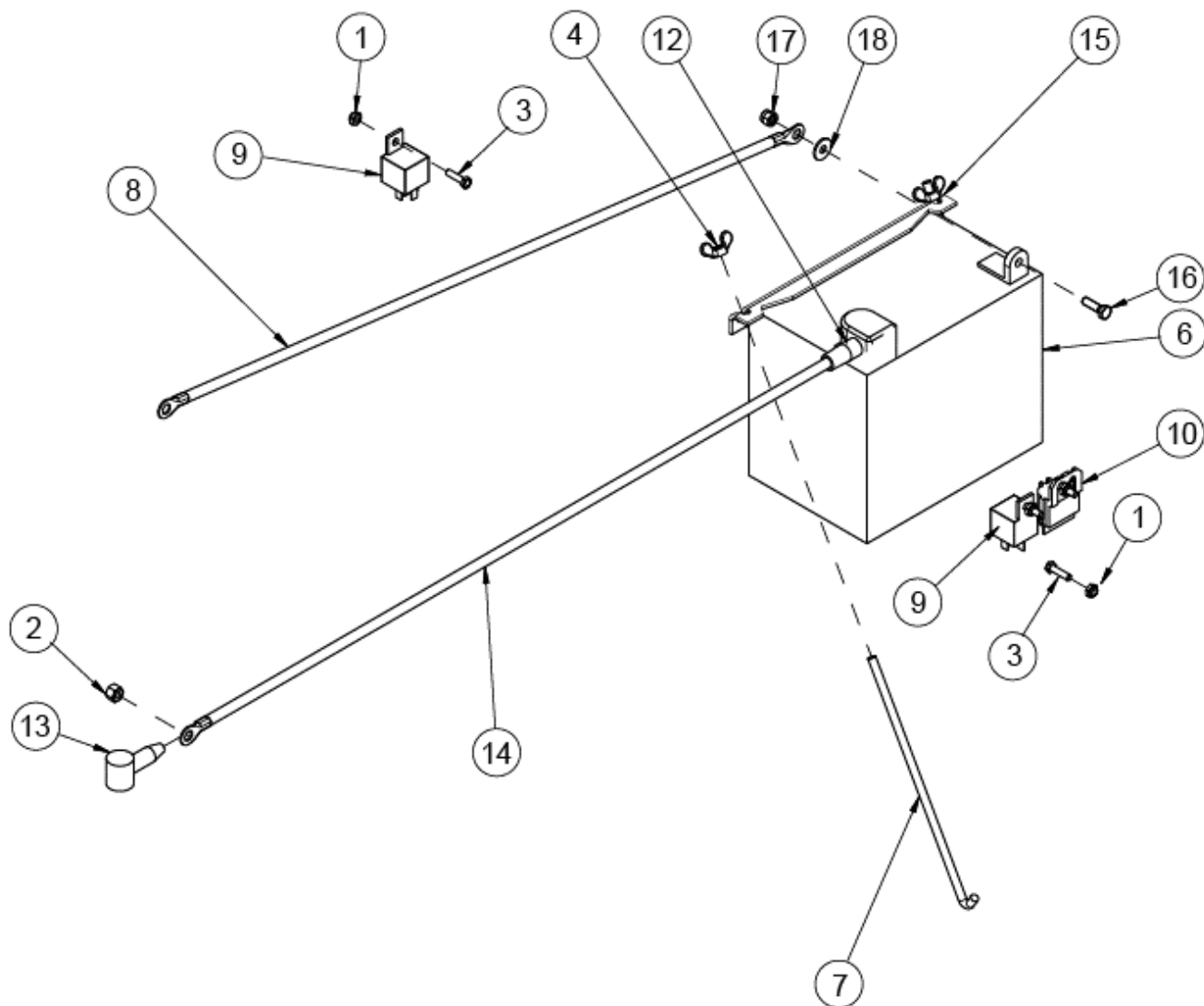

---

## DIAMONDBACK XE BATTERY GROUP

ITEM	PART NO.	DESCRIPTION
1	104252	#10-24 HEX NYLOC NUT
2	104255	1/4-20 HEX NYLOC NUT
3	109009	#10-24 X 3/4 HHCS
4	109012	1/4 WING NUT
5	363222	PLASTIC TIE
6	FOR REFERENCE ONLY	BATTERY 12V
7	423172	BATTERY HOLD DOWN ROD - PLATED
8	543330	CABLE, BATTERY NEGATIVE
9	583351	RELAY
10	583423	TIME DELAY MODULE
11	633274 – NOT SHOWN	HARNES, BASIC FX SEE PG 63 FOR DETAIL
12	823199	BATTERY BOOT
13	2808107	COVER
14	4807105	POSITIVE POLE CABLE-BATTERY
15	453419-1	BATTERY HOLD DOWN - BLACK
16	B5783-620	SCREW, HH TAP M6x20
17	B6182-6	NUT, NYLOC M6
18	B96-6	WASHER, FLAT LARGE M6

## DIAMONDBACK WIRING HARNESS

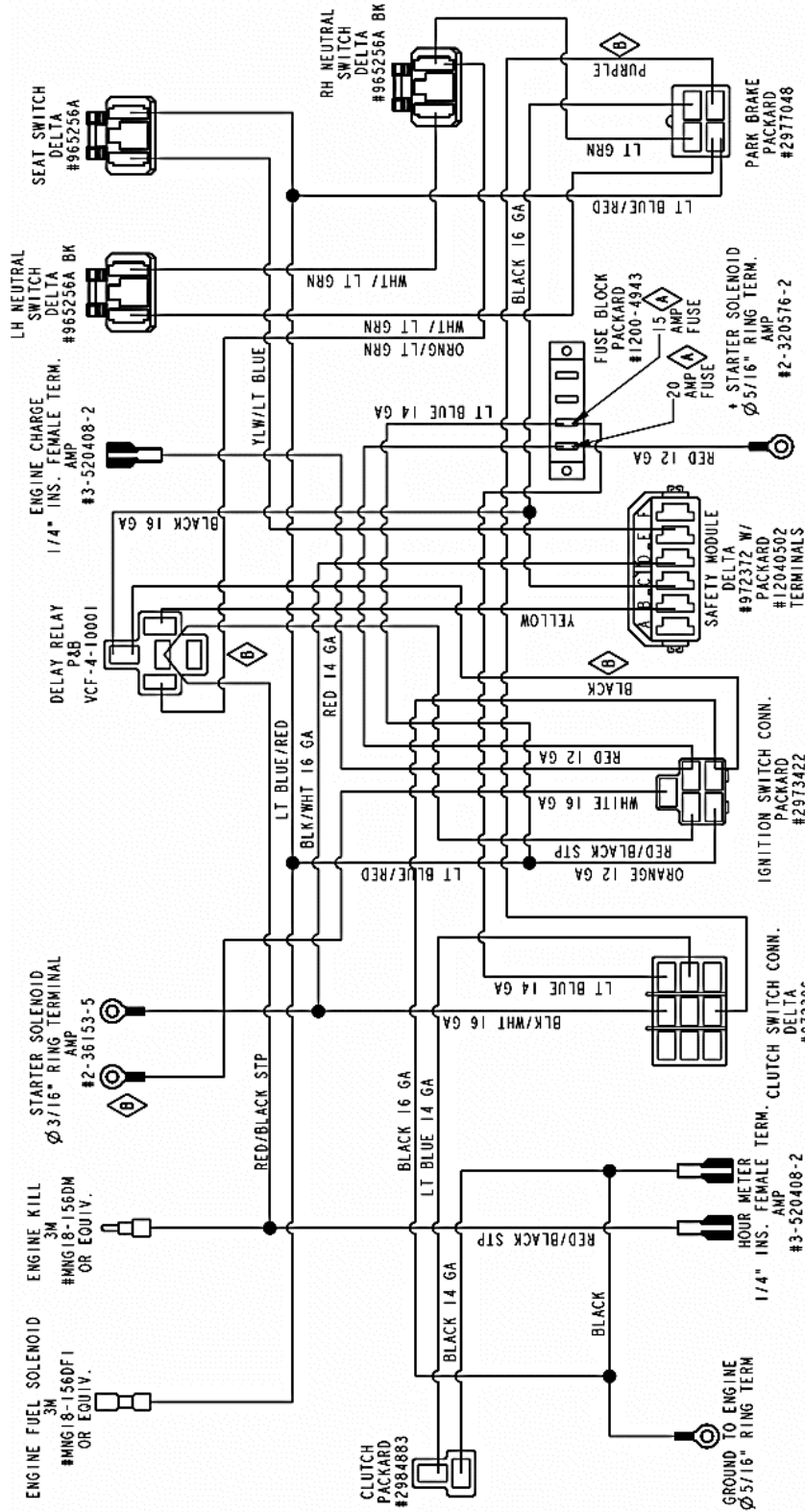

- NOTES:**
1. ALL WIRE IS 18 GA. UNLESS NOTED OTHERWISE
  2. ALL WIRE TERMINALS AND CONNECTIONS ARE TO BE PER NMA/ABC ENGINEERING SPECIFICATIONS
  3. ALL LIKE COLORED WIRES MUST BE ELECTRONICALLY CONNECTED UNLESS CIRCUIT CODING SHOWS OTHERWISE.
  4. ALL TERMINALS ARE TO BE SIZED TO THE GAUGE OF WIRE THEY ARE BEING INSTALLED ON.
  5. ALL HOUSINGS AND MOLDED PLUGS THAT SHOW PIN POSITION ARE FROM REAR (WIRE SIDE) VIEW.

## DIAMONDBACK XL WIRING HARNESS

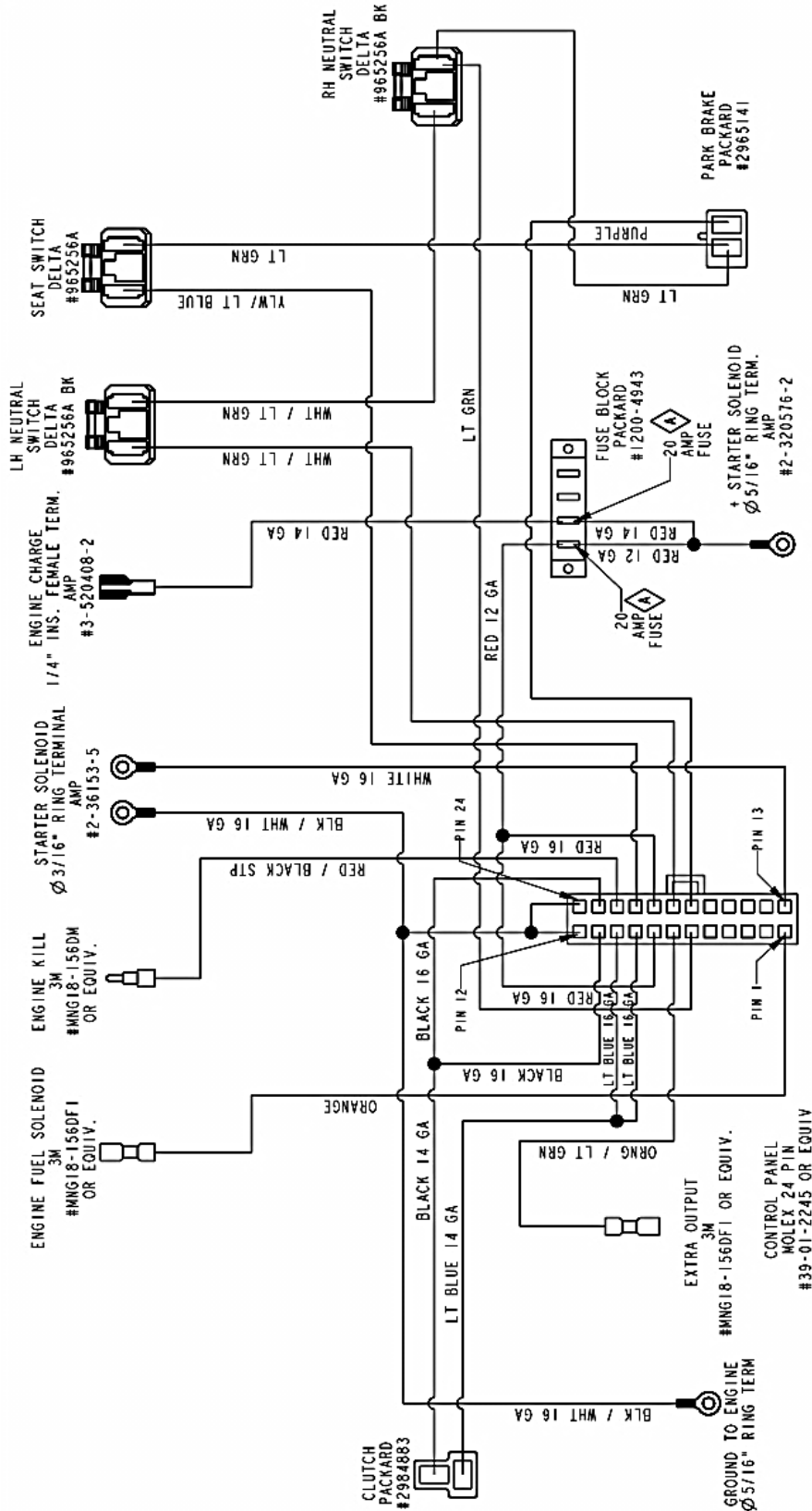

- NOTES:**
1. ALL WIRE IS 18 GA. UNLESS NOTED OTHERWISE
  2. ALL WIRE TERMINALS AND CONSTRUCTION ARE TO BE PER NMA/ABYC ENGINEERING SPECIFICATIONS
  3. ALL LIKE COLORED WIRES MUST BE ELECTRONICALLY CONNECTED UNLESS CIRCUIT CODING SHOWS OTHERWISE.
  4. ALL TERMINALS ARE TO BE SIZED TO THE GAUGE OF WIRE THEY ARE BEING INSTALLED ON.
  5. ALL HOUSINGS AND MOLDED PLUGS THAT SHOW PIN POSITION ARE FROM REAR (WIRE SIDE) VIEW.

# DIAMONDBACK MAXX WIRING HARNESS

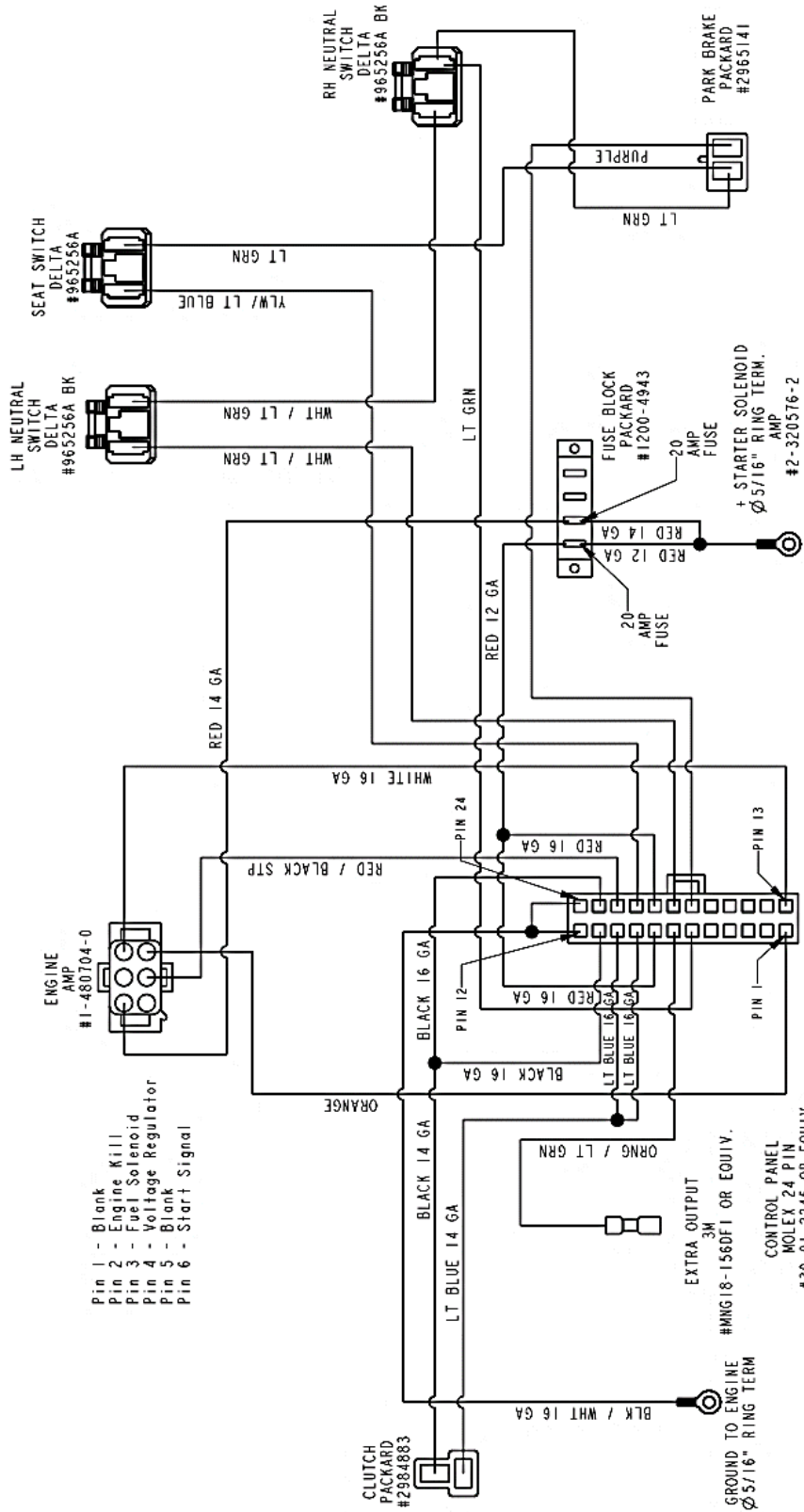

- NOTES:**
1. ALL WIRE IS 18 GA. UNLESS NOTED OTHERWISE
  2. ALL WIRE, TERMINALS AND CONSTRUCTION ARE TO BE PER NMMA/ABYC ENGINEERING SPECIFICATIONS.
  3. ALL LIKE COLORED WIRES MUST BE ELECTRONICALLY CONNECTED UNLESS CIRCUIT CODING SHOWS OTHERWISE.
  4. ALL TERMINALS ARE TO BE SIZED TO THE GAUGE OF WIRE THEY ARE BEING INSTALLED ON.
  5. ALL HOUSINGS AND MOLDED PLUGS THAT SHOW PIN POSITION ARE FROM REAR (WIRE SIDE) VIEW.

# DIAMONDBACK XE WIRING HARNESS

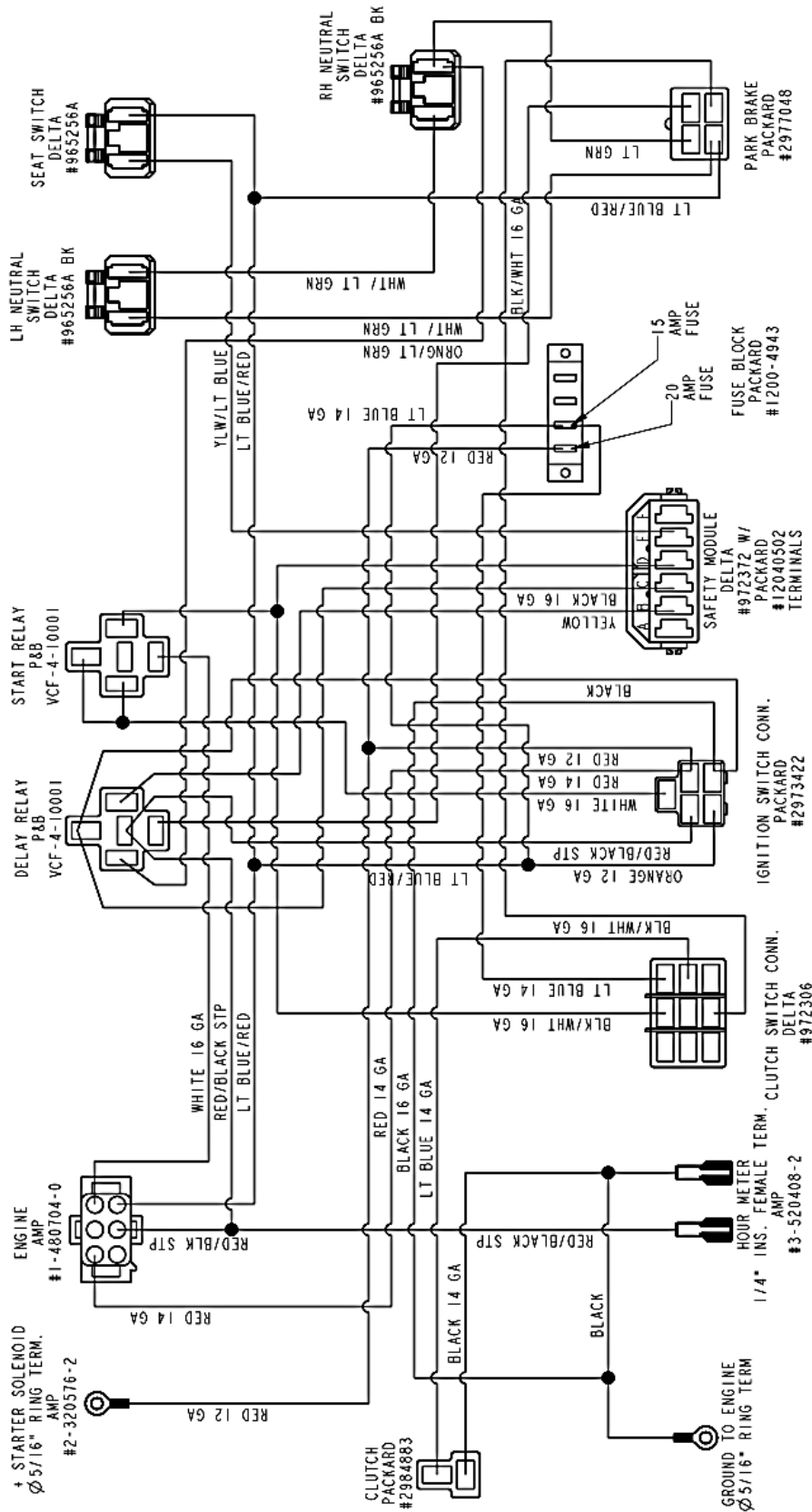

- NOTES:
1. ALL WIRE IS 18 GA. UNLESS NOTED OTHERWISE
  2. ALL WIRE, TERMINALS AND CONNECTION ARE TO BE PER NMMA/ABYC ENGINEERING SPECIFICATIONS.
  3. ALL LIKE COLORED WIRES MUST BE ELECTRONICALLY CONNECTED UNLESS CIRCUIT CODING SHOWS OTHERWISE.
  4. ALL TERMINALS ARE TO BE SIZED TO THE GAUGE OF WIRE THEY ARE BEING INSTALLED ON.
  5. ALL HOUSINGS AND MOLDED PLUGS THAT SHOW PIN POSITION ARE FROM REAR (WIRE SIDE) VIEW.

## DECAL GROUP



8008



8303

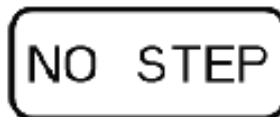

8304



453389



453390



543380



8324



8307



363023



8318



543392



543397



543391



543396



**DECAL GROUP**

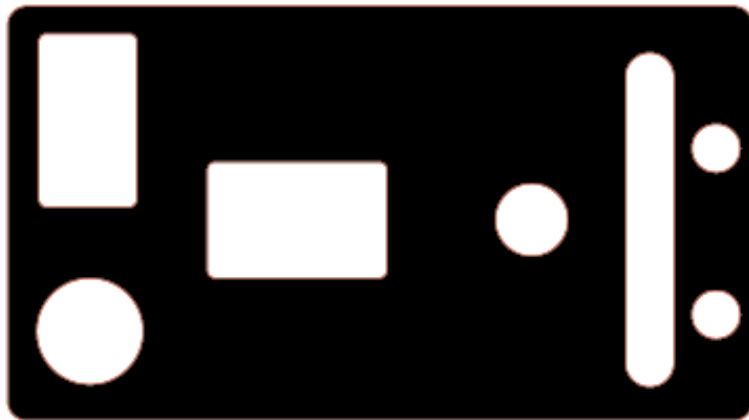

633105

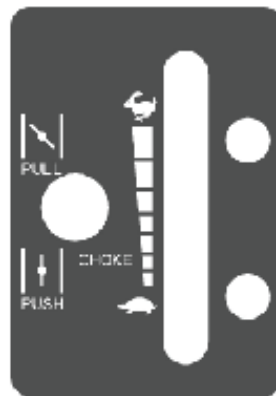

633124

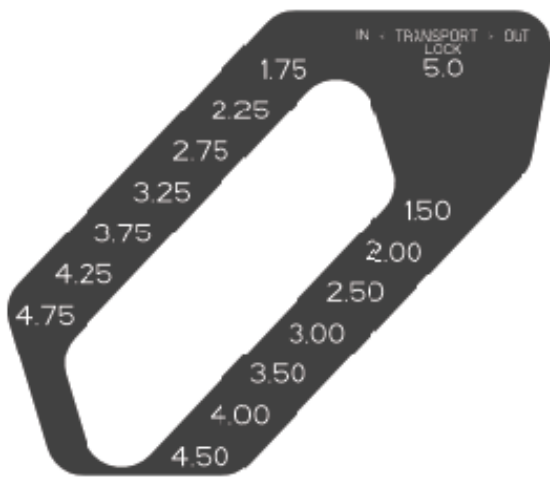

633106

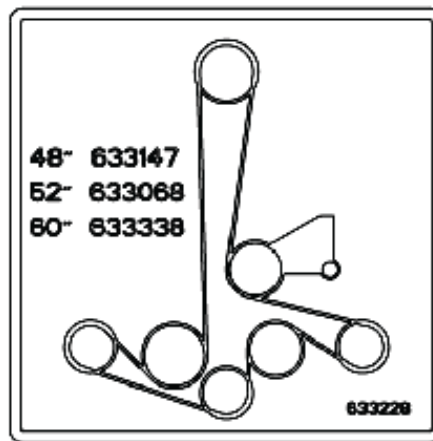

48" 633147  
52" 633068  
60" 633338

633228

633228



543401

WORLDLAWN

463445

WORLDLAWN

463444

WORLDLAWN

633236

DECAL GROUP



8328



8326



8327



543383



543379



633230



633222



633231



633276



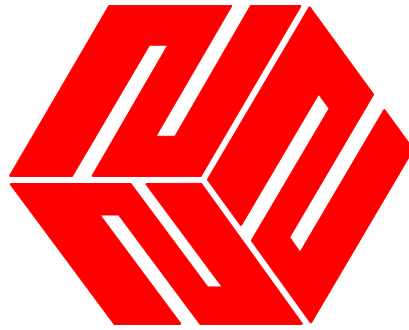

**WORLDLAWN®**