

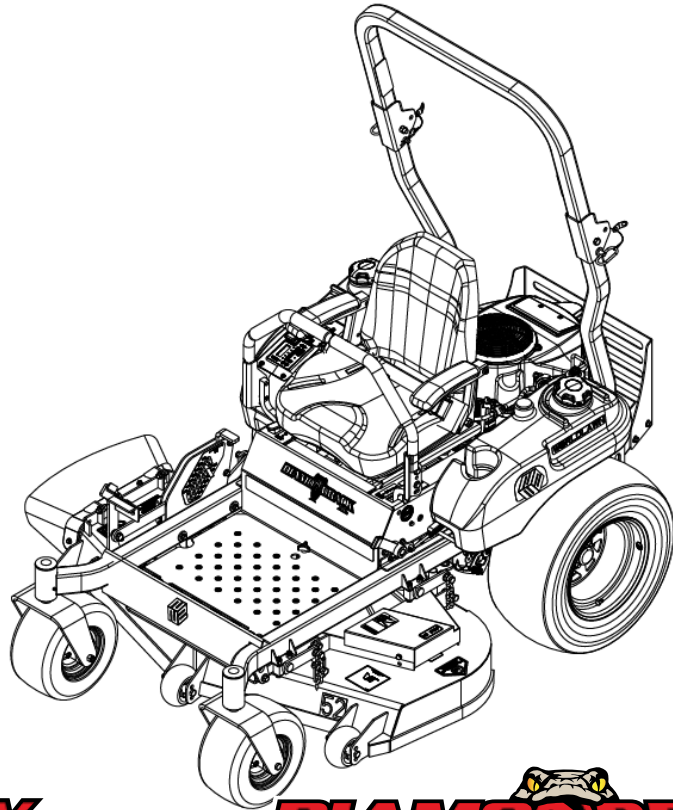

WORLDLAWN®

OPERATORS MANUAL



WYDB48FR691V32
WYDB48FR691V32CA
WYDB52FR691V32
WYDB52FR691V32CA
WYDB60FR730V32



WYDB52FS691V34
WYDB52FS691V34CA
WYDB52CT810V34
WYDB52CT810V34CA
WYDB60FS691V34
WYDB60FS691V34CA



WYDB52FX691V34
WYDB52FX691V34CA
WYDB60FX691V34
WYDB60FX691V34CA



WYDB52FX691V34E
WYDB52FX691V34ECA
WYDB60FX730V34E
WYDB60FX730V34ECA



WORLDLAWN POWER EQUIPMENT, INC.

WORLDLAWN.COM

401 COMMERCE STREET

BEATRICE, NE 68310

800-267-4255

FAX – 402-223-4103

Contents

AVAILABLE ACCESSORIES.....	9
SAFETY	10
SAFETY ALERT SYMBOL.....	10
TRAINING	10
PREPARATION.....	10
OPERATION.....	11
SLOPE OPERATION.....	13
USING THE ROLLOVER PROTECTION STRUCTURE	13
MAINTENANCE AND STORAGE.....	13
SAFETY AND INSTRUCTIONAL DECALS	15
SPECIFICATIONS	19
MODEL NUMBER	19
FUEL SYSTEM	19
ELECTRICAL SYSTEM	19
TRANSMISSION.....	19
CUTTING DECK.....	19
OPERATION.....	20
OPERATOR CONTROLS.....	20
STEERING AND MOTION CONTROL.....	20
SAFETY INTERLOCK	20
CHOKE CONTROL	20
THROTTLE CONTROL.....	20
PARK BRAKE LEVER.....	20
FUEL SHUT-OFF VALVE	21
IGNITION SWITCH.....	21
HOUR METER.....	21
DIGITAL CONSOLE INSTRUCTIONS.....	21
KEY CODE ENTERING	22
DRIVE WHEEL RELEASE VALVES.....	23
DECK LIFT PEDAL.....	24
TRANSPORT LOCK	24

BLADE ENGAGEMENT SWITCH	24
PRE-START	24
OPERATING INSTRUCTIONS	25
RAISE THE ROLLOVER PROTECTION STRUCTURE (ROPS)	25
STARTING THE ENGINE	25
BLADE ENGAGEMENT	25
DISENGAGING THE BLADES	25
STOPPING THE ENGINE.....	26
DRIVING THE MACHINE	26
DRIVING FORWARD	26
DRIVING IN REVERSE	26
ADJUSTING THE CUTTING HEIGHT	27
ADJUSTING THE ANTI-SCALP ROLLERS	27
TRANSPORTING	28
TRANSPORTING A UNIT	28
LOADING A UNIT.....	28
MAINTENANCE	29
RECOMMENDED MAINTENANCE SCHEDULE(S)	30
CHECK ENGINE OIL LEVEL	31
CHECK BATTERY CHARGE	31
RECOMMENDED JUMP STARTING PROCEDURE.....	32
CHECK MOWER BLADES	33
CHECK SAFETY INTERLOCK SYSTEM.....	33
CHECK ROPS.....	34
CHECK SEAT BELT.....	34
CHECK FOR LOOSE HARDWARE.....	34
SERVICE AIR CLEANER.....	34
CHANGE ENGINE OIL	34
CHANGE ENGINE OIL FILTER	34
CHECK HYDRAULIC OIL LEVEL	35
CHECK TIRE PRESSURES	35
CHECK CONDITION OF BELTS.....	35

LUBRICATE GREASE FITTINGS	35
CASTER WHEEL ROTATION	35
CHECK SPARK PLUGS	35
CHANGE HYDRAULIC SYSTEM FILTER AND FLUID.....	36
HYDRAULIC SYSTEM AIR PURGE	37
THREAD LOCKING ADHESIVES	37
COPPER-BASED ANTI-SEIZE.....	37
DIELECTRIC GREASE	38
CASTER PIVOT BEARINGS PRE-LOAD AND LUBRICATION.....	38
CHECK V-BELTS	38
ADJUSTMENTS.....	39
DECK LEVELING	39
PUMP DRIVE BELT TENSION	40
MOWER DECK DRIVE BELT TENSION	40
PARK BRAKE ADJUSTMENT.....	40
MOTION CONTROL LINKAGE ADJUSTMENT	41
NEUTRAL ADJUSTMENT.....	41
MOTION CONTROL DAMPER ADJUSTMENT.....	42
MOTION CONTROL NEUTRAL LOCK PIVOT ADJUSTMENT.....	42
MOTION CONTROL HANDLE ADJUSTMENT.....	42
CLEAN ALL DEBRIS FROM ENGINE AND EXHAUST SYSTEM AREA.	43
CLEAN DUST AND DIRT FROM CYLINDER HEAD FINS.....	43
CLEAN DEBRIS FROM MACHINE	43
CLEAN GRASS BUILD-UP UNDER DECK	43
TROUBLESHOOTING.....	44
STORAGE	46
WINTER STORAGE.....	46
DIAMONDBACK WIRING HARNESS.....	47
DIAMONDBACK XL WIRING HARNESS	48
EVAPORATIVE EMISSION CONTROL WARRANTY STATEMENT	51
LIMITED WARRANTY:	53

AVAILABLE ACCESSORIES

FITS MODELS: WYDB48FR691V32

WYDB48FR691V32CA

MULCH KIT:

461025 48" MULCH KIT

GRASS CATCHER ASSEMBLY:

5101305 48" GRASS CATCHER W/WEIGHTS
 632078 48" BLOWER
 632093 48" COLLECTION TUBE

FITS MODELS: WYDB52FR691V32

WYDB52FR691V32CA
 WYDB52CT801V34
 WYDB52CT801V34CA
 WYDB52FS691V34
 WYDB52FS691V34CA
 WYDB52FX691V34
 WYDB52FX691V34CA

MULCH KIT:

451004 52" MULCH KIT
 543436 BLADE, MULCH 18.0"

GRASS CATCHER ASSEMBLY:

5101305 52" GRASS CATCHER W/WEIGHTS
 632074 52" BLOWER
 542119 52" COLLECTION TUBE

FITS MODELS: WYDB60FS691V34

WYDB60FS691V34CA
 WYDB60FX691V34
 WYDB60FX691V34CA

MULCH KIT:

631027 60" MULCH KIT
 633340 BLADE, 20.5" MULCH

GRASS CATCHER ASSEMBLY

632086 60" GRASS CATCHER W/WEIGHTS
 632081 60" BLOWER
 542120 60" COLLECTION TUBE

SAFETY

SAFETY ALERT SYMBOL

This symbol means: **ATTENTION! BECOME ALERT! YOUR SAFETY IS INVOLVED!**



The safety alert symbol appears above information which alerts you to unsafe actions or situations and will be followed by the word **DANGER, WARNING, or CAUTION.**

 **DANGER:** White lettering/Red background.

Indicates an imminently hazardous situation which, if not avoided, will result in death or serious injury.

 **WARNING:** Black letters on orange background.

Indicates a potentially hazardous situation which, if not avoided, could result in death or serious injury.

 **CAUTION:** Black letters on yellow background.

Indicates a potentially hazardous situation which, if not avoided, may result in minor or moderate injury. It may also be used to alert against unsafe practices

TRAINING

- Read the instructions carefully. Become familiar with the safe operation of the equipment, operator controls, and safety signs.

- All operators need to be trained before operating this unit.
- Never let children or untrained people operate the equipment without proper instruction.
- Keep everyone, especially children and pets, away from the area of operation. Remember that the operator or user is responsible for accidents or hazards occurring to other people or their property.

PREPARATION

- Evaluate the terrain to determine what accessories and attachments are needed to properly and safely perform the job. Use only accessories and attachments approved by **WORLDLAWN**
- The use of personal protective equipment, such as (but not limited to) safety glasses, hearing protection, substantial footwear and long trousers is highly recommended.

 **CAUTION**

This machine produces sound levels in excess of 85 dBA at the operator's ear and can cause hearing loss through extended periods of exposure.

Wear hearing protection when operating this machine.

- Thoroughly inspect the area where the equipment is to be used and remove all stones, sticks, wires, bones, and other foreign objects which may damage the equipment or cause personal injury to operator or bystanders.
- Check that the operator's presence controls, safety switches, and shields are attached and functioning properly. Do Not operate unless they function properly.



DANGER

In certain conditions gasoline is extremely flammable and highly explosive.

A fire or explosion from gasoline can burn you, others and cause property damage.

- Refuel outdoors, on level ground while engine is cold.
- Never remove fuel cap or add fuel when engine is running or when engine is hot.
- Never fill the fuel tank so that gasoline level rises above the bottom of the filler neck to allow for gasoline expansion and prevent fuel spillage.
- If fuel is spilled, DO NOT attempt to start the engine. Move away from the area of the spill and avoid creating any source of ignition until fuel vapors have dissipated.
- Do not smoke while refueling and stay away from an open flame or where gasoline fumes may be ignited by spark.
- Do not operate without entire exhaust system in place and in proper working condition.
- Do not place any equipment that is leaking gasoline in an enclosed trailer.
- Be sure all fuel tanks and gasoline storage containers have proper caps installed to prevent spillage and minimize vapor escaping into the trailer.



DANGER

In certain conditions during fueling, static electricity can be released causing gasoline vapors to ignite.

A fire or explosion from gasoline can burn you, others, and cause property damage.

- Purchase and store gasoline only in an approved container
- Always place gasoline containers on the ground away from your vehicle while filling.

- Do not fill gasoline containers inside a vehicle or on a truck or trailer bed because interior carpets or plastic truck bed liners may insulate the container and slow the loss of any static charge.
- When practical, remove gas powered equipment from the truck or trailer and refuel the equipment with its wheels on the ground.
- If this is not possible, then refuel such equipment on a truck or trailer from a portable container, rather than from a gasoline dispenser nozzle.
- Before fueling, touch a metal surface to minimize the risk of static discharge.
- If a gasoline dispenser nozzle must be used, keep the nozzle in contact with rim of the fuel tank or container opening at all times until fueling is complete.



WARNING

Gasoline is harmful or fatal if swallowed. Long-term exposure to vapors and failure to use caution may cause serious injury or illness.

- **Avoid prolonged breathing of vapors.**
- **Keep face away from nozzle and gas tank/container opening.**
- **Keep away from eyes and skin.**
- **Never siphon by mouth.**

OPERATION

Although hazard control and accident prevention are partially dependent upon the design and configuration of the equipment, these factors are also dependent upon the awareness, concern and proper training of the personnel involved in the operation, transport, maintenance and the storage of the equipment. It is essential that all Operator Safety Mechanisms be connected and in operating condition prior to use for mowing.

 **WARNING**

Operating engine parts, especially the muffler, become extremely hot. Severe burns can occur on contact and debris, such as leaves, grass, brush, etc. can catch fire.

- Allow engine parts, especially the muffler, to cool before touching.
- Remove accumulated debris from muffler and engine area.

 **WARNING**

Engine exhaust contains carbon monoxide, which is an odorless deadly poison that can kill you.

Do Not run engine indoors or in a small confined area where dangerous carbon monoxide fumes can collect.

- Operate only in daylight or good artificial light, keeping away from holes and hidden hazards.
- Be sure all drives are in neutral and parking brake is engaged before starting engine.
- Never raise deck with blades running.
- Never operate the mower with damaged guards, shields, or covers. Always have safety shields, guards, switches and other devices in place and in proper working condition.
- Stop engine, wait for all moving parts to stop and engage parking brake:
 - Before refueling
 - Before dumping the grass catcher
 - Before making height adjustments
- Park machine on level ground. Stop engine, wait for all moving parts to stop, remove key and engage parking brake:
 - Before checking, cleaning or working on the mower.
 - After striking a foreign object or machine develops an abnormal vibration (inspect machine for

damage and repair before resuming operation)

- Before clearing blockages
- Before leaving the operator position
- Never mow with the discharge deflector raised, removed or altered unless there is a grass collection system or mulch kit in place and working properly.
- Do Not change the engine governor setting or overspeed the engine.

 **WARNING**

Hands, feet, hair, clothing, or accessories can become entangled in rotating parts. Contact with rotating parts can cause traumatic amputation or severe lacerations.

Do Not operate the machine without guards, shields, and safety devices in place and working properly.

Keep hands, feet, hair, jewelry, or clothing away from rotating parts. Keep hands and feet from under deck when PTO is engaged.

DO NOT operate the mower when people, especially children, or pets are in the area. Never carry passengers.

- Stop the blades, slow down, and use caution when transporting the mower to and from the area to be mowed or crossing surfaces other than grass.
- Do not operate the mower under the influence of alcohol or drugs.
- Be alert, slow down and use caution when making turns. Look behind and to the side before changing directions.
- Use extreme care when loading and unloading the machine into a trailer or truck.
- Be aware of the mower discharge path and direct discharge away from others.
- Use care when approaching blind corners, shrubs, trees, or other objects that may obscure vision.
- Always wear eye protection when operating machine.

SLOPE OPERATION

Use extreme caution when mowing and/or turning on slopes as loss of traction and/or tip-over could occur. The operator is responsible for the safe operation on slopes.



DANGER

Mowing on wet grass or steep slopes can cause sliding and loss of control.

- **Keep ROPS in raised & locked position and use seat belt.**
- **Mow across slopes, never up and down.**
- **Do Not mow slopes when grass is wet.**
- **Do Not mow near drop-offs or near water.**
- **Do Not mow slopes greater than 15 degrees.**
- **Reduce speed and use extreme caution on slopes.**
- **Avoid sudden turns or rapid speed changes.**
- Remove or mark obstacles such as rocks, tree limbs, etc. from the mowing area. Tall grass can hide obstacles.
- Be aware that operating on wet grass, across steep slopes or downhill may cause the mower to lose traction. Loss of traction to the drive wheels may result in sliding and a loss of braking and steering.
- Watch for ditches, holes, rocks, dips and rises that change the operating angle, as rough terrain could overturn the machine.
- Always avoid sudden starting or stopping on a slope. If tires lose traction, disengage the blades and proceed slowly off the slope.
- Use extreme care with grass catchers or attachments. These can change the stability of the machine and cause loss of control.

USING THE ROLLOVER PROTECTION STRUCTURE

There is no rollover protection when the roll bar is down. Wheels dropping over edges,

ditches, steep banks, or water can cause rollovers, which may result in serious injury, death or drowning.

- **Keep the roll bar in the raised and locked position and use seat belt.**
- **Lower the roll bar only when absolutely necessary.**
- **Do Not wear seat belt when the roll bar is down.**
- **Drive slowly and carefully.**
- **Raise the roll bar as soon as clearance permits.**
- **Check carefully for overhead clearances (i.e. branches, doorways, and electrical wires) before driving under any objects and Do Not contact them.**
- **In the event of a rollover, take the unit to an Authorized Service dealer to have the ROPS inspected.**

MAINTENANCE AND STORAGE

- Before any maintenance, disengage drives, lower implement, set parking brake, stop engine and remove key or disconnect spark plug wire. Wait for all moving parts to stop before adjusting, cleaning or repairing.
- Park machine on level ground. Never allow untrained personnel to service machine
- For engine maintenance, follow the engine manufacture's recommendations as stated in the engine manual.
- Keep engine, engine area, free from accumulation of grass, leaves, excessive grease, or oil and other debris. These materials can become combustible and may result in a fire.
- Maximum mowing results and safety can only be achieved if the mower is properly maintained and operated correctly.
- Check all bolts frequently to maintain proper tightness.
- Keep all guards, shields and safety devices in place and in safe working condition.
- All replacement parts must be the same as, or equivalent to, the parts supplied on original equipment.

- Use care when checking blades. Wrap the blade(s) or wear gloves, and use caution when servicing them. Only REPLACE damaged blades, NEVER straighten or weld them.
- Disconnect the battery cable from the negative battery post when the unit will be allowed to sit for more than 30 days without use.
- Store fuel in a container specifically designed for this purpose in a cool, dry place.
- Gasoline powered equipment or fuel containers should not be stored in a basement or any enclosed area where open pilot lights or heat appliances are present.
- Shut off fuel while storing or transporting. Do not store fuel near flames or drain indoors.
- Carefully release pressure from components with stored energy
- If possible, Do Not make adjustments with the engine running.
- If the machine strikes a foreign object, stop and inspect the machine. Repair, if necessary, before restarting.
- Check brake operation frequently. Adjust and service as required.
- Do not modify safety equipment. Check regularly to be sure it works properly. The machine must not be operated with defective or unmounted protective plate, protective cowlings, safety switches, or other protective devices.
- Regularly clean deck and underside of deck, avoid spraying engine and electrical components with water.



DANGER

Charging or jump starting the battery may produce explosive gasses. Battery gases can explode causing serious injury.

- **Keep sparks, flames, or cigarettes away from battery.**
- **Ventilate when charging or using battery in an enclosed space.**
- **Make sure venting path of battery is always open once battery is filled with acid**
- **Always shield eyes and face from battery.**



DANGER

Battery electrolyte contains sulfuric acid, which is poisonous and can cause severe burns. Swallowing electrolyte can be fatal or if it touches skin can cause severe burns.

- **Wear safety glasses to shield eyes, and rubber gloves to protect skin and clothing when handling electrolyte.**
- **Do Not swallow electrolyte.**
- **In the event of an accident, flush with water and seek medical attention immediately.**
- **Disconnect battery before making any repairs. Disconnect the negative terminal first and the positive last. Reconnect positive first and negative last.**



CAUTION

If the ignition is in the “ON” position there is potential for sparks and engagement of components. Sparks could cause an explosion or moving parts could engage causing personal injury.

Be sure ignition switch is in the “OFF” position before charging the battery.



WARNING

Removing standard, original equipment parts and accessories may alter the warranty, traction, and safety of the machine. Unauthorized changes to the engine, fuel or venting system, may violate EPA and CARB regulations.

New safety signs may be obtained from your authorized Worldlawn equipment dealer.

- Safety signs may be affixed by peeling off the backing to expose the adhesive surface. Apply only to a clean, dry surface. Smooth to remove any air bubbles.
- Familiarize yourself with the following safety signs and instructional labels. They are critical to the safe operation of your machine.

SAFETY AND INSTRUCTIONAL DECALS

- Keep all safety signs legible. Remove all grease, dirt and debris from safety signs and instructional labels.
- Replace all worn, damaged, or missing safety signs.
- When replacement components are installed, be sure that current safety signs are affixed to the replaced components.
- If an attachment or accessory has been installed, make sure current safety signs are visible.



8304



8303



363023



8008



8318

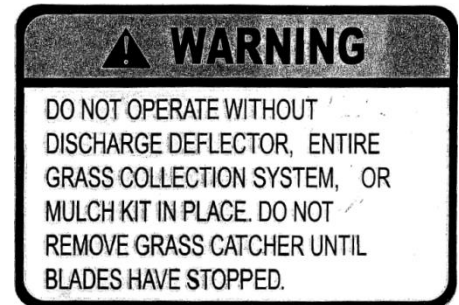

8307

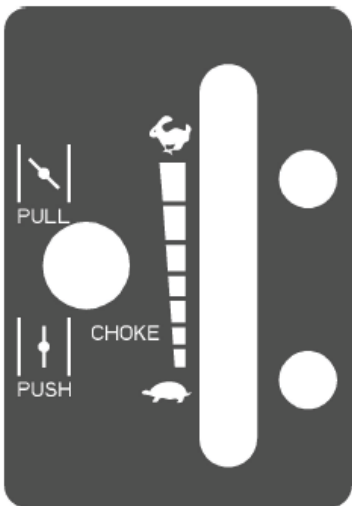

633124



8324



543433

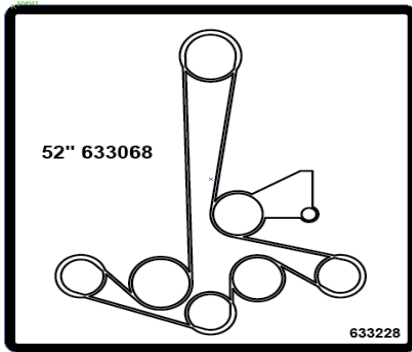

633228

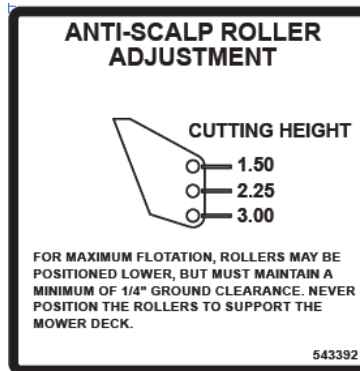

543392



543391



543397

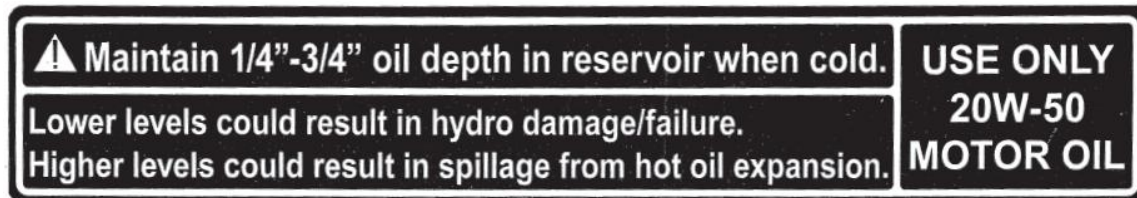

543396



543401

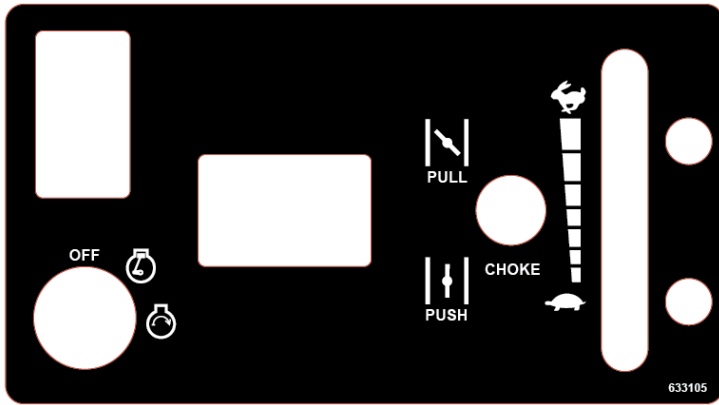

633105

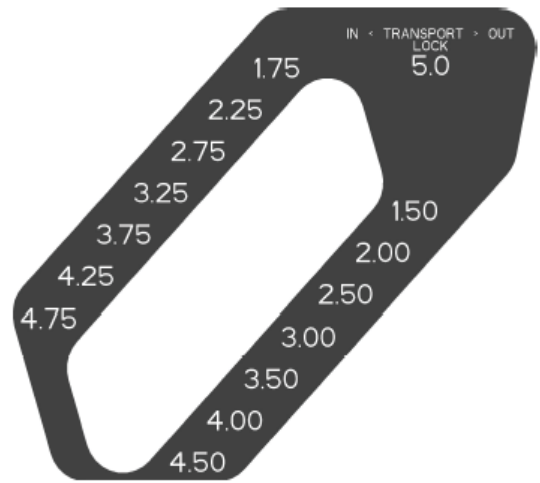

633106

SPECIFICATIONS

MODEL NUMBER

WYDB48FR691V32
 WYDB48FR691V32CA
 WYDB52FR691V332
 WYDB52FR691V32CA
 WYDB52FS691V34
 WYDB52FS691V34CA
 WYDB52CT810V34
 WYDB52CT810V34CA
 WYDB60FS691V34
 WYDB60FS691V34CA
 WYDB52FX691V34
 WYDB52FX691V34CA
 WYDB60FX691V34
 WYDB60FX691V34CA
 WYDB52FX691V34E
 WYDB52FX691V34ECA
 WYDB60FX730V34E
 WYDB60FX730V34ECA

WEIGHT & DIMENSIONS

	48"	52"	60"
Width Without Deck	47.8"	49.8"	49.8"
Width–Deflector Up	48.8"	52.8"	61"
Width–Deflector Down	59.9"	65.4"	73"
Length	77.4"	77.4"	77.4"
Height–ROPS Up	73"	73"	73"
Height–ROPS Down	53"	53"	53"
Wheelbase	50.3"	50.3"	50.3"
Curb Weight	941 lbs	951 lbs	961 lbs

ENGINE

Kawasaki FR691V; FS691V; FX691; FX730
 Briggs & Stratton CT810
 Specs: See your Engine Owner's Manual
 RPM: High Idle: 3600
 Low Idle: 1550

FUEL SYSTEM

- Capacity: 9.5 Gal
- Type of Fuel: Regular Unleaded Gasoline
87 Octane or higher
- Fuel Filter: In-line

ELECTRICAL SYSTEM

- Charging System: 12 Volt, 15 Amp @ 3600 RPM
- Battery Type: Group UI
- Battery Class: 280 CCA Minimum
- Battery Voltage: 12V DC
- Polarity: Neg. Ground
- Fuses:
 - DB XL/MAXX:
 - (1) 20A Main
 - (1) 20A Clutch
 - DB:
 - (1) 20A Main
 - (1) 15A Clutch

TRANSMISSION

- Two Hydro Gear® integrated transaxles
- Hydraulic Oil: 20w-50 Non- Synthetic
 - Speed:
 - ZT-3200
 - 0-9.0 mph Fwd
 - 0-4.8 mph Reverse
 - ZT-3400
 - 0-9.8 mph Fwd
 - 0-5.4 mph Reverse

CUTTING DECK

- Cutting Width: 48", 52" & 60"
- Discharge: Side
- Blade Size: 48": 16.25" (3 ea)
52": 18" (3 ea)
60": 20.5" (3 ea)
- Deck Drive: Electric Clutch
- Deck: 7 ga Welded Steel Floating Deck
- Deck Depth: 5.5"
- Cutting Height 1.5" to 4.75" Adjustment:
- Mulching Kit: Optional

TIRES

Front: 13 x 5.00-6 (48")
 13 x 6.50-6 Smooth (52" & 60")
 Pressure 12-14 psi (83-97 kPa)
 Rear: 23 x 9.5-12 (48")
 23 x 10.5-12 (52" & 60")
 Pressure 15 psi (103 kPa)

OPERATION

OPERATOR CONTROLS

STEERING AND MOTION CONTROL:

The motion control levers control the forward and reverse rotation of the respective tire. Speed is proportional to amount the levers are moved; moving the levers to the center (neutral) position brakes the movement of the machine.

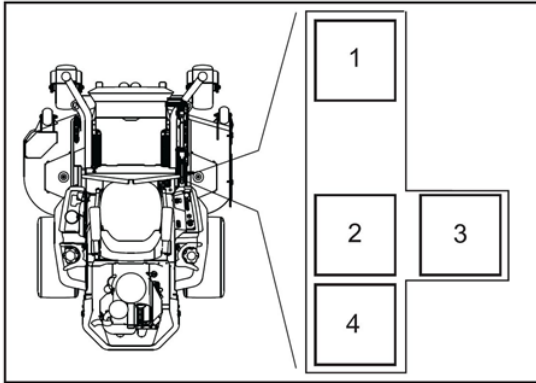

Motion Control View Pattern, RH Control shown

1. Forward
2. Neutral, Operate
3. Neutral, Lock
4. Reverse

SAFETY INTERLOCK

- Pictorial indicators appear for the PTO, park brake, drive levers, and operator presence on the respective decals.
- PTO must be disengaged, brake engaged, and motion control levers out (neutral lock) to start engine. (It is not necessary for the operator to be in the seat to start the engine.)
- Operator must be in seat when PTO is engaged, brake is disengaged, or motion control levers are moved in or engine will stop.
- Engine will stop if either the left, the right, or both levers are moved from neutral lock position while brake is engaged.

CHOKE CONTROL

The black pull knob located on the control console.

The choke is used to aid in starting a cold engine. Pulling the choke knob out will move the choke into the “on” position, pushing the choke knob back in will return the choke to the “off” position.

THROTTLE CONTROL

The red paddle located on the control console. The throttle is used to control engine speed. Moving the throttle lever forward will increase engine speed and moving the throttle lever to the rear will decrease engine speed. Moving the throttle forward into the detent is full throttle.

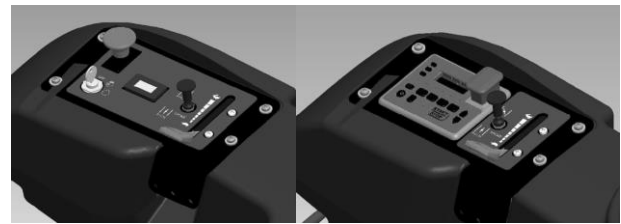

PARK BRAKE LEVER

- Located on left side of unit beside the LH motion control lever.
- To engage the brake, pull the lever rearward.
- To release, push the lever forward.
- The unit must be tied down and brake engaged when transporting.
- Park brake must be disengaged before moving.

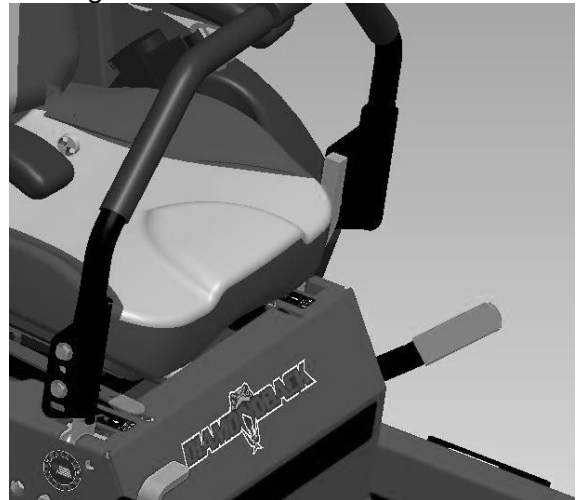

FUEL SHUT-OFF VALVE

Located behind the seat in front of the engine.

The fuel shut-off valve is used to shut off the fuel when the machine will not be used for a few days, during transport to and from the jobsite, and when parked inside a building.

Align valve handle with the fuel line to open. Rotate to horizontal position to close.

IGNITION SWITCH

Located on the control console. See below for complete Digital Console operating instructions.

The ignition switch is used to start and stop the engine. The switch has three positions “OFF”, “ON” and “START”. Insert key into switch and rotate clockwise to the “ON” position. Rotate clockwise to the next position to engage the starter (key must be held against spring pressure in this position). Allow the key to return to the “ON” position immediately after the engine starts. **NOTE:** To start the engine, the control levers must be in the neutral positions, park brake must be on, and blade switch must be off.

HOURLY METER

Located on the control console

The hour meter records the number of hours that the engine has run.

DIGITAL CONSOLE INSTRUCTIONS

LCD Information Center

D
I
S
P
L
A
Y
S

Engine hour meter – accumulative counting, non-resettable

Mower hour meter – accumulative counting, non-resettable

Job time – resettable

Time of day clock

Tachometer (RPM)

Volt meter – with low and high warning

Service Alerts – engine oil, hydraulic oil and air filter

NOTE – Your LCD may not display all icons as shown below

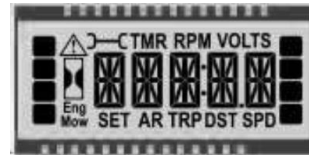

1. **Mower PTO Knob Pull** up to engage blades, push down to disengage.

2. **LCD Quick Toggle Buttons:** Depress and release to toggle between modes, depress and hold down for 6-9 seconds to reset/clear (Display shows “00000” when reset occurs)
NOTE: console must be powered up.

3. **LED Indicators:** Monitors equipment and operator conditions, alert the operator when necessary.

4. **Key Code Buttons:** Use to unlock and power up.

5. **Headlight Button:** Push and release to turn headlights on, repeat to turn headlights off.
NOTE: Your console may have a headlight button but not be equipped with headlights. Contact your dealer to purchase this accessory.

6. **Service alert Button:** Depress to access maintenance requirements and intervals. To reset depress and hold down for 6-9 seconds (Display shows “00000” when reset occurs)
NOTE: Only service alerts are resettable when console is powered up.

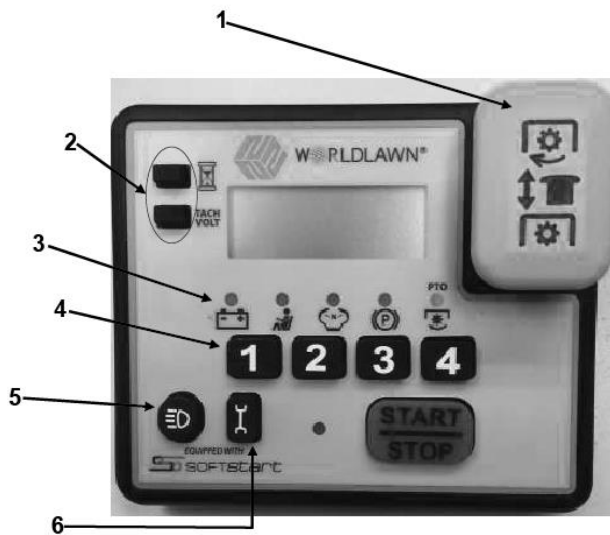

KEY CODE ENTERING

1. While positioned in the operator's seat enter your key code to unlock and power up the Console system (your key code is – 2412 but may be changed – see “Personalizing Your Key Code”. As you enter the key code it is displayed on the LCD always showing the last 5 digits *NOTE: If the incorrect code is entered the LCD flashes: “WRONG” “CODE”, re-enter correct code.*
2. After the key code is entered and console is unlocked the following conditions must be met in order to start the engine:
 - a) Operator must be in the seat
 - b) Parking brake must be on
 - c) Drive levers must be in their neutral position
 - d) PTO must be off

A red LED lights to indicate each of the above conditions that is not met. When all of the above conditions are met the “OK to Start” LED changes from red to green indicating the engine may be started.
3. Depress and hold down the Start/STOP button to start the engine, release when engine starts. *NOTE: you may feel there are two switches located under the Start/STOP button – both must be depressed to engage starter. Only one is required to shut the engine off.*

4. To shut off the engine simply push the Start/ Stop button once

PERSONALIZING YOUR KEY CODE

1. Engine must be stopped & console unlocked (correct key code entered) with PTO knob in.
2. Write down your new key code on a notepad (1 to 12 digits) for safe keeping, **forgetting code will require a dealership service call and charge to reset.**
3. Hold buttons 1 and 2 down for three seconds until the display shows “CHNGE” “CODE” followed by a blank screen.
4. Enter the new key code into the console. If more than 12 digits are entered the display will show: “FULL”. *NOTE: The display always shows last 5 digits entered.*
5. After entering the new code, pull the PTO knob out. If the new code is unusable within the console operating system then the display shows: “BAD” “CODE”. If this occurs push the PTO knob in and start step 1 again with a different code. *NOTE: If user does not enter a code and pulls the PTO knob the display will show: “EMPTY” “CODE”.*
6. If the new code is usable, the console prompts the user to re-enter the code again by displaying: “ENTER” “CODE” “AGAIN”. Enter the same unlock code again then push the PTO knob back in.
7. The console compares the two key codes entered in steps 4 and 5 to make sure they match. If they do the console saves the new unlock code and displays “SAVED” “CODE” before returning to the previous display mode. If they do not match the console displays “NO” “MATCH” and the user must begin again at step 1.

If no input is received for 10 seconds the console displays the message “TIME” “OUT” BEFORE RETURNING TO THE PREVIOUS DISPLAY MODE. The user must begin again at step 1.

TIME OF DAY CLOCK – SETTING

1. Engine must be stopped & console unlocked (correct key code entered) to set clock time.
2. Depress and release the hourglass button until the time of day clock is displayed.
3. Begin setting the time by depressing and holding down the hourglass button, after 3 seconds, the LCD displays: “SET”.
4. Release the hourglass button (the time will be flashing).
5. Use the number 1 & 4 buttons to change the new time down and up respectively. Single clicks change by 1 minute, hold down to change longer intervals. *NOTE: The time change rate accelerated the longer the button is held.*
6. Once the new time has been changed to the desired time, click the hourglass button once to save it.

SERVICE ALERTS

Your console is programmed to alert operator of upcoming service as follows:

Service Alert #1 CHG OIL – First time, break in oil changed at 20 hrs followed by normal reoccurring intervals of 100 hrs.

Service Alert #2 CHG HYD OIL – normal reoccurring intervals of 500 hrs.

Service Alert #3 SVC AIR FILTER – normal reoccurring intervals of 250 hrs.

A reminder will start flashing the alerts when they reach 5 hrs before service is required followed by the alert with the word “NOW” indicating service is due.

Resetting Alert: Enter operator code to power up console, depress and release the alert button (indicated with wrench) to toggle through the three alerts stopping at the specific alert to be reset. While in that alert depress and hold down the button for 6-9 seconds, display shows

“00000” when reset occurs. Reset can occur at any time within the service interval.

DRIVE WHEEL RELEASE VALVES

Drive wheel release valves are used to release the hydrostatic drive system to allow the machine to be moved by hand without the engine running. **Do Not tow machine**

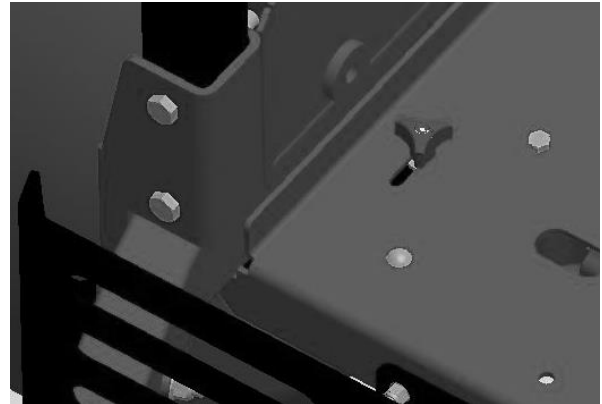

WARNING

Hands may become entangled in the rotating drive components below the engine deck, which could result in serious injury or death.

Stop engine, remove key, allow all the moving parts to stop before accessing the drive wheel release valves.



WARNING

The engine and hydraulic drive units can become very hot. Touching a hot engine or hydraulic drive units can cause severe burns.

Allow the engine and hydraulic drive units to cool completely before accessing the drive wheel release valves.

Zt-32/3400 Hydros

Located on inside face of hydros below the fan.

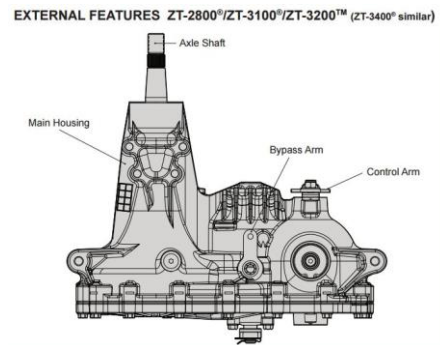

To release drive wheels, loosen knob, pull towards rear, tighten knob.

To re-engage drive, loosen knob, pull towards front, tighten knob.

DECK LIFT PEDAL

Located at the right front corner of the floor pan.

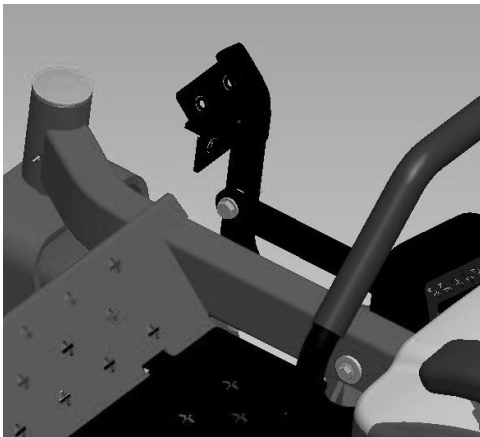

Push the pedal forward with your foot to raise the cutting deck. Allow the pedal to move rearward to lower the cutting deck to the cut height that has been set.

TRANSPORT LOCK

Located at rear of height of cut plates on RH side of floor pan. Transport pawl engages side link when deck is raised to up-stop, preventing deck from being lowered. To lower deck, apply pressure to foot pedal, pull rearward on pawl

handle, and reduce pressure on foot pedal until deck lowers to pre-selected cut height.

BLADE ENGAGEMENT SWITCH

Located on console.

Switch must be pulled out (up) to engage the blades. Switch is pushed in to disengage the blades.

PRE-START

Fill fuel tank on level ground. For best results use only clean, fresh regular grade unleaded gasoline with an octane rating of 87 or higher.

IMPORTANT: Never use methanol, gasoline containing methanol, gasohol containing more than 10% ethanol, premium gasoline, or white gas because the fuel system could be damaged.

Do Not add oil to gasoline

Do Not over fill fuel tank. Fill the fuel tank to the bottom of the filler neck. The empty space in the tank allows gasoline to expand. Overfilling may result in fuel leakage or damage to the engine or emission system.

Make sure you understand the controls, their locations, their functions, and their safety requirements.

Refer to the Maintenance section and perform all the necessary inspection and maintenance steps.

OPERATING INSTRUCTIONS

- Perform daily maintenance
- Check fuel level
- Open Fuel valve
- Adjust seat

RAISE THE ROLLOVER PROTECTION STRUCTURE (ROPS)

IMPORTANT: The roll bar is an integral and effective safety device. Keep the roll bar in the raised and locked position when operating the mower. Lower the roll bar temporarily only when absolutely necessary.

STARTING THE ENGINE

1. Move both control levers to the neutral position.
2. Pull the parking brake lever rearward to engage the parking brake.
3. Push in (down) on the PTO switch to the “disengage” position.
4. Place the throttle midway between the “SLOW” and “FAST” positions.
5. On a cold engine, pull the choke lever up into the “ON” position.

On a warm engine, leave the choke in the “OFF” position.

6. Turn ignition switch to the “START” position. Release the switch as soon as the engine starts.

IMPORTANT: Do Not crank the engine continuously for more than ten seconds at a time. If the engine does not start, allow a 60 second cool-down period between starting attempts. Failure to follow these guidelines can burn out the starter motor.

7. If the choke is in the “ON” position, gradually return choke to the “OFF” position as the engine warms up.

BLADE ENGAGEMENT



DANGER

The rotating blades under the mower deck are dangerous. Blade contact can cause serious injury or death.

Do Not put hands or feet under the mower or mower deck when the blades are engaged.



DANGER

An uncovered discharge opening will allow objects to be thrown in an operator’s or bystander’s direction. Also, contact with the blade could occur. Thrown objects or blade contact can cause serious injury or death.

Never operate the mower with the discharge deflector raised, removed, or altered unless there is a grass collection system or mulch kit in place and working properly.

The PTO switch engages the cutting blades. Be sure all persons are clear of mower deck and discharge area before engaging the PTO.

1. Set throttle to an intermediate position between slow and fast.
2. Pull up on the blade control switch (PTO). The clutch should engage and the mower blades begin rotating.
3. If engage PTO stalls engine, try partially choking the engine. When PTO is engaged return choke to OPEN.
4. Place the throttle in the “FAST” position to begin mowing.
5. Disengage park brake before operating machine.

DISENGAGING THE BLADES

1. Set the throttle midway between the “SLOW” and “FAST” positions.
2. Push down on the PTO switch to disengage the blades.

STOPPING THE ENGINE

1. Bring the unit to a full stop.
2. Move the motion control levers to the neutral position; move the control levers out to the neutral lock position.
3. Engage the parking brake.
4. Push down on the PTO switch to disengage the blades.
5. Place the throttle midway between the “SLOW” and “FAST” positions.
6. Turn the ignition switch to the “OFF” position to stop the engine.
7. Remove the key to prevent children or other unauthorized persons from starting engine
8. Shut off fuel.

DRIVING THE MACHINE TRAINING

Due to unique steering capabilities, zero turn mowers are far more maneuverable than typical riding mowers.

This section should be reviewed in its entirety prior to attempting to move the mower under its own power. When first operating the mower or until becoming comfortable with controls, use a reduced throttle speed and reduced ground speed. DO NOT move control levers to the furthest forward or reverse positions during initial operation.

First time users should become familiar with the mower’s movement on a hard surface, such as concrete or blacktop PRIOR to attempting to operate on turf. Until the operator becomes comfortable with the mower controls and zero turning capability, overly aggressive maneuvers may damage turf.



CAUTION

Erratic movement of the control levers may cause the Operator to lose control of the machine, which may cause damage to the machine or injury.

- **Use slow and steady movement of the control levers.**
- **Use caution when making turns.**
- **Slow the machine down before making sharp turns.**

IMPORTANT: To begin movement (forward or backward) the operator must be in the seat, the brake lever must be disengaged (pushed down) before the motion control levers can be moved in or the engine will stop.

When the motion control levers are positioned fully outward (apart) in the T-slot, the drive system is in the neutral lock position (Figure 13).

When the motion control levers are moved directly inward (together) the drive system is in the neutral operate position.

DRIVING FORWARD

1. Release the parking brake.
2. Move motion control levers to neutral operate position.
3. To move forward in a straight line, move both levers forward with equal pressure.

To turn left or right, pull the motion control lever back toward neutral in the desired turn direction.

The machine will move faster the farther the motion control levers are moved from the neutral position.

4. To stop, position both motion control levers in the neutral operate position.

DRIVING IN REVERSE

1. Move the motion control levers to the neutral operate position.
2. To move rearward in a straight line, slowly move both levers rearward with equal pressure.

To turn left or right, release pressure on the motion control lever toward the desired turn direction.

3. To stop, position both motion control levers in the neutral operate position.

ADJUSTING THE CUTTING HEIGHT

The cutting height of the mower deck is adjusted from 1.5 to 4.75 inches (3.8 cm to 12.0 cm) in 1/4 inch (6.4 cm) increments.

1. Stop the machine and move the motion control levers to the neutral position.
2. Disengage the PTO.
3. Raise and lock the deck to the 5 inch (12.7 cm) transport position.

The deck is raised by pushing the foot operated deck lift pedal forward. The pedal is located at the front right corner of the floor pan.

Note: When changing the cutting height positions, always come to a complete stop and disengage the PTO.

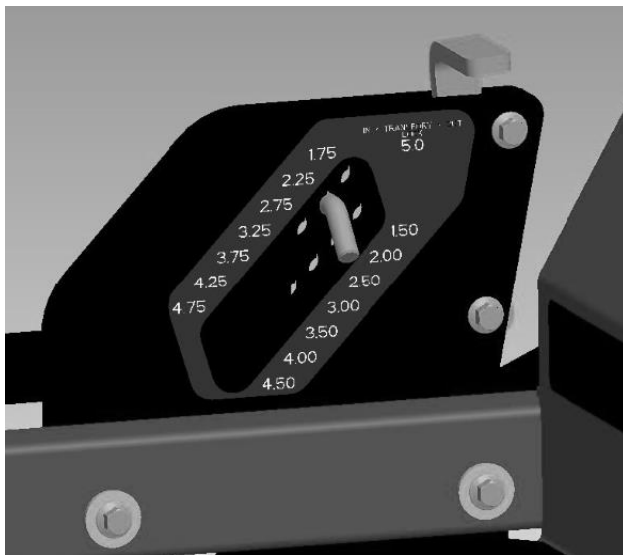

4. Insert the height adjustment pin into the hole corresponding to the desired cutting height.
See the decal on the side of the deck lift plate for cut heights.
5. Push the deck lift pedal, hold back the transport pawl handle and allow the deck to lower to the cutting height.

ADJUSTING THE ANTI-SCALP ROLLERS

It is recommended to change the anti-scalp roller position, when the height of cut has changed.

1. Stop the machine and move the motion control levers outward to the neutral locked position.
2. Disengage the PTO.
3. Engage the park brake.
4. Stop the engine, remove the key and wait for all moving parts to stop.
5. Place the rollers in one of the positions shown. Rollers will maintain 3/4 inch (19 mm) clearance to the ground to minimize gouging and roller wear or damage.

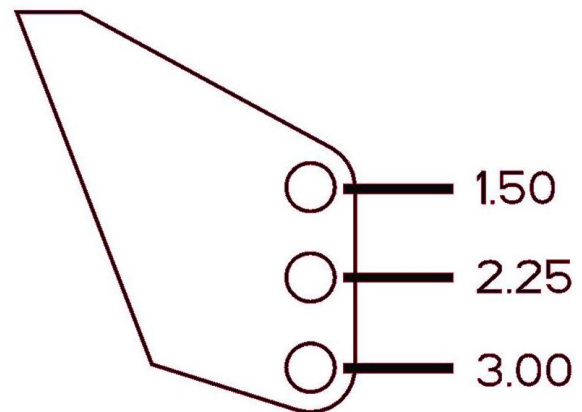

For cutting heights above 3.5 inches (90 mm) use the bottom hole. The rollers will still be effective against scalping.

For Maximum Deck flotation, place the rollers one hole position lower. Rollers should maintain 1/4 (6.4 mm) clearance to the ground. **Do Not** adjust the rollers to support the deck.

Note: The foot operated deck lift assist lever can be used to momentarily lift the deck to clear objects. Be sure that PTO is disengaged.

TRANSPORTING

TRANSPORTING A UNIT

Use a heavy-duty trailer or truck to transport the machine. Lock brake and block wheels.

Securely fasten the machine to the trailer or truck with straps, chains, cable, or ropes. Be sure that the trailer or truck has all necessary lighting and marking as required by law.

Secure a trailer with a safety chain.



CAUTION

This unit does not have proper turn signals, lights, reflective markings, or a slow moving vehicle emblem. Driving on a street or roadway without such equipment is dangerous and can lead to accidents causing personal injury. Driving on a street or roadway without such equipment may also be a violation of State laws and the operator may be subject to traffic tickets and/or fines.

Do Not drive a unit on a public street or roadway.



WARNING

Loading a unit on a trailer or truck increases the possibility of backward tip-over.

Backward tip-over could cause serious injury or death.

- **Use extreme caution when operating a unit on a ramp**
- **Use only a single, full width ramp; Do Not use individual ramps for each side of the unit.**
- **If individual ramps must be used, use enough ramps to create an unbroken ramp surface wider than the unit.**
- **Do Not exceed a 15 degree angle between ramp and ground or between ramp and trailer or truck.**
- **When possible, back machine onto transport vehicle to avoid a rearward tip-over.**

- **Avoid sudden acceleration while driving unit forward up a ramp to avoid tipping backward.**
- **Avoid sudden deceleration while backing unit down a ramp to avoid tipping backward.**

LOADING A UNIT

Use extreme caution when loading units on trailers or trucks. Backing unit onto trailer or truck is recommended practice to avoid rearward tip-over. However, condition such as ramp angle and surface slickness can prevent adequate drive wheel traction to accomplish this. One full width ramp that is wide enough to extend beyond the rear tires is recommended instead of individual ramps for each side of the unit. The lower rear section of the tractor frame extends back between the rear wheels and serves as a stop for tipping backward. Having a full width ramp provides a surface for the frame members to contact if the unit starts to tip backward. If it is not possible to use one full width ramp, use enough individual ramps to simulate a full width continuous ramp.

Ramp should be long enough so that the angles between the ramp and the ground and the ramp and the trailer or truck do not exceed 15 degrees. A steeper angle may cause mower deck components to get caught as the unit moves from ramp to trailer or truck. Steeper angles may also cause the unit to tip backward. If loading on or near a slope, position the trailer or truck so it is on the down side of the slope and the ramp extends up the slope. This will minimize the ramp angle. The trailer or truck should be as level as possible.

IMPORTANT: Do Not attempt to turn the unit while on the ramp, you may lose control and drive off the side.

Avoid sudden acceleration when driving up a ramp and sudden deceleration when backing down a ramp. Both maneuvers can cause the unit to tip backward.

MAINTENANCE

Note: The *left* and *right* side of the machine is determined by sitting in the normal operator's position.

 **WARNING**

Remove the key from the ignition switch, engage parking brake, and pull the wire(s) off the spark plug(s) before you do any maintenance. Also push the wire(s) aside so accidental contact with the spark plug does not occur.

While maintenance or adjustments are being made, someone could start the engine. Accidental starting of the engine could seriously injure you or other bystanders.

 **WARNING**

Allow the engine to cool completely before service or making repairs around the engine area.

The engine can become very hot. Touching a hot engine can cause severe burns.

RECOMMENDED MAINTENANCE SCHEDULE(S)

Maintenance Service Interval	Maintenance Procedure
Before each use or daily	<ul style="list-style-type: none"> • Check the engine oil level • Check the mower blades • Check the safety interlock system • Check seat belt • Check for loose hardware • Check for belt obstructions • Check for fuel and oil leakage • Clean the engine and exhaust system area • Clean the grass and debris build-up from the machine and cutting deck, including under the deck
After the first 8 hours	<ul style="list-style-type: none"> • Change the engine oil
After the first 100 hours	<ul style="list-style-type: none"> • Torque the wheel lug nuts • Change the hydraulic filter and fluid (20W50 engine oil)
Every 40 hours	<ul style="list-style-type: none"> • Check the hydraulic oil level • Check the condition of the belts • Check the tire pressures • Lubricate the caster wheel bearings • Lubricate strut arms
Every 100 hours	<ul style="list-style-type: none"> • Clean dust and dirt from cylinder and cylinder head fins • Change engine oil • Check V-Belts • Clean and regap spark plugs
Every 200 hours	<ul style="list-style-type: none"> • Check front caster wheel rotation • Change engine oil filter
Every 250 hours	<ul style="list-style-type: none"> • Replace the primary air cleaner • Check secondary air cleaner – replace if dirty. See the Engine manual for additional information
Every 400 hours	<ul style="list-style-type: none"> • Change hydro oil and filter
Every 500 hours	<ul style="list-style-type: none"> • Check the wheel hub torque • Torque the wheel lug nuts • Replace the secondary air cleaner. See the Engine manual for additional information.
Monthly	<ul style="list-style-type: none"> • Check the battery charge
Yearly	<ul style="list-style-type: none"> • Grease the front caster pivots

CHECK ENGINE OIL LEVEL

Check the engine oil daily before starting the engine otherwise shortage of the engine oil may cause serious damage to the engine such as seizure.

- Place the engine on a level surface. Clean area around the oil gauge before removing it.
- Remove the oil gauge and wipe it with a clean cloth.
- Reinsert the oil gauge to check the oil level. The level should be between “ADD” and “FULL” marks. Do not overfill.
- Install and tighten the oil gauge



CAUTION

Do not fill above the “FULL” mark. Excess oil will cause a smoking condition, and may cause the engine to overheat.

CHECK BATTERY CHARGE

Service Interval: Monthly

IMPORTANT INFORMATION

Do not attempt to open or remove caps or covers. Adding or checking level of electrolyte is not necessary.
Always use two wrenches for the terminal screws.



WARNING

Do not short battery terminals by allowing a wrench or any other object to contact both terminals at the same time. Before connecting battery, remove metal bracelets, wristwatch bands, rings, etc.

Positive terminal must be connected first to prevent sparks from accidental grounding.



WARNING

CALIFORNIA PROPOSITION 65

BATTERY POSTS, TERMINALS, AND RELATED ACCESSORIES CONTAIN LEAD AND LEAD COMPOUNDS, CHEMICALS KNOWN TO THE STATE OF CALIFORNIA TO CAUSE CANCER AND REPRODUCTIVE HARM. WASH HANDS AFTER HANDLING.

Allowing batteries to stand for an extended period of time without recharging them will result in reduced performance and service life. To preserve optimum battery performance and life, recharge batteries in storage when the open circuit voltage drops to 12.4 volts.

NOTE: To prevent damage due to freezing, battery should be fully charged before putting away for winter storage.

Check the voltage of the battery with a digital voltmeter. Locate the voltage reading of the battery in the table and charge the battery for the recommended time interval to bring the charge up to a full charge of 12.6 volts or greater.

IMPORTANT: Make sure the negative battery cable is disconnected and the battery charger used for charging the battery has an output of 16 volts and 7 amps or less to avoid damaging the battery (see chart for recommended charger settings).

Voltage Reading	Percent Charge	Maximum Charger Settings	Charging Interval
12.6 or greater	100%	16 volts/7 amps	No Charging Required
12.4 – 12.6	75%-100%	16 volts/7 amps	30 Minutes
12.2 – 12.4	50- 75%	16 volts/7 amps	1 Hour
12.0 – 12.2	25 – 50%	14.4 volts/4 amps	2 Hours
11.7 – 12.0	0 – 25%	14.4 volts/4 amps	3 Hours
11.7 or less	0%	14.4 volts/2 amps	6 Hours or More

RECOMMENDED JUMP STARTING PROCEDURE

Service Interval: As required

1. Check the weak battery for terminal corrosion (white, green, or blue “snow”), it must be cleaned off prior to jump starting, Clean and tighten connections as necessary

CAUTION

Corrosion or loose connections can cause unwanted electrical voltage spikes at anytime during the jump starting procedure.

Do Not attempt to jump start with loose or corroded battery terminals or damage to the engine may occur.

DANGER

Jump starting a weak battery that is cracked, frozen, has low electrolyte level, or an open/shorted battery cell, can cause an explosion resulting in serious personal injury.

Do Not jump start a weak battery if these conditions exist.

2. Make sure the booster is a good and fully charged lead acid battery at 12.6 volts or greater. Use properly sized jumper cables (4 to 6 AWG) with short lengths to reduce voltage drop between systems. Make sure the cables are color coded or labeled for the correct polarity.

CAUTION

Connecting the jumper cables incorrectly (wrong polarity) can immediately damage the electrical system.

Be certain of battery terminal polarity and jumper cable polarity when hooking up batteries.

NOTE: The following instructions are adapted from the SAE J1494 Rev. Dec. 2001 – Battery Booster Cables – Surface Vehicle Recommended Practice (SAE – Society of Automotive Engineers).

WARNING

Batteries contain acid and produce explosive gasses.

- **Shield the eyes and face from the batteries at all times.**
- **Do Not lean over the batteries.**

NOTE: Be sure the vent caps are tight and level. Place a damp cloth, if available, over any vent caps on both batteries. Be sure the vehicles do not touch and that both electrical systems are off and at the same rated system voltage. These instructions are for negative ground systems only.

3. Connect the positive (+) cable to the positive (+) terminal of the discharged battery.
4. Connect the other end of the positive cable to the positive terminal of the booster battery.
5. Connect the black negative (-) cable to the other terminal (negative) of the booster battery.
6. **MAKE THE FINAL CONNECTION ON THE ENGINE BLOCK OF THE STALLED VEHICLE (NOT TO THE NEGATIVE POST) AWAY FROM THE BATTERY. STAND BACK.**
7. Start the vehicle and remove the cables in the reverse order of connection (the engine block (black) connection is the first to disconnect).

CHECK MOWER BLADES

Service Interval: Before each use or daily

Stop engine, wait for all moving parts to stop, and remove key. Engage parking brake.

1. Lift deck and secure in raised position as stated in the **Clean Grass Build-Up Under Deck** section.
2. Inspect blades and sharpen or replace as required.
3. Reinstall the blades (if they were removed) in the following order:
 - A. Install (3) spacers, blade, spring washers and bolt.
 - B. Install the bushing and blade onto spindle.
 - C. Apply lubricant to threads of blade bolt as needed to prevent seizing. Copper-based anti-seize preferable. Grease acceptable substitute. Install blade bolt finger tight then torque the blade bolts to 50-60 ft-lb (68-81 N-m).



WARNING

Incorrect installation of the blade or components used to retain the blade can be dangerous. Failure to use all original components and assembled as shown could allow a blade or blade component to be thrown out from under the deck resulting in serious personal injury or death.

Always use original equipment, i.e. blades, blade bushings, and blade bolts as shown.



WARNING



Blades are sharp. Protect your hands with gloves and/or wrap blades with a heavy cloth when handling.

CHECK SAFETY INTERLOCK SYSTEM

Service Interval: Before each use or daily



CAUTION

It is essential that operator safety mechanisms be connected and in proper operating condition prior to use.

- **Do not tamper with the interlock switch.**
- **Check the operation of the interlock switches daily and replace any damaged switches before operating the machine.**

• **Note:** To prevent engine cut-outs on rough terrain the seat kill switch has a 1/2 second delay.

1. Check starting circuit. Starter **should** crank with parking brake **engaged**, PTO **disengaged** and motion control levers moved out in the **neutral lock** position. The operator does not need to be in the seat to start the engine.

Try to start with **operator in seat**, parking brake **disengaged**, PTO **disengaged** and motion control levers in the **neutral lock** position – starter **must not crank**.

Try to start with **operator in seat**, parking brake **engaged**, PTO **engaged** and motion control levers in the **neutral lock** position – starter **must not crank**.

Try to start with **operator in seat**, parking brake **engaged**, PTO **disengaged**, and the **left motion control lever in**, starter **must not crank**, repeat again with the **right lever in**, then with **both levers in** – starter **must not crank**.

2. Check the kill circuits. Run engine at one-third throttle, **disengage** parking brake and **raise off** of seat (but do not get off of machine) engine **must initiate shutdown** after approximately 1/2 second has elapsed (seat has time delay kill switch to prevent cut-outs on rough terrain).

Run engine at one-third throttle, **engage PTO** and **raise off** of seat (but do not get off of machine) engine **must initiate shutdown** after

one second has elapsed if the handles are in. The delay will be 1/2 second if the handles are out.

Run engine at one-third throttle, with brake disengaged, move levers in and raise off seat (but do not get off of machine) engine **must initiate shutdown** after 1/2 second has elapsed.

Again, run engine at one-third throttle, brake **engaged**, and move **left motion control lever in** – engine **must initiate shutdown** after 1/2 second has elapsed.

Repeat again moving the **right lever in**, then moving **both levers in** – engine **must initiate shutdown** after 1/2 second has elapsed whether operator is **on seat or not**.

Note: If machine does not pass any of these tests, do no operate. Contact your authorized **Worldlawn service dealer**.

Important: It is essential that operator safety mechanisms be connected and in proper operating condition prior to use for mowing.

CHECK ROPS

Service Interval: Before each use or daily

Check that mounting hardware is tight. Make sure pins are fully engaged and secured with cotter hairpins.

CHECK SEAT BELT

Service interval: Before each use or daily

Visually inspect seat belt for wear, cuts, and proper operation of retractor and buckle. Replace before operating if damaged.

CHECK FOR LOOSE HARDWARE

Service Interval: Before each use or daily

1. Stop engine, wait for all moving parts to stop and remove key. Engage parking brake.
2. Visually inspect machine for any loose hardware or any other possible problem.

Tighten hardware or correct problem before operating.

SERVICE AIR CLEANER

Service Interval: 250 Hours

1. Stop engine, wait for all moving parts to stop and remove key. Engage parking brake.
2. See the Engine Owner's Manual for maintenance instructions.

CHANGE ENGINE OIL

Service Interval: 100 hours

NOTE: Change oil and filter after first eight (8) hours of operation.

1. Stop engine, wait for all moving parts to stop and remove key. Engage parking brake.
2. Drain oil while engine is warm.
3. The oil drain valve is located on the RH side of the engine. Place the pan under the machine to catch the oil. Loosen the oil drain valve and allow the oil to drain. Tighten the oil drain valve .
4. Clean around oil fill cap and remove cap. Fill to specified capacity and replace cap.
5. Use oil recommended in the Engine Owner's Manual. DO NOT overfill. Wipe up any spilled oil from engine deck mounting surfaces.
6. Start the engine and check for leaks. Stop engine and recheck oil level.

CHANGE ENGINE OIL FILTER

Service Interval: 200 hours

1. Follow steps 1 through 3 above for engine oil change
2. Replace the oil filter per the engine Owner's Manual. Clean around the oil filter and carefully remove the filter by unscrewing it. Make sure no oil drains onto the belt drive or clutch through the holes in the engine deck. Before the new filter is installed, apply a thin coating of oil on the surface of the rubber seal. Turn filter clockwise until rubber seal contacts the filter

adapter, then tighten filter and additional 2/3 to 3/4 turn.

- Follow steps 4 through 6 above to refill engine oil.

CHECK HYDRAULIC OIL LEVEL

Service Interval: Every 40 hours

- Stop engine, wait for all moving parts to stop and remove key. Engage parking brake.
- Clean area around hydraulic reservoir cap and remove cap. Oil level should be between 1/4" – 3/4" when cold. Lower levels can result in hydro damage/failure. Higher levels can result in spillage from hot oil expansion. If necessary, add SAE 20W50 motor oil. Replace hydraulic reservoir cap and tighten until snug. Do not over-tighten.

CHECK TIRE PRESSURES

Service Interval: Every 40 hours

- Stop engine, wait for all moving parts to stop and remove key. Engage parking brake.
- Check tire pressure.
- Inflate drive tires to 12-14 psi (83-97 kPa).
- Inflate caster tires to 15 psi.

CHECK CONDITION OF BELTS

Service Interval: Every 40 hours

- Stop engine, wait for all moving parts to stop and remove key. Engage parking brake.
- Look on the top side of the cutting deck to check the mower blade drive belt condition.
- Look under the engine deck to check the pump drive belt condition.
- Check all idler arms to be sure they pivot freely.

LUBRICATE GREASE FITTINGS

Note: See chart for service intervals.

- Stop engine, wait for all moving parts to stop and remove key. Engage parking brake.
- Lubricate fittings with NGLI #2 multi-purpose grease.

CASTER WHEEL ROTATION

Service Interval: Every 200 hours

Removal and Installation

Remove nut and caster bolt. Pull the wheel out of the fork. Install in reverse order. Tighten caster bolt. Torque to 45 ft-lbs (61Nm), then back nut off 1/2 turn.

NOTE: Tire should rotate freely but axle spacers should not.

If wheels do not rotate freely take the unit to the dealer for service.

Lubrication Chart

FITTING LOCATIONS	INITIAL PUMPS	NUMBER OF PLACES	SERVICE INTERVAL
1. Front Caster Wheel Hubs	1	2	Weekly
2. Front Caster Pivots	0	2	Yearly

CHECK SPARK PLUGS

Service Interval: Every 100 Hours

Remove spark plugs, check condition and reset gaps, or replace with new plugs. See Engine Owner's Manual.

CHANGE HYDRAULIC SYSTEM FILTER AND FLUID

Service Interval: Every 400 Hours

This transaxle is designed with a serviceable filter. To ensure constant fluid quality levels and longer life, an initial oil and filter change at 100 hours is recommended. Subsequent changes are recommended at 400 hour intervals minimum, or yearly, whichever comes first.

The following procedure can be performed with the transaxle installed in the vehicle, and the vehicle on level ground. Apply the bypass valve and lock the vehicle parking brake.

1. Remove the three 1/4" filter guard screws and filter guard. Clean any loose debris from around the perimeter of the filter. See figure below.
2. Place an oil drain pan (12" or more diameter and 8 qt. capacity is optimal) beneath the oil filter. Remove the oil filter from the transaxle.
3. After the oil has drained, wipe the filter base surface off and apply a film of new oil to the gasket of the new replacement filter (Hydro-Gear part number 52114).
4. Install the new filter by hand, turn 3/4 to one full turn after the filter gasket contacts the filter base surface.
5. Re-install the filter guard with three 1/4" screws. Torque screws to 65 in/lbs (7.3 Nm) each.
6. Repeat steps 1-5 on the opposite side transaxle drive.
7. Drain old oil filters of all free flowing oil prior to disposal. Place used oil in appropriate containers and deliver to an approved recycling collection facility.
8. Remove the top port plug from the left side and right side transaxles prior to filling with oil. This will allow the transaxles to vent during oil fill.
9. Remove the cap from the transaxle's expansion tank located on the vehicle frame.
10. Fill with 20W50 motor oil until oil just appears at the bottom of each transaxle's top port (approximately 2 qts. Per transaxle, 4 qts. Total). Install the top port plug into each transaxle as the oil level reaches this port. See figure below.
11. Install and torque the top port plugs to 180 in/lbs (20.3 Nm).
12. Continue to fill the transaxles through the expansion tank until the "Full Cold" line is reached on the Hydro-Gear expansion tank.
13. Re-install the expansion tank cap by hand. Be careful to not over-tighten.
14. Proceed to the purge procedure.

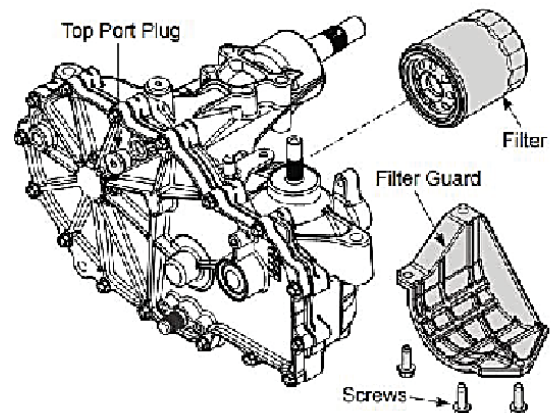
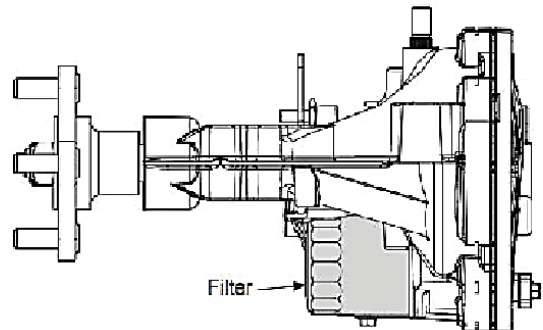



CAUTION

Raising the mower for service or maintenance relying solely on mechanical or hydraulic jacks could be dangerous. The mechanical or hydraulic jacks may not be enough support or may malfunction allowing the unit to fall, which could cause injury.

Do not rely solely on mechanical or hydraulic jacks for support. Use adequate jack stands or equivalent support.

HYDRAULIC SYSTEM AIR PURGE

Service Interval: As Required

Due to the effects air has on efficiency in hydrostatic drive applications, it is critical that air is removed or purged from the system.

These purge procedures must be performed anytime a hydrostatic system has been opened for maintenance or repair, or if any additional oil has been added to the system.

Air creates inefficiency because it has compression and expansion rates that are higher than that of oil.

Air trapped in the oil may cause the following symptoms:

- Noisy operation.
- Lack of power or drive after short-term operation.
- High operation temperature and excessive expansion of oil.

Before starting make sure the reservoir is at the proper oil level. If it is not, fill to the vehicle manufacturer's specifications.

The following procedures should be performed with the vehicle drive wheels off the ground,

then repeated under normal operating conditions.



WARNING

POTENTIAL FOR SERIOUS INJURY

Certain procedures required the vehicle engine to be operated and the vehicle to be raised off of the ground. To prevent possible injury to the servicing technician and/or bystanders, insure the vehicle is properly secured.

1. With the bypass valve open, (see Drive Wheel Release in the Operation section) and the engine running, slowly move the directional control in both forward and reverse directions (5 to 6 times). As air is purged from the unit, the oil level in the reservoir will drop.
2. With the bypass valve closed and the engine running, slowly move the directional control in both forward and reverse directions (5 to 6 times). Check the oil level, and add oil as required after stopping engine.
3. It may be necessary to repeat steps 1 and 2 until all the air is completely purged from the system. When the drive wheels rotate forward and reverse at normal speed and the reservoir oil remains at a constant level, purging is complete.

THREAD LOCKING ADHESIVES

Thread locking adhesives such as "Loctite 242" or "Fel-Pro, Pro-lock nut type" are used on the following fasteners:

1. Pump sheave setscrews.
2. Clutch retaining bolt in end of engine crankshaft.

COPPER-BASED ANTI-SEIZE

Copper-based anti-seize can be used in the following locations:

1. On threads of Blade Bolts. See **Check Mower Blades** section.
2. Between engine crankshaft, pump drive sheave, and clutch.

DIELECTRIC GREASE

Dielectric grease can be used on all blade type electrical connections to prevent corrosion and loss of contact.

CASTER PIVOT BEARINGS PRE-LOAD AND LUBRICATION

Service Interval: Once aYear

Tighten the nut until it is snug then back it off 1/8-1/4 turn. This will set the preload on the bearing. You should feel a slight drag as you rotate the caster fork clockwise and counterclockwise

1. Remove the protective cap from the top.
2. Pump grease into the fitting until grease is seen coming up through the bearing. Do not over fill. Do not fill the housing.
3. Reinstall the protective cap and tap into place

CHECK V-BELTS

Service Interval: Every 100 Hours

Deck Belt Removal:

1. Stop engine
2. Lower deck to lowest position
3. Remove belt shields
4. Place ratchet strap hook on the bolt of the deck idler arm (Loc A in Figure) and in hole in the RH lower strap (Loc B in Figure)
5. Tighten ratchet strap to rotate idler arm and relieve belt tension.
6. Remove deck belt

Deck Belt Installation

1. Perform steps 1-5 of Deck Belt Removal
2. Route belt onto deck sheaves and idlers. Refer to routing decal located on cutting deck
3. Roll belt onto clutch sheave

4. Loosen ratchet strap to return idler tension to belt
5. Verify belt is routed properly and is seated in all sheaves and idlers
6. Remove ratchet strap
7. Replace belt shields

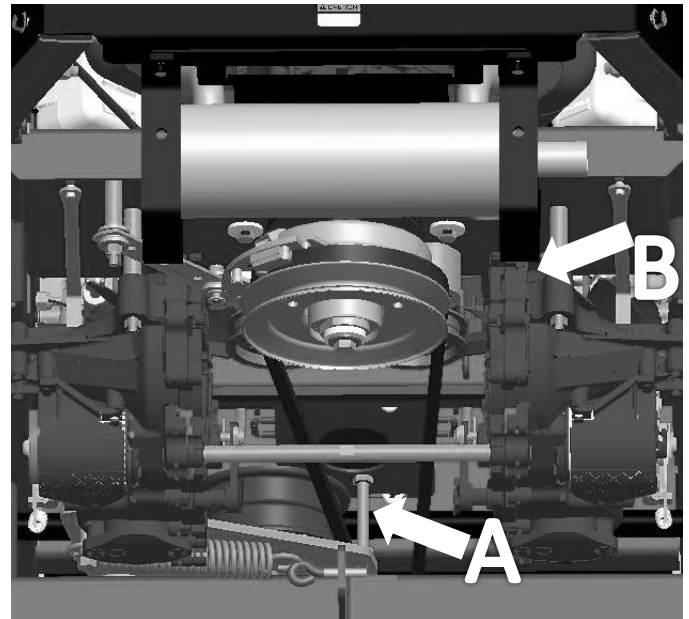

Pump Belt Removal:

1. Remove deck belt (see Deck Belt Removal)
2. Use pry bar through seat latch hole to apply pressure to Idler Arm to move belt.
3. Remove belt from engine and hydro sheaves.

Pump Belt Installation

1. From the rear of the machine, seat the belt into engine sheave
2. Pass forward edge of belt up between the cross shaft and clutch.
3. Route belt around hydro sheaves and stationary idler.
4. Use pry bar to apply pressure to idler arm, by inserting through seat latch bracket (Loc A in figure) and apply pressure to forward side of idler arm (Loc B in figure)
5. Re-install or re-tighten clutch anchor.
6. Reconnect jumper harness to clutch.
7. Re-install deck belt (see Deck Belt Installation)

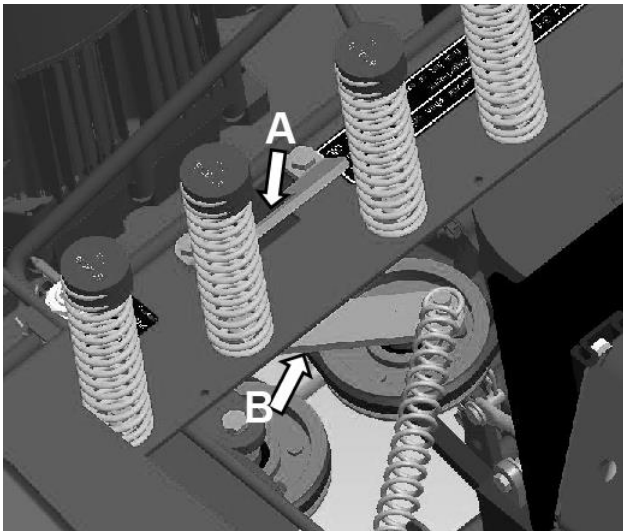

ADJUSTMENTS

Note: Disengage PTO, shut off engine, wait for all moving parts to stop, engage parking brake, and remove key before servicing, cleaning, or making any adjustments to the unit.



CAUTION

Raising the mower for service or maintenance relying solely on mechanical or hydraulic jacks could be dangerous. The mechanical or hydraulic jacks may not be enough support or may malfunction allowing the unit to fall, which could cause injury.

Do Not rely solely on mechanical or hydraulic jacks for support. Use adequate jack stands or equivalent support.

DECK LEVELING

Note: Small adjustments can be accomplished by increasing the tire pressure in the tire on the low side.

1. Park the machine on a level surface and disengage the blade control switch.
2. Stop engine, wait for all moving parts to stop, and remove key. Engage parking brake.
3. Check the air pressure in the drive tires. If needed, adjust to the recommended inflation; refer to **Checking the Tire Pressure** in the Drive System Maintenance section.
4. Set the height of cut to the desired position.
5. Raise the discharge deflector.
6. Carefully rotate the blades front to rear. Measure from the tip of the front blade to the level surface.

NOTE: In most conditions, the back tips should be adjusted 1/4 inch (6.4 mm) higher than the fronts.

7. Fine tune the front deck lift assembly by loosening adjuster jam nut, then slide bolt up or down in slot until blade is at the correct height.
8. Fine tune rear adjusters same as front detailed in #7.
9. Re-measure until all four sides are the correct height. Tighten all the nuts on the deck lift arm assemblies.
10. Lower discharge deflector.

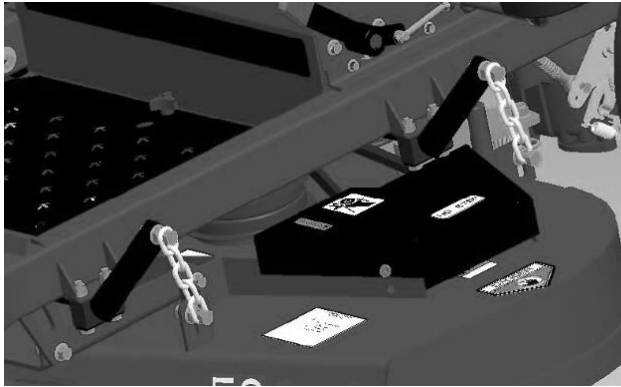

11. Re-tighten front and rear height-of-cut plate mounting bolts.
Important: Torque the front and rear height-of-cut plate mounting bolts to 27-33 ft-lb (37-45 N-m).
12. Repeat steps 6 through 10.
13. To achieve a cutting height greater than 4.75" you can remove additional blade spacers from the blade spindle assembly.

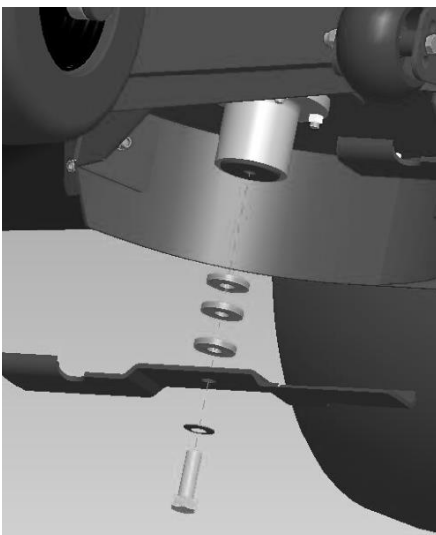

PUMP DRIVE BELT TENSION

Self-tensioning – no adjustment necessary.

MOWER DECK DRIVE BELT TENSION

Adjust deck tension idler by loosening or tightening eyebolt for more or less tension in the Mower Deck Drive Belt Tension area.

PARK BRAKE ADJUSTMENT

Check to make sure brake is adjusted properly. This procedure must be followed after the first 100 hours or when a brake component has been removed or replaced.

1. Drive the machine onto a level surface.
2. Disengage the blade control switch (PTO), move the motion control levers to the neutral locked position and set the parking brake.
3. Stop the engine, wait for all moving parts to stop and remove the key.
4. Raise the back of the machine up and support the machine with jack stands.



CAUTION

Raising the mower for service or maintenance relying solely on mechanical or hydraulic jacks could be dangerous. The mechanical or hydraulic jacks may not be enough support or may malfunction allowing the unit to fall, which could cause injury.

Do Not rely solely on mechanical or hydraulic jacks for support. Use adequate jack stands or equivalent support.

5. Lift park brake lever and hold in engaged position.
6. Tighten brake spring nut on RH link assembly until the swivel separates from retainer. Use a feeler gage to detect when this gap occurs.
7. Repeat step 6 for the LH side.

8. Disengage and re-engage park brake.
9. Repeat steps 6 and 7.
10. Remove jack stands.

MOTION CONTROL LINKAGE ADJUSTMENT

Located on either side of the fuel tank, below the seat are the pump control linkages. Rotating the pump linkage with a 1/2 inch wrench allows fine tuning adjustments so that the machine does not move in neutral. Any adjustments should be made for neutral positioning only.



WARNING

Engine must be running and drive wheels must be turning so adjustments can be performed. Contact with moving parts or hot surfaces may cause personal injury.

Keep fingers, hands, and clothing clear of rotating components and hot surfaces.

1. Prior to starting the engine, push the deck lift pedal and remove the height of cut pin. Lower deck to the ground.
2. Raise the rear of machine up and support with jack stands (or equivalent support) just high enough to allow drive wheels to turn freely.
3. Remove the electrical connection from the seat safety switch, located under the bottom cushion of the seat. The switch is a part of the seat assembly.
4. **Temporarily** install a jumper wire across the terminals in the connector of the main wiring harness.
5. Start engine. **Brake must be engaged and motion control levers out to start engine. Operator does not have to be in the seat because of the jumper wire being used.** Run engine at full throttle and release brake.
6. Run the unit at least 5 minutes with the drive levers at full forward speed to bring hydraulic oil up to operating temperature.

Note: The motion control lever needs to be in neutral while making any necessary adjustments.

7. Bring the motion control levers into the neutral position. Adjust pump control rod lengths by rotating the double nuts on the rod in the appropriate direction until the wheels slightly creep in reverse. See figure below. Move the motion control levers to the reverse position and while applying slight pressure to the lever allow the RTN springs to bring the levers back to neutral. The wheels must stop turning or slightly creep in reverse.

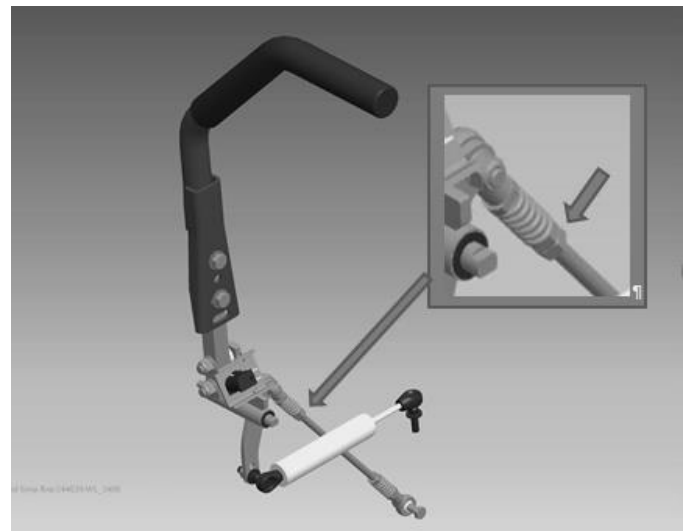

8. Shut off unit. Remove jumper wire from wire harness and plug connector into seat switch.
9. Remove the jack stands
10. Raise the deck and re-install the height of cut pin.
11. Check that the machine does not creep in neutral with the park brakes disengaged.

NEUTRAL ADJUSTMENT

If the hydro RTN requires adjustment, please refer to the appropriate Hydro Gear service manual for adjustment procedure.

MOTION CONTROL DAMPER ADJUSTMENT

Two positions are provided for installing the forward damper stud to the motion control assembly. The upper hole provides less resistance, the lower provides more.

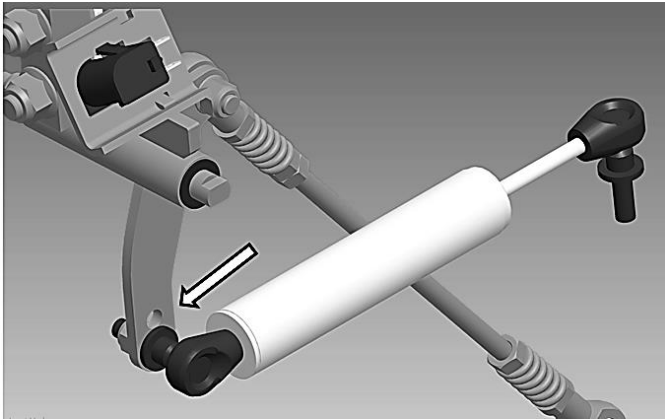

MOTION CONTROL NEUTRAL LOCK PIVOT ADJUSTMENT

The flanged nut can be adjusted to obtain a more desired motion control lever resistance

Tighten or loosen the lower flanged nut to the desired feel.

For more resistance, tighten the flanged nut.

For less resistance, loosen the flanged nut.

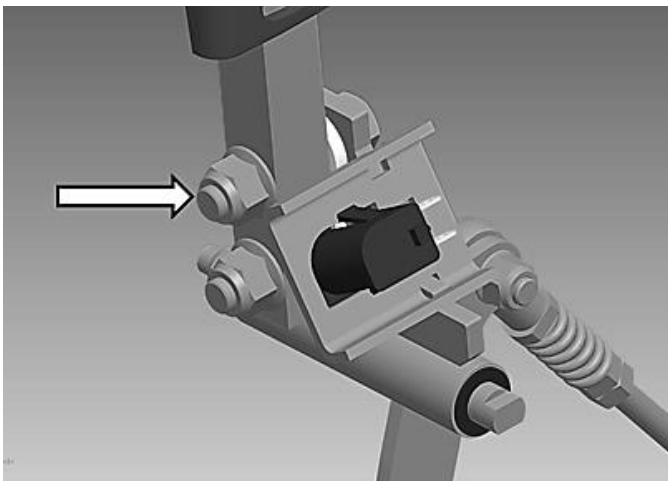

MOTION CONTROL HANDLE ADJUSTMENT

Adjusting the height:

The motion control levers can be adjusted higher or lower for maximum operator comfort.

1. Remove the two bolts holding the control lever to the control arm shaft (A)
2. Move the control lever to the next set of holes (B). Secure the lever with the two bolts.
3. Repeat the adjustment for the opposite control lever.

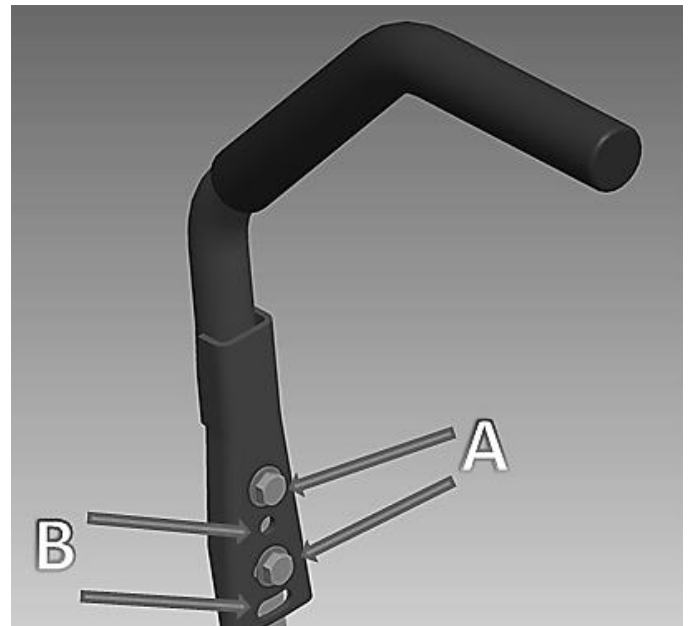

Adjusting the Tilt

The motion control levers can be tilted fore or aft for maximum operator comfort.

1. Loosen the upper bolt holding the control lever to the control arm shaft.
2. Loosen the lower bolt just enough to pivot the control lever fore or aft. Tighten both bolts to secure the control in the new position.
3. Repeat the adjustment for the opposite control lever.

CLEANING

Service Interval: Before each use or daily
(May be required more often in dry or dirty conditions.)



CAUTION

Excessive debris around engine cooling air intake and exhaust system area can cause engine exhaust area and hydraulic system to overheat which can create a fire hazard.

CLEAN ALL DEBRIS FROM ENGINE AND EXHAUST SYSTEM AREA.

1. Stop engine, wait for all moving parts to stop, and remove key. Engage parking brake.
2. Clean all debris from rotating engine air intake screen around engine shrouding, and exhaust system area.
3. Wipe up any excessive grease or oil around the engine and exhaust system area.

CLEAN DUST AND DIRT FROM CYLINDER HEAD FINS.

Service Interval: Every 100 hours

1. Stop engine, wait for all moving parts to stop, and remove key. Engage parking brake.
2. Remove cooling shrouds from engine and clean cooling fins. Also clean dust, dirt and oil from external surfaces of engine which can cause improper cooling.
3. Make sure cooling shrouds are properly reinstalled. Operating the engine without cooling shrouds will cause engine damage due to overheating.

CLEAN DEBRIS FROM MACHINE

Service Interval: Before each use or daily

1. Stop engine, wait for all moving parts to stop, and remove key. Engage parking brake.
2. Clean off any oil, debris, or grass build-up on the machine and cutting deck, especially under deck belt shields, around the fuel tank, around engine and exhaust area.

CLEAN GRASS BUILD-UP UNDER DECK

Service Interval: Before each use or daily

1. Stop engine, wait for all moving parts to stop, and remove key. Engage parking brake.
2. Raise deck to the transport (maximum cutting height) position. Lift the front of unit and support unit using jack stands or equivalent support.



CAUTION

Raising the mower for service or maintenance relying solely on mechanical or hydraulic jacks could be dangerous. The mechanical or hydraulic jacks may not be enough support or may malfunction allowing the unit to fall, which could cause injury.

Do not rely solely on mechanical or hydraulic jacks for support. Use adequate jack stands or equivalent support.

3. Clean out any grass build-up from underside of deck and in discharge deflector.

TROUBLESHOOTING

IMPORTANT: It is essential that all operator safety mechanisms be connected and in proper operating condition prior to mower use.

When a problem occurs, do not overlook the simple causes. For example, starting problems could be caused by an empty fuel tank.

The following table lists some of the common causes of trouble. Do not attempt to service or replace major items or any items that call for special timing of adjustments procedures. Have this work done by your Service Dealer.

PROBLEM	POSSIBLE CAUSE
Engine will not start	<ul style="list-style-type: none"> • Contamination in the carburetor or fuel line. • Fuel supply is closed or the tap for the fuel tank is in the wrong position. • Clogged fuel filter or fuel line. • Faulty ignition system.
Starter does not turn the engine over.	<ul style="list-style-type: none"> • Blade switch is engaged. • Steering controls are not locked in the neutral position • Parking brake is not activated • Dead battery. • Poor contacts on the battery terminal cable connections. • Fuse blown. • Ignition system faulty. • Fault in the starter safety circuit See <i>Safety Interlock System</i> in the Maintenance section.
Engine runs rough.	<ul style="list-style-type: none"> • Faulty carburetor. • Choke control is pulled out with warm engine. • Clogged fuel filter or jet. • Clogged ventilation valve on the fuel cap. • Fuel tank nearly empty. • Fouled spark plug. • Spark plug is loose. • Rich fuel mixture or fuel-air mixture (gasoline). • Wrong fuel type (gasoline). • Water in the fuel (gasoline). • Clogged air filter

TROUBLESHOOTING

PROBLEM	POSSIBLE CAUSE
Engine seems weak	<ul style="list-style-type: none"> • Clogged air filter • Fouled spark plugs. • Carburetor incorrectly adjusted
Machine vibrates.	<ul style="list-style-type: none"> • Blades are loose. • Blades are incorrectly balanced. • Engine is loose.
Engine overheats.	<ul style="list-style-type: none"> • Clogged air intake or cooling fins. • Engine overloaded. • Poor ventilation around engine. • Defective engine speed regulator. • Too little or no oil in the engine. • Fouled spark plug.
Batter not charging.	<ul style="list-style-type: none"> • Poor contact with battery terminal cable connectors. • Charging lead is disconnected.
Machine moves slowly, unevenly, or not at all.	<ul style="list-style-type: none"> • Parking brake on. • Bypass valve on pump open. • Drive belt for the transmission is slack or has come off. • Air in hydraulic system.
Mower deck not engaging.	<ul style="list-style-type: none"> • Drive belt for the mower deck has come loose. • Electric connection to clutch has loosened. • Blade switch is faulty or has come loose from the cable contact. • Fuse has blown.
Hydraulic drive leaks oil.	<ul style="list-style-type: none"> • Damaged seals, housing, or gaskets. • Air trapped in hydraulic system.
Uneven mowing results.	<ul style="list-style-type: none"> • Unequal tire pressure on the left and right sides. • Bent blades. • Suspension for the mower deck is uneven. • Blades are dull. • Driving speed too high. • Grass is too long. • Grass collected under the mower deck.

STORAGE

WINTER STORAGE

The machine should be readied for storage at the end of the mowing season, or if it will not be in use for more than 30 days.

Fuel allowed to stand for long periods of time (30 days or more) can leave sticky residues that can plug the carburetor and disrupt engine function.

Fuel stabilizers are an acceptable option as regards to the sticky residues that can occur during storage.

Add stabilizer to the fuel in the tank or in the storage container. Always use the mixing ratios specified by the manufacturer of the stabilizer. Run the engine for at least 10 minutes after adding the stabilizer so that it reaches the carburetor. Do not empty the fuel tank and the carburetor if a stabilizer has been added.

To ready the machine for storage, follow these steps:

1. Thoroughly clean the machine, especially under the mower deck. Touch up damage to the paint and spray a thin layer of oil on the underside of the mower deck to avoid corrosion.
2. Inspect the machine for worn or damaged parts and tighten any nuts or screws that may have become loose.
3. Change the engine oil; dispose of properly.
4. Empty the fuel tanks or add a fuel stabilizer. Start the engine and allow it to run until the carburetor is drained of fuel or the stabilizer has reached the carburetor.
5. Remove the spark plug and pour about a tablespoon of engine oil into the cylinder. Turn over the engine so that the oil is evenly distributed and then refit the spark plug.
6. Lubricate all grease zerks, joints, and axles.
7. Remove the battery. Clean, charge, and store the battery in a cool place, but protect it from direct cold.
8. Store the machine in a clean, dry place and cover it for extra protection.

DIAMONDBACK WIRING HARNESS

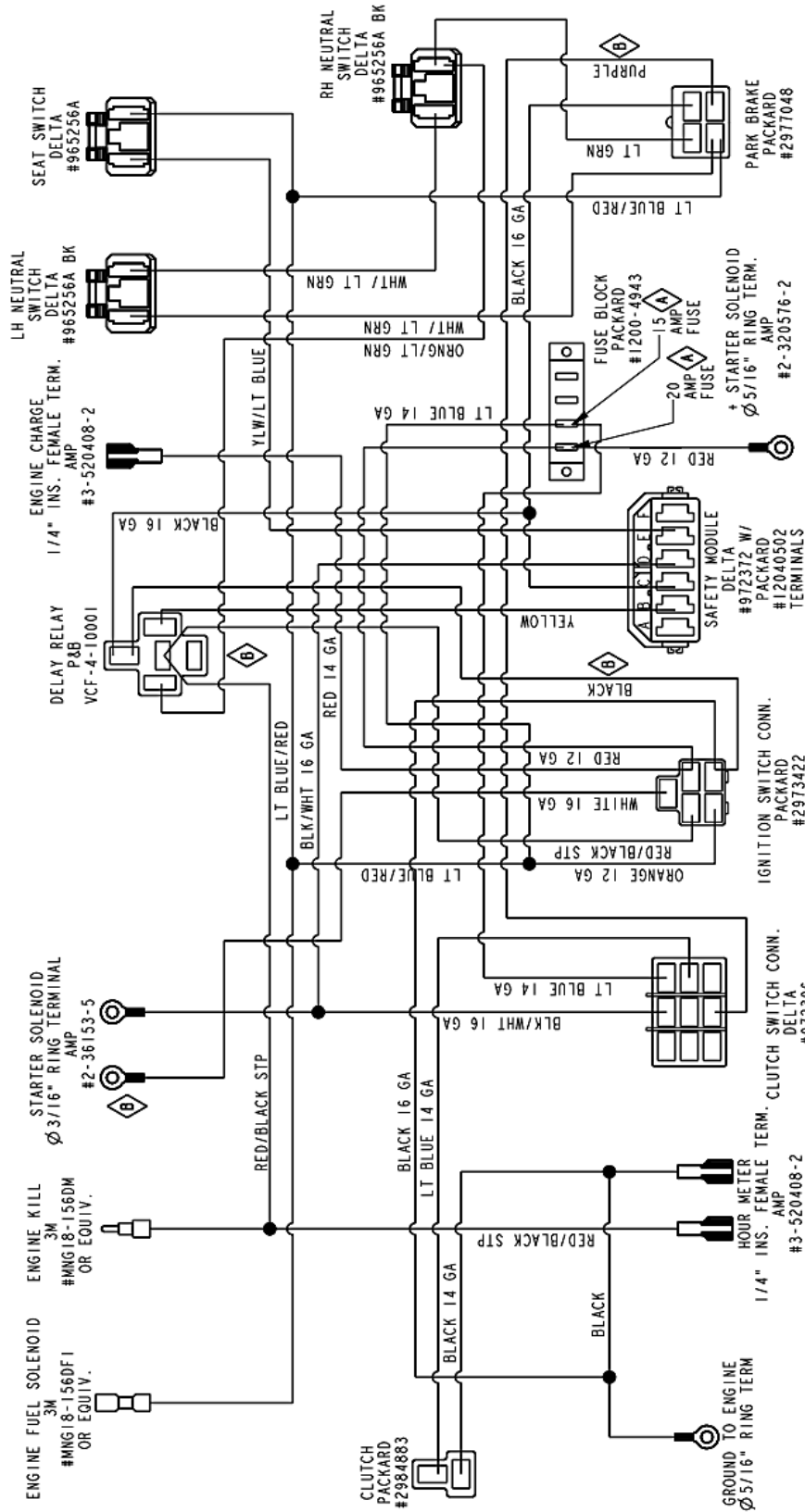

- NOTES:
1. ALL WIRE IS 18 GA. UNLESS NOTED OTHERWISE
 2. ALL WIRE, TERMINALS AND CONSTRUCTION ARE TO BE PER NMMA/ABYC ENGINEERING SPECIFICATIONS
 3. ALL LIKE COLORED WIRES MUST BE ELECTRONICALLY CONNECTED UNLESS CIRCUIT CODING SHOWS OTHERWISE.
 4. ALL TERMINALS ARE TO BE SIZED TO THE GAUGE OF WIRE THEY ARE BEING INSTALLED ON.
 5. ALL HOUSINGS AND MOLDED PLUGS THAT SHOW PIN POSITION ARE FROM REAR (WIRE SIDE) VIEW.

DIAMONDBACK XL WIRING HARNESS

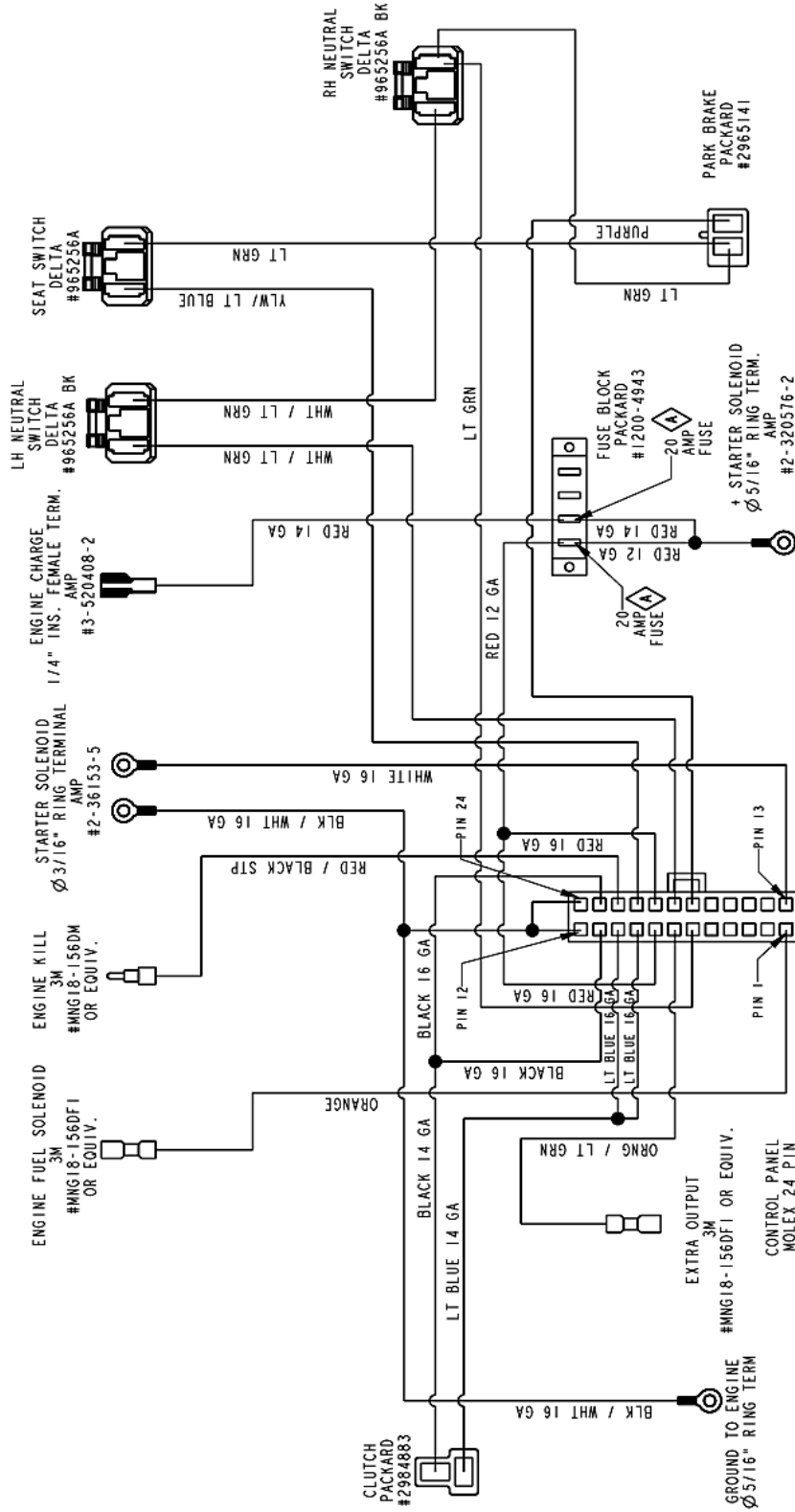

- NOTES:
1. ALL WIRE IS 18 GA. UNLESS NOTED OTHERWISE
 2. ALL WIRE TERMINALS AND CONSTRUCTION ARE TO BE PER NMMA/ABYC ENGINEERING SPECIFICATIONS
 3. ALL LINE COLORED WIRES MUST BE ELECTRONICALLY CONNECTED UNLESS CIRCUIT CODING SHOWS OTHERWISE.
 4. ALL TERMINALS ARE TO BE SIZED TO THE GAUGE OF WIRE THEY ARE BEING INSTALLED ON.
 5. ALL HOUSINGS AND MOLDED PLUGS THAT SHOW PIN POSITION ARE FROM REAR (WIRE SIDE) VIEW.

DIAMONDBACK MAXX WIRING HARNESS

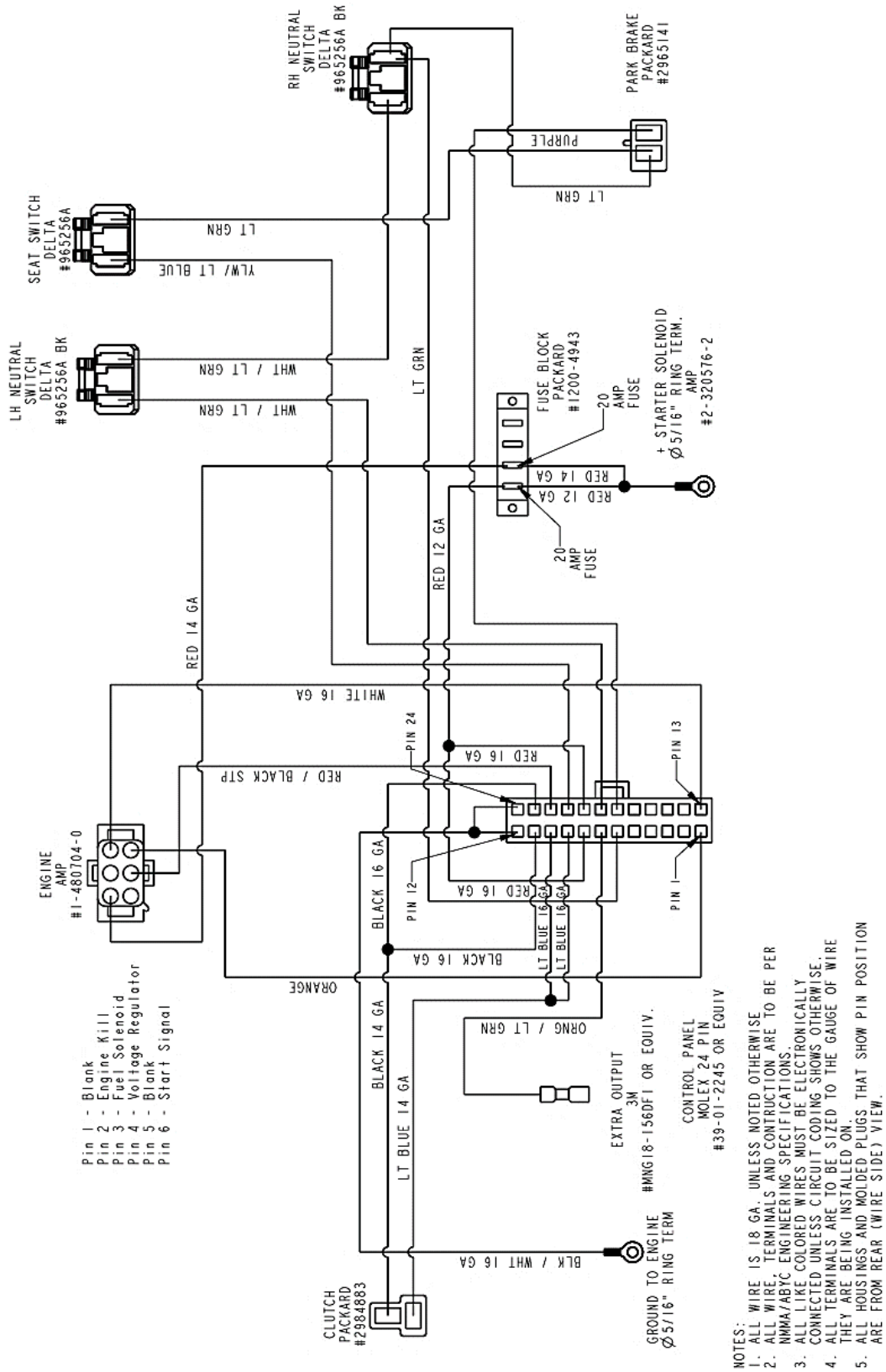

- NOTES:
1. ALL WIRE IS 18 GA. UNLESS NOTED OTHERWISE
 2. ALL WIRE, TERMINALS AND CONSTRUCTION ARE TO BE PER NMMA/ABYC ENGINEERING SPECIFICATIONS.
 3. ALL LIKE COLORED WIRES MUST BE ELECTRONICALLY CONNECTED UNLESS CIRCUIT CODING SHOWS OTHERWISE.
 4. ALL TERMINALS ARE TO BE SIZED TO THE GAUGE OF WIRE THEY ARE BEING INSTALLED ON.
 5. ALL HOUSINGS AND MOLDED PLUGS THAT SHOW PIN POSITION ARE FROM REAR (WIRE SIDE) VIEW.

DIAMONDBACK XE WIRING HARNESS

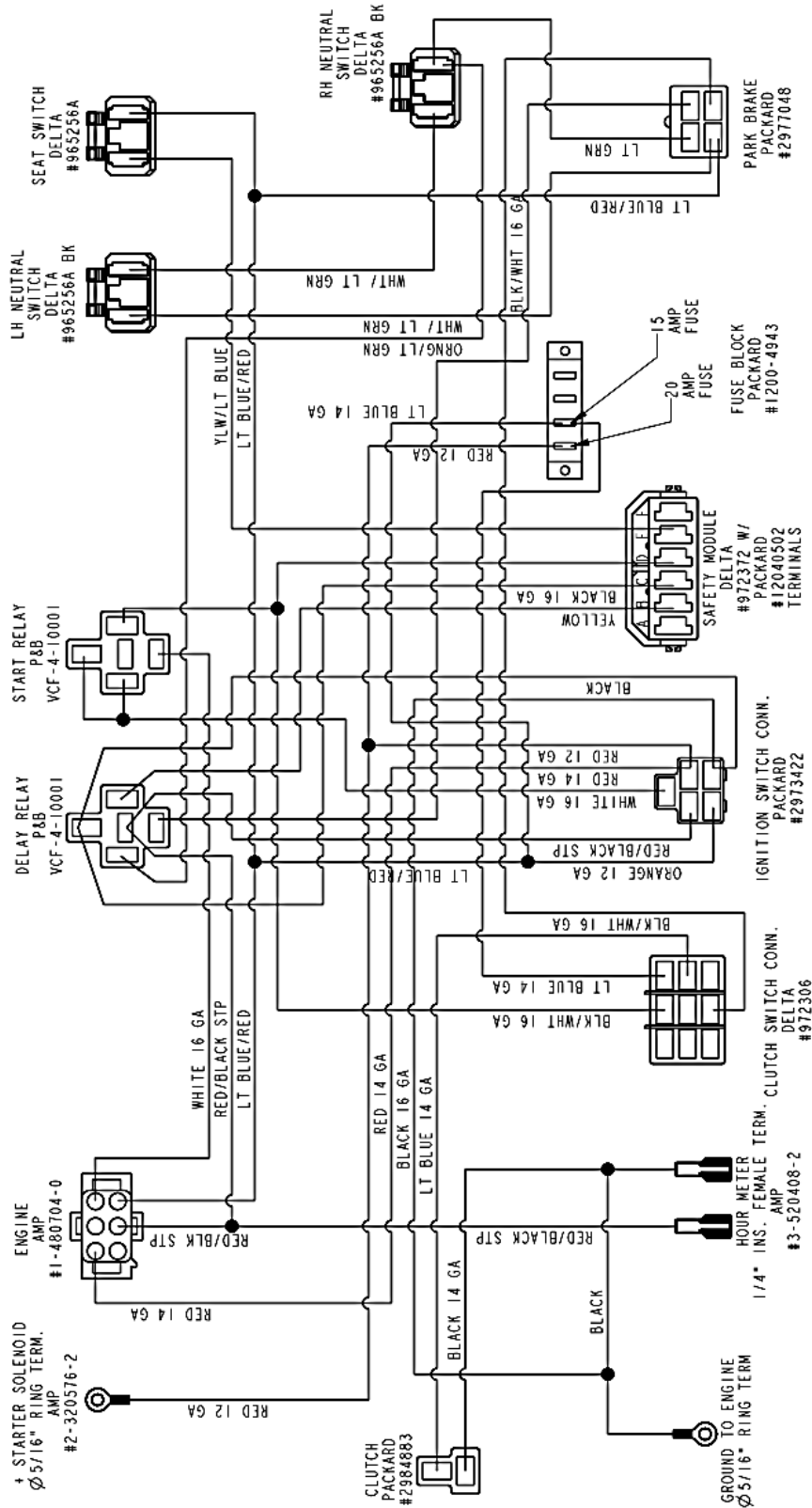

- NOTES:
1. ALL WIRE IS 18 GA. UNLESS NOTED OTHERWISE.
 2. ALL WIRE, TERMINALS AND CONSTRUCTION ARE TO BE PER NMMA/ABYC ENGINEERING SPECIFICATIONS.
 3. ALL LIKE COLORED WIRES MUST BE ELECTRONICALLY CONNECTED UNLESS CIRCUIT CODING SHOWS OTHERWISE.
 4. ALL TERMINALS ARE TO BE SIZED TO THE GAUGE OF WIRE THEY ARE BEING INSTALLED ON.
 5. ALL HOUSINGS AND MOLDED PLUGS THAT SHOW PIN POSITION ARE FROM REAR (WIRE SIDE) VIEW.

EVAPORATIVE EMISSION CONTROL WARRANTY STATEMENT

CALIFORNIA EVAPORATIVE EMISSION CONTROL WARRANTY STATEMENT

YOUR WARRANTY RIGHTS AND OBLIGATIONS

The California Air Resources Board and Worldlawn Power Equipment is pleased to explain the evaporative emission control system's warranty on the 2017 model year lawn mower. In California, new equipment that use small off-road engines must be designed, built, and equipped to meet the State's stringent anti-smog standards. Worldlawn Power Equipment must warrant the evaporative emission control system on your lawn mower for the period listed below provided there has been no abuse, neglect or improper maintenance of your equipment.

Your evaporative emission control system may include parts such as: fuel tanks, fuel lines, fuel caps, valves, canisters, vapor hoses, clamps, connectors, and other associated components. **For engines less than or equal to 80 cc, only the fuel tank is subject to the evaporative emission control warranty requirements of this section.**

MANUFACTURER'S WARRANTY COVERAGE:

This evaporative emission control system is warranted for two years. If any evaporative emission-related part on your equipment is defective, the part will be repaired or replaced by Worldlawn Power Equipment.

OWNER'S WARRANTY RESPONSIBILITIES:

- As the lawn mower owner, you are responsible for performance of the required maintenance listed in your owner's manual. Worldlawn Power Equipment recommends that you retain all receipts covering maintenance on your lawn mower, but Worldlawn Power Equipment cannot deny warranty solely for the lack of receipts.
- As the lawn mower owner, you should however be aware that Worldlawn Power Equipment may deny you warranty coverage if your fuel tank has failed due to abuse, neglect, or improper maintenance or unapproved modifications.
- You are responsible for presenting your lawn mower to a Worldlawn Power Equipment distribution center or service center as soon as the problem exists. The warranty repairs should be completed in a reasonable amount of time, not to exceed 30 days. If you have a question regarding your warranty coverage, you should contact Worldlawn Power Equipment service at (402) 228-4255.

DEFECTS WARRANTY REQUIREMENTS:

(a) The warranty period begins on the date the engine or equipment is delivered to an ultimate purchaser. .

(b) General Evaporative Emissions Warranty Coverage. The fuel tank must be warranted to the ultimate purchaser and any subsequent owner that the evaporative emission control system when installed was:

- (1) Designed, built, and equipped so as to conform with all applicable regulations; and
 - (2) Free from defects in materials and workmanship that causes the failure of a warranted part for a period of two years.
- (c) The warranty on evaporative emissions-related parts will be interpreted as follows:

(1) Any warranted part that is not scheduled for replacement as required maintenance in the written instructions must be warranted for the warranty period defined in subsection (b)-(2). If any such part fails during the period of warranty coverage, it must be repaired or replaced by Worldlawn Power Equipment. Any such part repaired or replaced under the warranty must be warranted for a time not less than the remaining warranty period.

(2) Any warranted part that is scheduled only for regular inspection in the written instructions must be warranted for the warranty period defined in subsection (b)-(2). A statement in such written instructions to the effect of "repair or replace as necessary" will not reduce the period of warranty coverage. Any such part repaired or replaced under warranty must be warranted for a time not less than the remaining warranty period.

(3) Any warranted part that is scheduled for replacement as required maintenance in the written instructions must be warranted for the period of time prior to the first scheduled replacement point for that part. If the part fails prior to the first scheduled replacement, the part must be repaired or replaced by Worldlawn Power Equipment. Any such part repaired or replaced under warranty must be warranted for a time not less than the remainder of the period prior to the first scheduled replacement point for the part.

(4) Repair or replacement of any warranted part under the warranty provisions of this article' must be performed at no charge to the owner at a warranty station.

(5) Notwithstanding the provisions of subsection (4) above, warranty services or repairs must be provided at distribution centers that are franchised to service the subject engines or equipment.

(6) The owner must not be charged for diagnostic labor that leads to the determination that a warranted part is in fact defective, provided that such diagnostic work is performed at a warranty station.

(7) Throughout the evaporative emission control system's warranty period set out in subsection (b)(2), Worldlawn Power Equipment must maintain a supply of warranted parts sufficient to meet the expected demand for such parts.

(8) Manufacturer approved replacement parts must be used in the performance of any warranty maintenance or repairs and must be provided without charge to the owner. Such use will not reduce the warranty obligations of the manufacturer issuing the warranty.

(9) The use of any add-on or modified parts will be grounds for disallowing a warranty claim made in accordance with this article. Worldlawn Power Equipment will not be liable under this Article to warrant failures of warranted parts caused by the use of an add-on or modified part.

(10) Worldlawn Power Equipment shall provide any documents that describe the warranty procedures or policies within five working days of request by the Air Resources Board.

EMISSION WARRANTY PARTS LIST:

1) Fuel Tank, 2) Fuel line, 3) Fuel cap, 4) remote vent, 5) Carbon canister

Written instructions for the maintenance and use of the evaporative emissions control system by the owner shall be furnished with each new engine or equipment.



LIMITED WARRANTY

GENERAL PROVISIONS The product warranty described in this document is provided by Worldlawn Power Equipment, Inc., (“Worldlawn”) and is a limited warranty. Worldlawn will warrant on the terms and conditions herein and applies to the original purchasers of new product from Worldlawn Power Equipment or an authorized Worldlawn dealer/retailer. Worldlawn’s sole responsibility with any claim made under this warranty is limited to repair or replacement of any part in the excise of our reasonable discretion, to be defective in materials or workmanship from the original date of purchase (see warranty period below for details) and no claim of breach of warranty shall be cause for rescission, cancellation, or voiding the contract of sale of the mower.

EXCLUSIONS, CONDITIONS, and EXCEPTIONS This limited warranty extends only to those mowers purchased for private residential and commercial use. A mower purchase for any other reason, for example as a rental unit, shall have a (90) ninety day limited warranty under the same terms and conditions as set forth herein. Any work done on or to the mower by anyone other than an authorized Worldlawn dealer/retailer, including the original purchaser, voids all provisions of the warranty except those provisions which limit Worldlawn’s liability (as set forth below). This limited warranty specifically excludes normal wear items, included but not limited to belts, blades, and tires. This limited warranty does not extend to any mower or part thereof which has been misused, neglected, damaged, abused, altered, not properly serviced or maintained, or which has been operated in any way contrary to the operating instructions as specified in the owners/operator manual. This limited warranty does not extend to any repair or replacement made necessary by the effects of the weather, environment, transportation, or accidents. The warranty herein is in lieu of other warranties, express or implied, including , without limitation, any implied warranty of merchantability or fitness for a particular use, and is in lieu of any and all other obligations or liability on Worldlawn’s part. Under any and all circumstances, Worldlawn’s total liability to the owner for any and all claims, losses or damages, including loss of profits, arising out of any cause whatsoever, whether based in contract, negligence or other tort, strict liability breach of warranty or otherwise, shall in no event exceed the purchase price of the mower. In no event shall Worldlawn be responsible for special, incidental, consequential or exemplary damages. This limited warranty specifically excludes parts covered under another manufacturer’s warranty.

OBTAINING WARRANTY SERVICE Upon purchase the authorized dealer/retailer must submit the completed warranty registration documentation to Worldlawn to validate the warranty. The owner should retain, and upon request provide, the original bill of sale or proof of purchase. The mower must be returned to an authorized Worldlawn dealer/retailer within the warranty period. The cost of delivering the mower to the authorized dealer and the return delivery shall be the responsibility of the owner. Only authorized Worldlawn dealers/retailer are allowed to perform warranty service.

WARRANTY PERIOD 3 YEARS Models represented for this warranty are as follows.

WYDB52FR691V32, WYDB52FR691V32CA, WYDB52FS691V34, WYDB52FS691V34CA, WYDB52CT810V34, WYDB52CT810V34CA

COMPONENT or SYSTEM	WARRANTY SERVICE THROUGH	WARRANTY PROVIDED BY	PERIOD
Engines	Engine Manufacture	Engine Manufacture	3 Years
Electric PTO Clutches	Worldlawn	Clutch Manufacture	2 Years
Hydraulic ZT-3200	Worldlawn	Hydraulic Manufacture	1 Year Commercial 2 Years Residential
Hydraulic ZT-3400	Worldlawn	Hydraulic Manufacture	2 Years Commercial and Residential
Batteries	Worldlawn	Worldlawn	1 Year
Mower Cutting Deck Shells	Worldlawn	Worldlawn Part & Labor	0-5 Years
Mower Cutting Deck Shells	Worldlawn	Worldlawn Part Only	5-10 Years



WORLDLAWN[®]